

GUIDED EJECTION SUPPORT PILLARS

INCH

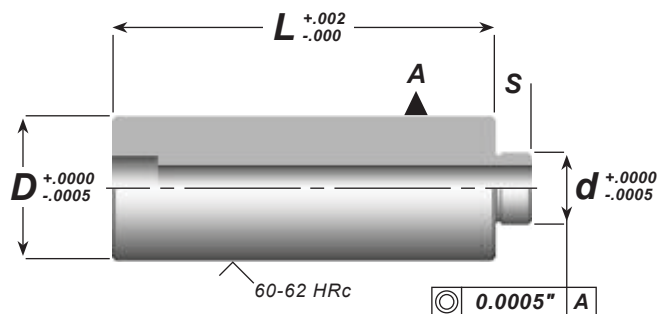

D	d	S	CATALOG NUMBER						
			L=2-1/2"	L=3"	L=3-1/2"	L=4"	L=4-1/2"	L=5"	L=6"
3/4	0.468	0.281	SSP07525	SSP07530	SSP07535	SSP07540			
1"	0.500	0.312	SSP10025	SSP10030	SSP10035	SSP10040	SSP10045		
1-1/4	0.687	0.312	SSP12525	SSP12530	SSP12535	SSP12540	SSP12545	SSP12550	SSP12560
1-1/2	0.750	0.375	SSP15025	SSP15030	SSP15035	SSP15040	SSP15045	SSP15050	SSP15060
2"	0.750	0.375	SSP20025	SSP20030	SSP20035	SSP20040	SSP20045	SSP20050	SSP20060

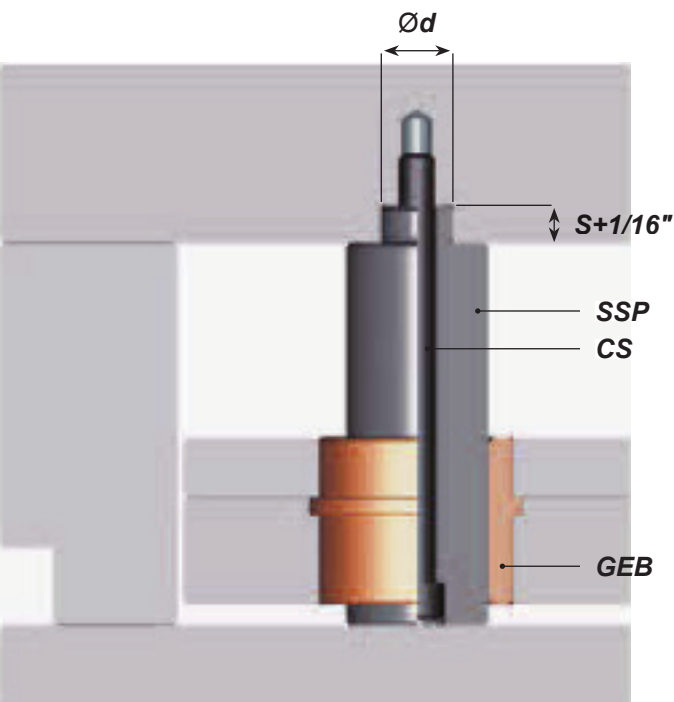

- ▶ Available in standard lengths.
- ▶ Case hardened.
- ▶ For use with any standard guided ejector bushing.
- ▶ Bottom clamp plate machining is not required.
- ▶ No press fit concerns.
- ▶ Ejector set machining is significantly reduced.

DESIGN INFORMATION			
D	Depth of reamed hole for 'd'	Tapped hole depth for capscrew	Capscrew (supplied)
3/4	0.343	0.468	1/4-20 x L+.250
1"	0.375	0.562	5/16-18 x L+.500
1-1/4	0.375	0.562	5/16-18 x L+.500
1-1/2	0.437	0.656	3/8-16 x L+.500
2"	0.437	0.656	3/8-16 x L+.500