















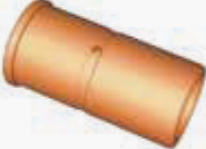

<p><b>p1 – p3</b> Leader Pins – Straight</p> 	<p><b>p4</b> Leader Pins – Shoulder</p> 	<p><b>p5</b> Guided Ejector Leader Pins</p> 
<p><b>p6</b> Shoulder Leader Pins &amp; Bushings – 1/2"</p> 	<p><b>NEW SIZES</b> <b>p7</b> Metric Leader Pins</p> 	<p><b>p8</b> Shoulder Bushings – Steel</p> 
<p><b>p9</b> Shoulder Bushings – Solid Bronze</p> 	<p><b>p10</b> Shoulder Bushings – Self-lubricating</p> 	<p><b>p11</b> Shoulder Bushings – Bronze-plated</p> 
<p><b>NEW</b> <b>p12</b> Shoulder Bushings</p> 	<p><b>p13</b> Straight Bushings</p>  <p>Steel      Solid Bronze</p>	<p><b>p14</b> Straight Bushings</p>  <p>Bronze-plated      Self-lubricating</p>
<p><b>p15</b> Guided Ejector Bushings</p>  <p>Steel      Solid Bronze</p>	<p><b>p16</b> Guided Ejector Bushings</p>  <p>Bronze-plated      Self-lubricating</p>	<p><b>p17</b> Ball-Guided Ejector Bushings</p> <p>Bolexp®</p> 
<p><b>p18</b> Guided Ejector Support Pillars – Inch</p> 	<p><b>p19</b> Guided Ejector Support Pillars – Metric</p> 	<p><b>p20</b> Standard Support Pillars – Tapped</p> 

# INDEX

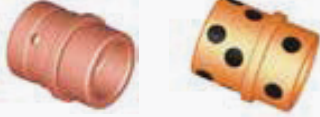
**p21**  
**Sprue Bushings**  
 (B- & A-Series)

**p22**  
**Sprue Bushings (U-Series)**

**p23**  
**Sprue Reamers**

**p24 – p25**  
**Locating Rings**

**p26**  
**Round Tapered Interlocks**

**p27**  
**Spacer Plates**

**p28**  
**Tapered Bar Locks**

**p29**  
**Side Locks**

**p30**  
**Top Locks**

**p31**  
**Guide Locks**

**p32**  
**E Side Locks**

**p33**  
**E Side Locks (Treated)**

**p34**  
**Gib Assemblies**

**p35 – p40**  
**Slide Retainers**

**p41 – p42**  
**Slide Latches**

















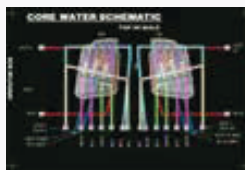

**p43**  
**Angle Pins**

Angle Pins (Standard)

Angle Pins (Raidused Head)

**p44**  
**Springs – Medium Duty**

**p45**  
**Springs – Medium Heavy Duty**

<p style="text-align: right;"><b>p46</b></p> <p style="text-align: center;"><b>Springs – Heavy Duty</b></p> 	<p style="text-align: right;"><b>p47</b></p> <p style="text-align: center;"><b>Air Poppets</b></p> 	<p style="text-align: left;"><b>NEW</b></p> <p style="text-align: right;"><b>p48</b></p> <p style="text-align: center;"><b>Sintered Vents</b></p> 
<p style="text-align: left;"><b>NEW SIZES</b></p> <p style="text-align: right;"><b>p49</b></p> <p style="text-align: center;"><b>E Series Date Stamps</b></p> 	<p style="text-align: right;"><b>p50</b></p> <p style="text-align: center;"><b>Dual Ring Date Stamps</b></p> 	<p style="text-align: right;"><b>p51</b></p> <p style="text-align: center;"><b>Date Stamps &amp; Inserts</b></p> 
<p style="text-align: right;"><b>p52</b></p> <p style="text-align: center;"><b>Date Stamps &amp; Inserts</b></p> 	<p style="text-align: right;"><b>p53</b></p> <p style="text-align: center;"><b>Recycle Inserts</b></p> 	<p style="text-align: left;"><b>ICS Laser Technologies</b></p> <p style="text-align: right;"><b>p54</b></p> <p style="text-align: center;"><b>Full Colour Mold Plaques</b></p> 
<p style="text-align: right;"><b>p55</b></p> <p style="text-align: center;"><b>RedEVault Mold Data Storage</b></p> 	<p style="text-align: right;"><b>p56 – p58</b></p> <p style="text-align: center;"><b>In-Mold Edge Gate Cutting</b></p> 	<p style="text-align: left;"><b>NEW</b></p> <p style="text-align: right;"><b>p59</b></p> <p style="text-align: center;"><b>Lifter Feet</b></p> 
<p style="text-align: left;"><b>NEW</b></p> <p style="text-align: right;"><b>p60</b></p> <p style="text-align: center;"><b>U Couplings T-Gibs</b></p> 	<p style="text-align: left;"><b>NEW</b></p> <p style="text-align: right;"><b>p61</b></p> <p style="text-align: center;"><b>CPLP-PLP Parting Line Pads</b></p> 	<p style="text-align: right;"><b>p62</b></p> <p style="text-align: center;"><b>Rhino Feet And Toes</b></p> 
<p style="text-align: right;"><b>p63 – p64</b></p> <p style="text-align: center;"><b>Runner Shut-Offs</b></p> 	<p style="text-align: right;"><b>p65</b></p> <p style="text-align: center;"><b>Sprue Adjuster</b></p> 	<p style="text-align: left;"><b>imold</b></p> <p style="text-align: right;"><b>p66 – p67</b></p> <p style="text-align: center;"><b>Cashew Gate Inserts (S1 Series)</b></p>  <p style="text-align: center;"><b>TGR</b>      <b>TGS</b></p>

**i-mold** p68 – p69  
**Cashew Gate Inserts**  
 (S2 Series)

TGR

TGS

p70 – p71

**Cashew Gate Inserts**  
 (Contourable)

TGC

p72 – p73

**Cashew Gate Inserts**  
 (Side Gate Contourable)

SGC

p72

**Retaining Bush** (for use with  
 Cashew Gate Inserts)

p74

**Cashew Gate Inserts**  
 - Miniflow (GTM)

p75

**Cashew Gate Inserts**  
 (GTE - 14mm)

p76

**Cashew Gate Inserts**  
 (GTR - 14mm)

p77

**Cashew Gate Inserts**  
 (GTE - 12mm)

p78

**Cashew Gate Inserts**  
 (GTR - 12mm)

p79

**Cashew Gate Inserts**  
 (GTE - 10mm)

p80

**Cashew Gate Inserts**  
 (GTR - 10mm)

p81 – p82

**Cashew Gate Inserts**  
 - Kontourflow (GTK)

EXAflow®

p83 – p84

**Cashew Gate Inserts**  
 - Maxiflow (GTK)

EXAflow®

p85

**Installation Data for**  
 Cashew Gate Inserts

EXAflow®

# LEADER PINS

STRAIGHT — 1<sup>1/2</sup> — 3"

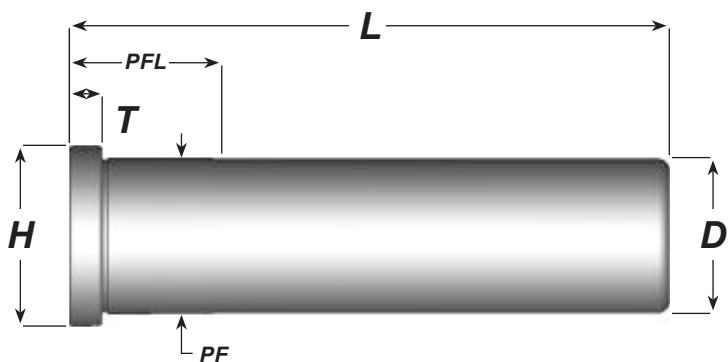

General Dimensions and Tolerances				
Nominal Diameter	D +.0000 -.0005	PF +.0005 -.0000	H +.000 -.010	T +.000 -.005
1-1/2	1.499	1.501	1.740	5/16
2"	1.999	2.001	2.240	5/16
2-1/2	2.499	2.501	2.740	5/16
3"	2.999	3.001	3.365	1/2

L	D=1-1/2"		D=2"		D=2-1/2"		D=3"		L
	PFL	Cat. No.	PFL	Cat. No.	PFL	Cat. No.	PFL	Cat. No.	
3-3/4	1-3/8	1402							3-3/4
4-1/4	1-3/8	1403							4-1/4
4-3/4	1-3/8	1404							4-3/4
5-1/4	1-3/8	1405							5-1/4
5-3/4	1-3/8	1406	1-7/8	1606	2-3/8	1806			5-3/4
6-1/4	1-3/8	1407							6-1/4
6-3/4	1-3/8	1408	1-7/8	1608					
7-1/4									7-1/4
7-3/4	1-7/8	1410	1-7/8	1610	2-3/8	1810			7-3/4
8-1/4									8-1/4
8-3/4	1-7/8	1412	1-7/8	1612	2-3/8	1812			8-3/4
9-1/4									9-1/4
9-3/4	1-7/8	1414	1-7/8	1614	2-3/8	1814			9-3/4
10-1/4									10-1/4
10-3/4	1-7/8	1416	1-7/8	1616	2-3/8	1816			10-3/4
11-1/4									11-1/4
11-3/4	1-7/8	1418	1-7/8	1618	2-3/8	1818			11-3/4
12-1/4									12-1/4
12-3/4	1-7/8	1420	1-7/8	1620	2-3/8	1820	2-7/8	3020	12-3/4
13-3/4	1-7/8	1422	1-7/8	1622	2-3/8	1822			13-3/4
14-3/4	1-7/8	1424	1-7/8	1624	2-3/8	1824	2-7/8	3024	14-3/4
15-3/4	1-7/8	1426	1-7/8	1626	2-3/8	1826			15-3/4
16-3/4			2-3/8	1628	2-3/8	1828	2-7/8	3028	15-3/4
18-3/4			2-3/8	1632	2-3/8	1832	2-7/8	3032	18-3/4
NEW 36	2-3/8	LP1-1/2x36	2-3/8	LP2x36	2-3/8	LP2-1/2x36	2-7/8	LP3x36	36



# LEADER PINS

STRAIGHT — 1<sup>1/2</sup> — 3"

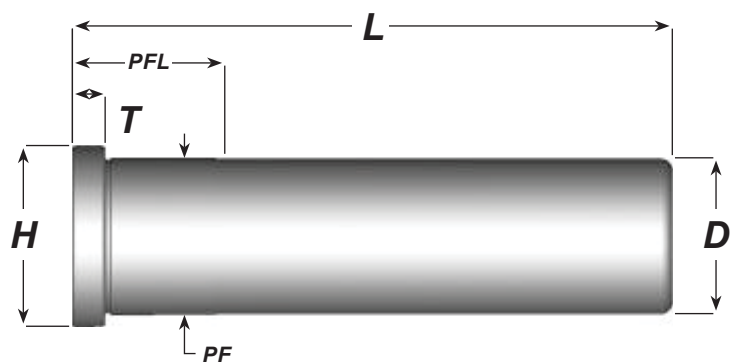

General Dimensions and Tolerances				
Nominal Diameter	D	PF	H	T
	+0.000 -0.0005	+0.0005 -0.0000	+0.000 -0.010	+0.000 -0.005
1-1/2	1.499	1.501	1.740	5/16
2"	1.999	2.001	2.240	5/16
2-1/2	2.499	2.501	2.740	5/16
3"	2.999	3.001	3.365	1/2

L	D=1-1/2"		D=2"		D=2-1/2"		D=3"		L
	PFL	Cat. No.	PFL	Cat. No.	PFL	Cat. No.	PFL	Cat. No.	
3-3/4	1-3/8	1402							3-3/4
4-1/4	1-3/8	1403							4-1/4
4-3/4	1-3/8	1404							4-3/4
5-1/4	1-3/8	1405							5-1/4
5-3/4	1-3/8	1406	1-7/8	1606	2-3/8	1806			5-3/4
6-1/4	1-3/8	1407							6-1/4
6-3/4	1-3/8	1408	1-7/8	1608					
7-1/4									7-1/4
7-3/4	1-7/8	1410	1-7/8	1610	2-3/8	1810			7-3/4
8-1/4									8-1/4
8-3/4	1-7/8	1412	1-7/8	1612	2-3/8	1812			8-3/4
9-1/4									9-1/4
9-3/4	1-7/8	1414	1-7/8	1614	2-3/8	1814			9-3/4
10-1/4									10-1/4
10-3/4	1-7/8	1416	1-7/8	1616	2-3/8	1816			10-3/4
11-1/4									11-1/4
11-3/4	1-7/8	1418	1-7/8	1618	2-3/8	1818			11-3/4
12-1/4									12-1/4
12-3/4	1-7/8	1420	1-7/8	1620	2-3/8	1820	2-7/8	3020	12-3/4
13-3/4	1-7/8	1422	1-7/8	1622	2-3/8	1822			13-3/4
14-3/4	1-7/8	1424	1-7/8	1624	2-3/8	1824	2-7/8	3024	14-3/4
15-3/4	1-7/8	1426	1-7/8	1626	2-3/8	1826			15-3/4
16-3/4			2-3/8	1628	2-3/8	1828	2-7/8	3028	15-3/4
18-3/4			2-3/8	1632	2-3/8	1832	2-7/8	3032	18-3/4
NEW 36	2-3/8	LP1-1/2x36	2-3/8	LP2x36	2-3/8	LP2-1/2x36	2-7/8	LP3x36	36

# LEADER PINS

STRAIGHT — 3/4 — 1<sup>1/4</sup>

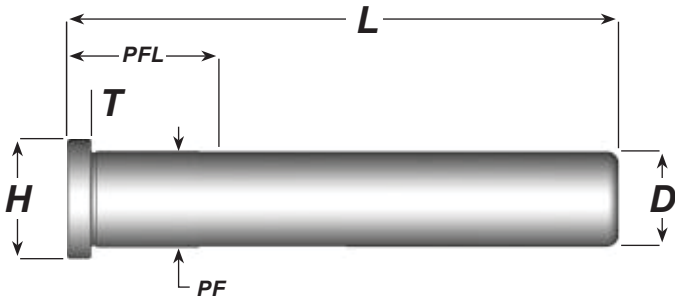
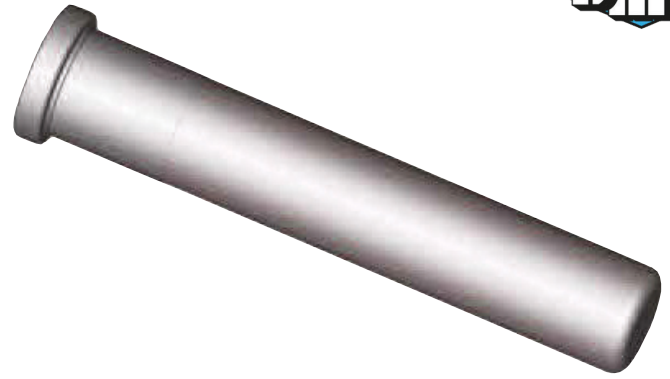

General Dimensions and Tolerances				
Nominal Diameter	D +.0000 -.0005	PF +.0005 -.0000	H +.000 -.010	T +.000 -.005
3/4	0.749	0.751	0.990	3/16
7/8	0.874	0.876	1.115	1/4
1"	0.999	1.001	1.240	1/4
1-1/4	1.249	1.251	1.490	5/16

L	D=3/4"		D=7/8"		D=1"		D=1-1/4"		L
	PFL	Cat. No.	PFL	Cat. No.	PFL	Cat. No.	PFL	Cat. No.	
1-3/4	7/8	1000	7/8	1099	7/8	1198			1-3/4
2-1/4	7/8	1001	7/8	1100	7/8	1199			2-1/4
2-3/4	7/8	1002	7/8	1101	7/8	1200	7/8	1300	2-3/4
3-1/4	7/8	1003	7/8	1102	7/8	1201	7/8	1301	3-1/4
3-3/4	7/8	1004	7/8	1103	7/8	1202	7/8	1302	3-3/4
4-1/4	1-3/8	1005	1-3/8	1104	1-3/8	1203	7/8	1303	4-1/4
4-3/4	1-3/8	1006	1-3/8	1105	1-3/8	1204	1-3/8	1304	4-3/4
5-1/4	1-3/8	1007	1-3/8	1106	1-3/8	1205	1-3/8	1305	5-1/4
5-3/4	1-7/8	1008	1-3/8	1107	1-3/8	1206	1-3/8	1306	5-3/4
6-1/4	1-7/8	1009	1-7/8	1108	1-3/8	1207	1-3/8	1307	6-1/4
6-3/4	1-7/8	1010	1-7/8	1109	1-7/8	1208	1-7/8	1308	6-3/4
7-1/4	1-7/8	1011	1-7/8	1110	1-7/8	1209	1-7/8	1309	7-1/4
7-3/4	1-7/8	1012	1-7/8	1111	1-7/8	1210	1-7/8	1310	7-3/4
8-1/4			1-7/8	1112	1-7/8	1211	1-7/8	1311	8-1/4
8-3/4			1-7/8	1113	1-7/8	1212	1-7/8	1312	8-3/4
9-1/4	1-7/8	1015			1-7/8	1213	1-7/8	1313	9-1/4
9-3/4					1-7/8	1214	1-7/8	1314	9-3/4
10-1/4					1-7/8	1215	1-7/8	1315	10-1/4
10-3/4			1-7/8	1117	1-7/8	1216	1-7/8	1316	10-3/4
11-1/4					1-7/8	1217	1-7/8	1317	11-1/4
11-3/4					1-7/8	1218	1-7/8	1318	11-3/4
12-1/4			1-7/8	1120	1-7/8	1219	1-7/8	1319	12-1/4
12-3/4							1-7/8	1320	12-3/4
13-3/4							1-7/8	1322	13-3/4
14-3/4							1-7/8	1324	14-3/4
15-3/4							1-7/8	1326	15-3/4
<b>NEW</b> 24					1-7/8	LP1x24	1-7/8	LP1-1/4x24	24

# LEADER PINS

SHOULDER — 3/4 — 1 1/4"

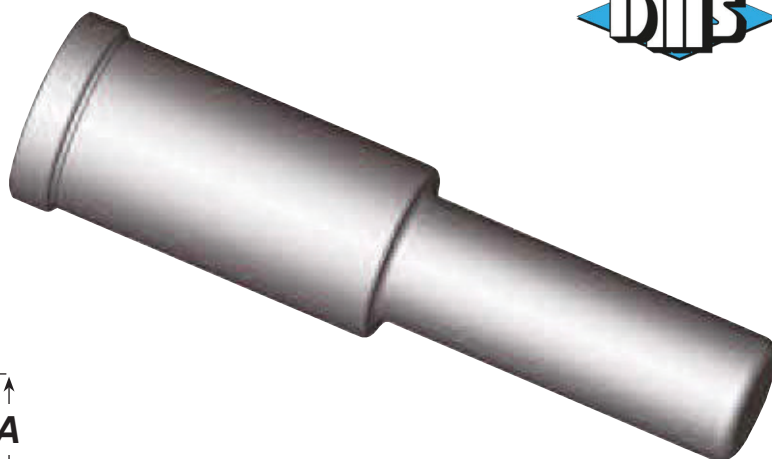
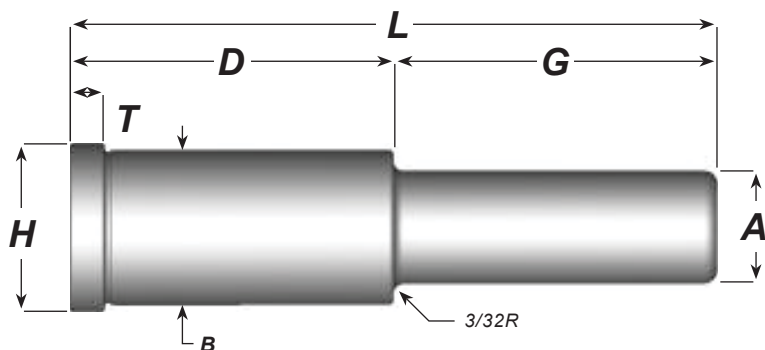

General Dimensions and Tolerances				
Nominal Diameter	A +.0000 -.0005	B +.0005 -.0000	H +.000 -.010	T +.000 -.005
3/4	0.749	1.126	1.250	5/16
1"	0.999	1.376	1.500	5/16
1-1/4	1.249	1.626	1.750	5/16

D	G	L	A=3/4	A=1"	A=1-1/4
7/8	7/8	1-3/4	70-707		
	1-3/8	2-1/4	70-713		
	2-3/8	3-1/4	70-723		
	2-7/8	3-3/4	70-727	10-727	
1-3/8	7/8	2-1/4	71-307		
	1-3/8	2-3/4	71-313	11-313	
	1-7/8	3-1/4	71-317	11-317	
	2-3/8	3-3/4	71-323		
	2-7/8	4-1/4	71-327	11-327	
	3-3/8	4-3/4	71-333	11-333	121-333
1-7/8	7/8	2-3/4	71-707		
	1-3/8	3-1/4	71-713	11-713	
	1-7/8	3-3/4	71-717	11-717	
	2-3/8	4-1/4	71-723	11-723	121-723
	2-7/8	4-3/4	71-727	11-727	121-727
	3-3/8	5-1/4	71-733	11-733	
	3-7/8	5-3/4	71-737		121-737
2-3/8	1-3/8	3-3/4	72-313	12-313	
	1-7/8	4-1/4	72-317	12-317	
	2-3/8	4-3/4	72-323	12-323	
	2-7/8	5-1/4	72-327	12-327	122-327
	3-3/8	5-3/4		12-333	
	3-7/8	6-1/4	72-337	12-337	122-337

D	G	L	A=3/4	A=1"	A=1-1/4
2-7/8	1-3/8	4-1/4	72-713		
	1-7/8	4-3/4	72-717	12-717	122-717
	2-3/8	5-1/4	72-723	12-723	122-723
	2-7/8	5-3/4	72-727	12-727	122-727
	3-3/8	6-1/4		12-733	
	3-7/8	6-3/4	72-737	12-737	
3-3/8	4-3/8	7-1/4		12-743	122-743
	1-7/8	5-1/4	73-317	13-317	
	2-3/8	5-3/4	73-323		123-323
	2-7/8	6-1/4		13-327	
	3-3/8	6-3/4	73-333	13-333	
3-7/8	4-3/8	7-3/4		13-343	123-343
	2-3/8	6-1/4	73-723	13-723	123-723
	2-7/8	6-3/4	73-727	13-727	123-727
	3-3/8	7-1/4			123-733
	3-7/8	7-3/4		13-737	123-737
	4-7/8	8-3/4		13-747	
4-3/8	2-7/8	7-1/4		14-327	
	3-3/8	7-3/4			124-333
	3-7/8	8-1/4		14-337	
	4-3/8	8-3/4			
	4-7/8	9-1/4			124-347
4-7/8	3-7/8	8-3/4		14-737	124-737
	4-3/8	9-1/4		14-743	
	4-7/8	9-3/4		14-747	124-747
5-7/8	5-7/8	10-3/4			124-757
	3-7/8	9-3/4		15-737	125-737
	4-3/8	10-1/4			125-743
	5-7/8	11-3/4			125-757

► Items in blue being discontinued. Available while supplies last. May be available as a per order item after depleted.

# GUIDED EJECTOR LEADER PINS

7/8 PRESS FIT

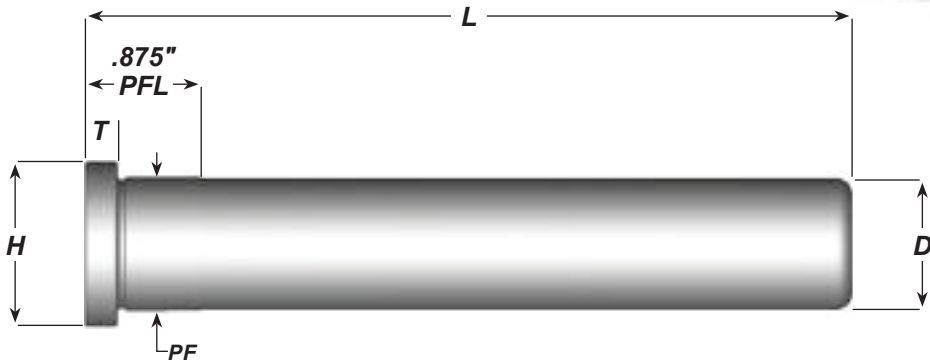
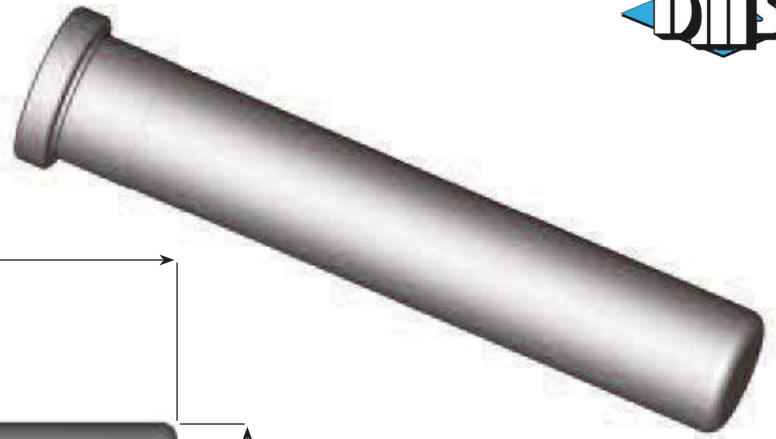

General Dimensions and Tolerances				
Nominal Diameter	D +.0000 -.0005	PF +.0005 -.0000	H +.000 -.010	T +.000 -.005
3/4	0.749	0.751	0.990	3/16
7/8	0.874	0.876	1.115	1/4
1"	0.999	1.001	1.240	1/4
1-1/4	1.249	1.251	1.490	5/16

L	D=3/4"	D=7/8"	D=1"	D=1-1/4"	L
	Cat. No	Cat. No	Cat. No	Cat. No	
4-1/4	1005-GLP	1104-GLP	1203-GLP	1303-GLP	4-1/4
4-3/4	1006-GLP	1105-GLP	1204-GLP	1304-GLP	4-3/4
5-1/4	1007-GLP	1106-GLP	1205-GLP	1305-GLP	5-1/4
5-3/4	1008-GLP	1107-GLP	1206-GLP	1306-GLP	5-3/4
6-1/4	1009-GLP	1108-GLP	1207-GLP	1307-GLP	6-1/4

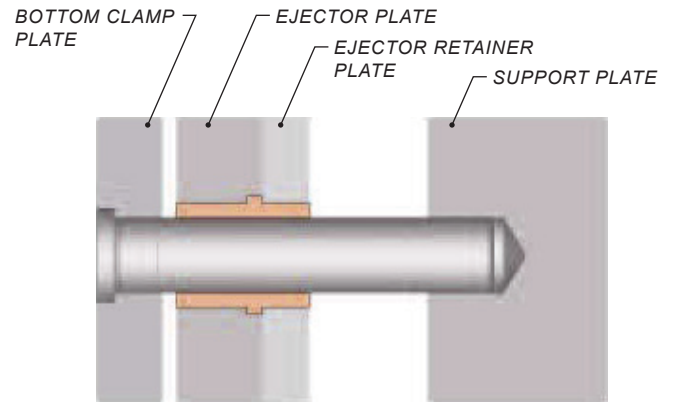

# LEADER PINS

SHOULDER — 1/2"

D	G	L	Cat. No.
7/8	7/8	1-3/4	500-707
	1-3/8	2-1/4	500-713
	1-7/8	2-3/4	500-717
	2-3/8	3-1/4	500-723
1-3/8	7/8	2-1/4	501-307
	1-3/8	2-3/4	501-313
	1-7/8	3-1/4	501-317
1-7/8	7/8	2-3/4	501-707
	1-3/8	3-1/4	501-713
	1-7/8	3-3/4	501-717
2-3/8	7/8	3-1/4	502-307
2-7/8	1-3/8	4-1/4	502-713

Leader Pins General Dimensions and Tolerances				
Nominal Diameter	A	B	H	T
1/2	+0.000 -0.005	+0.0005 -0.0000	+0.000 -0.010	+0.000 -0.005
	0.499	0.751	0.853	3/16

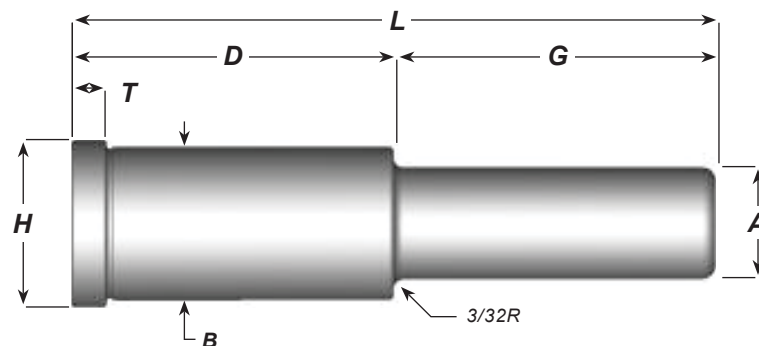
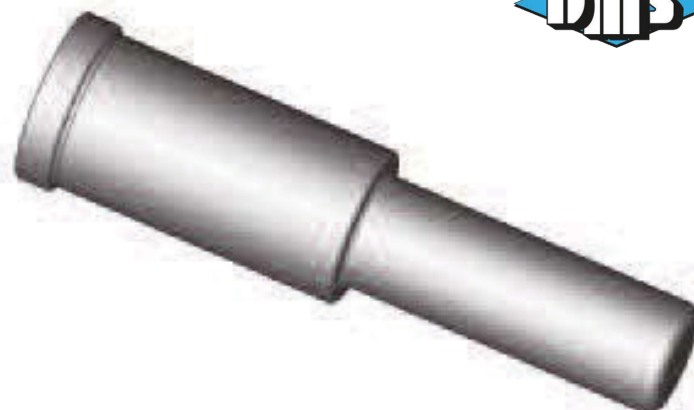

# SHOULDER BUSHINGS

1/2"

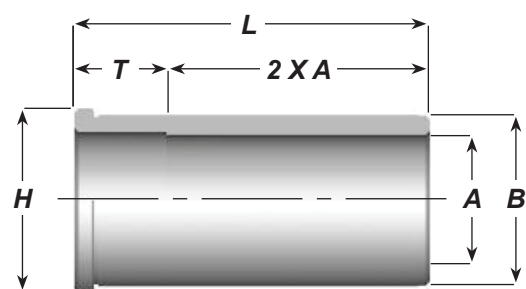

L	Cat. No.
7/8	505-690
1-3/8	505-691
1-7/8	505-692
2-3/8	505-693



Shoulder Bushings General Dimensions and Tolerances				
Nominal Diameter	A	B	H	T
1/2	+0.0005 -0.0000	+0.0005 -0.0000	+0.000 -0.010	+0.000 -0.005
	.500	.7505	.853	3/16

# STRAIGHT BUSHINGS

1/2"

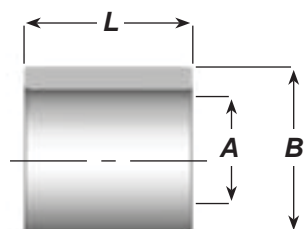

L	Cat. No.
7/8	505-498
1-3/8	505-499



Straight Bushings General Dimensions and Tolerances		
Nominal Diameter	A	B
1/2	+0.0005 -0.0000	+0.0005 -0.0000
	0.500	0.751

# LEADER PINS

## METRIC

20mm through 60mm

Not all pins are ground on centers.

GENERAL DIMENSIONS				
NOM. PIN	D1 +0.000	D2 +0.013	D3 +0.00	L2 +0.00
DIA.	-0.013	0.000	-0.26	-0.05
20	19.975	20.025	25.00	5.00
25	24.975	25.025	31.00	6.00
30	29.975	30.025	36.00	8.00
40	39.975	40.025	46.00	8.00
50	49.975	50.025	56.00	8.00
60	59.975	60.025	66.00	8.00

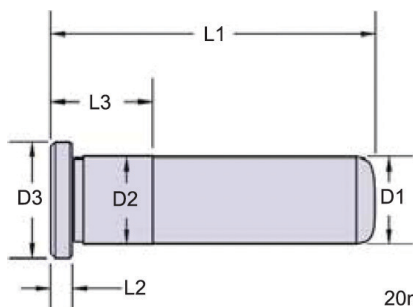

Leader Pins - Metric												
L1 Overall Length	NOMINAL DIA. 20mm		NOMINAL DIA. 25mm		NOMINAL DIA. 30mm		NOMINAL DIA. 40mm		NOMINAL DIA. 50mm		NOMINAL DIA. 60mm	
	PART NUMBER	L3	PART NUMBER	L3	PART NUMBER	L3	PART NUMBER	L3	PART NUMBER	L3	PART NUMBER	L3
50mm	MLP20x50	25mm	MLP25x50	25mm								
60mm	MLP20x60	25mm	MLP25x60	25mm								
70mm	MLP20x70	25mm	MLP25x70	25mm	MLP30x70	25mm						
80mm	MLP20x80	25mm	MLP25x80	25mm	MLP30x80	25mm						
90mm	MLP20x90	25mm	MLP25x90	25mm	MLP30x90	25mm	MLP40x90	35mm				
100mm	MLP20x100	25mm	MLP25x100	25mm	MLP30x100	25mm	MLP40x100	35mm				
120mm	MLP20x120	35mm	MLP25x120	35mm	MLP30x120	35mm	MLP40x120	35mm				
140mm	MLP20x140	35mm	MLP25x140	35mm	MLP30x140	35mm	MLP40x140	35mm				
150mm									MLP50x150	45mm	MLP60x150	60mm
160mm	MLP20x160	35mm	MLP25x160	35mm	MLP30x160	35mm	MLP40x160	35mm				
175mm									MLP50x175	45mm	MLP60x175	60mm
180mm	MLP20x180	45mm	MLP25x180	45mm	MLP30x180	45mm	MLP40x180	45mm				
200mm	MLP20x200	45mm	MLP25x200	45mm	MLP30x200	45mm	MLP40x200	45mm	MLP50x200	45mm	MLP60x200	60mm
220mm	MLP20x220	45mm	MLP25x220	45mm	MLP30x220	45mm	MLP40x220	45mm				
225mm									MLP50x225	45mm	MLP60x225	60mm
240mm	MLP20x240	45mm	MLP25x240	45mm	MLP30x240	45mm	MLP40x240	45mm				
250mm									MLP50x250	45mm	MLP60x250	60mm
260mm			MLP25x260	45mm	MLP30x260	45mm	MLP40x260	45mm				
275mm									MLP50x275	45mm	MLP60x275	60mm
280mm			MLP25x280	45mm	MLP30x280	45mm						
300mm			MLP25x300	45mm	MLP30x300	45mm	MLP40x300	45mm	MLP50x300	45mm	MLP60x300	60mm
325mm									MLP50x325	45mm	MLP60x325	60mm
350mm									MLP50x350	45mm	MLP60x350	60mm
375mm									MLP50x375	45mm	MLP60x375	60mm
400mm									MLP50x400	45mm	MLP60x400	60mm

# SHOULDER BUSHINGS

## STEEL



General Dimensions and Tolerances				
Nominal I.D.	A +0.0005 -0.0000	B +0.0005 -0.0000	H +0.000 -0.010	T +0.000 -0.005
3/4	0.751	1.126	1.250	3/16
7/8	0.876	1.251	1.375	3/16
1"	1.001	1.376	1.500	3/16
1-1/4	1.251	1.626	1.750	3/16
1-1/2	1.501	2.001	2.125	3/16
2"	2.001	2.501	2.625	3/16
2-1/2	2.501	3.251	3.375	3/16
3"	3.001	3.751	3.937	1/2

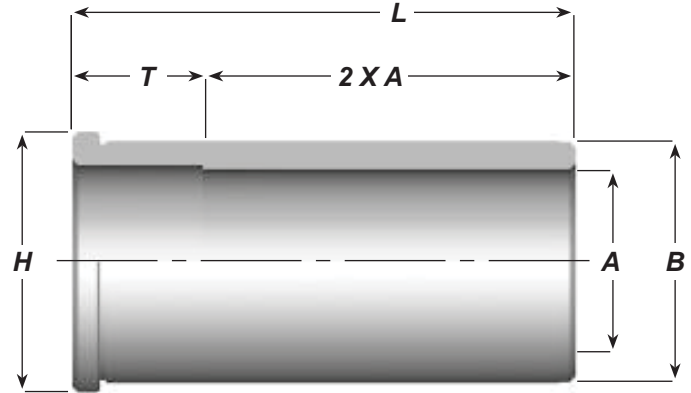

L	CATALOG NUMBER				L
	A=3/4"	A=7/8"	A=1"	A=1-1/4"	
7/8	2700	2710	2730	2750	7/8
1-3/8	2701	2711	2731	2751	1-3/8
1-7/8	2702	2712	2732	2752	1-7/8
2-3/8	2703	2713	2733	2753	2-3/8
2-7/8	2704	2714	2734	2754	2-7/8
3-3/8	2705	2715	2735	2755	3-3/8
3-7/8	2706	2716	2736	2756	3-7/8
4-3/8	2707	2717	2737	2757	4-3/8
4-7/8	2708	2718	2738	2758	4-7/8
5-7/8	2709	2720	2740	2760	5-7/8
7-7/8					7-7/8

L	CATALOG NUMBER				L
	A=1-1/2"	A=2"	A=2-1/2"	A=3"	
7/8	2770				7/8
1-3/8	2771	2901	2951		1-3/8
1-7/8	2772	2902	2952		1-7/8
2-3/8	2773	2903	2953		2-3/8
2-7/8	2774	2904	2954		2-7/8
3-3/8	2775	2905	2955		3-3/8
3-7/8	2776	2906	2956	3976	3-7/8
4-3/8	2777	2907	2957		4-3/8
4-7/8	2778	2908	2958	3978	4-7/8
5-7/8	2780	2910	2960	3980	5-7/8
7-7/8				3984	7-7/8



# SHOULDER BUSHINGS

## SOLID BRONZE

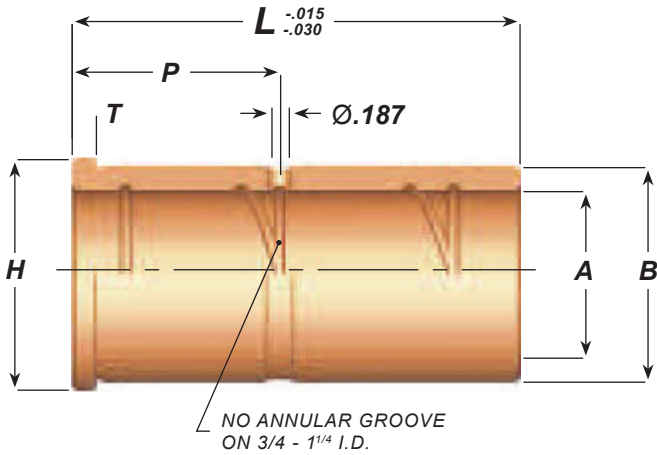
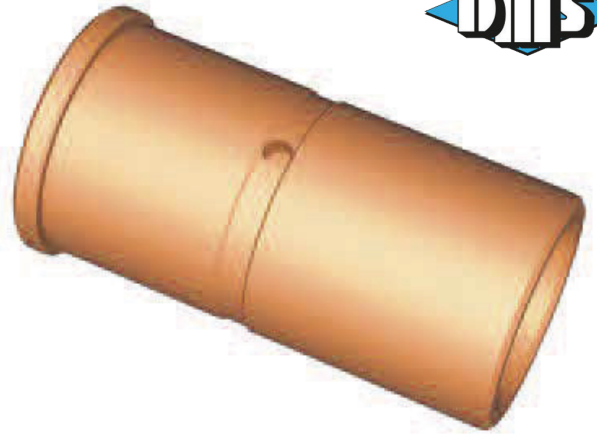

General Dimensions and Tolerances				
Nominal I.D.	A +.0005 -.0000	B +.0005 -.0000	H +.000 -.010	T +.000 -.005
3/4	0.751	1.126	1.302	3/16
7/8	0.876	1.251	1.427	3/16
1"	1.001	1.376	1.552	3/16
1-1/4	1.251	1.626	1.802	3/16
1-1/2	1.501	2.001	2.177	3/16
2"	2.001	2.501	2.677	3/16
2-1/2	2.501	3.251	3.427	3/16
3"	3.001	3.751	3.990	1/2

L	P	CATALOG NUMBER								L
		A=3/4"	A=7/8"	A=1"	A=1-1/4"	A=1-1/2"	A=2"	A=2-1/2"	A=3"	
7/8	*	2700SB	2710SB	2730SB	2750SB	2770SB	-	-	-	7/8
1-3/8	0.56	2701SB	2711SB	2731SB	2751SB	2771SB	2901SB	2951SB	-	1-3/8
1-7/8	0.56	2702SB	2712SB	2732SB	2752SB	2772SB	2902SB	2952SB	-	1-7/8
2-3/8	1.56	2703SB	2713SB	2733SB	2753SB	2773SB	2903SB	2953SB	-	2-3/8
2-7/8	1.56	2704SB	2714SB	2734SB	2754SB	2774SB	2904SB	2954SB	-	2-7/8
3-3/8	1.56	2705SB	2715SB	2735SB	2755SB	2775SB	2905SB	2955SB	-	3-3/8
3-7/8	1.56	2706SB	2716SB	2736SB	2756SB	2776SB	2906SB	2956SB	3976SB	3-7/8
4-3/8	1.56	2707SB	2717SB	2737SB	2757SB	2777SB	2907SB	2957SB	-	4-3/8
4-7/8	1.56	2708SB	2718SB	2738SB	2758SB	2778SB	2908SB	2958SB	3978SB	4-7/8
5-7/8	1.56	2709SB	2720SB	2740SB	2760SB	2780SB	2910SB	2960SB	3980SB	5-7/8
7-7/8	-	-	-	-	-	-	-	-	3984SB	7-7/8

➤ No grease groove or hole on 7/8 long bushings.

# SHOULDER BUSHINGS

## SELF-LUBRICATING



General Dimensions and Tolerances				
Nominal I.D.	A +0.0005 -0.0000	B +0.0005 -0.0000	H +0.000 -0.005	T +0.000 -0.005
3/4	0.751	1.126	1.302	3/16
7/8	0.876	1.251	1.427	3/16
1"	1.001	1.376	1.552	3/16
1-1/4	1.251	1.626	1.802	3/16
1-1/2	1.501	2.001	2.177	3/16
2"	2.001	2.501	2.677	3/16
2-1/2	2.501	3.251	3.427	3/16
3"	3.001	3.751	3.990	1/2

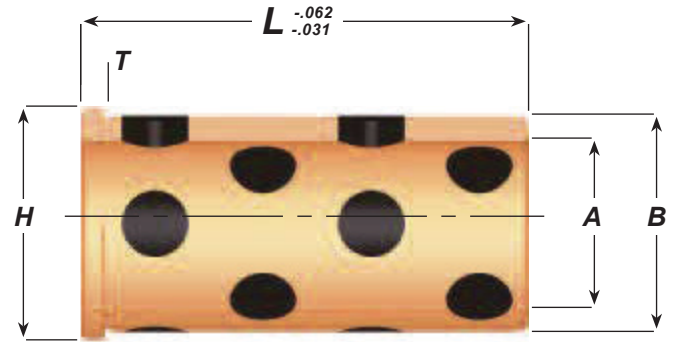

L	CATALOG NUMBER				L
	A=3/4"	A=7/8"	A=1"	A=1-1/4"	
7/8	2700SL	2710SL	2730SL	2750SL	7/8
1-3/8	2701SL	2711SL	2731SL	2751SL	1-3/8
1-7/8	2702SL	2712SL	2732SL	2752SL	1-7/8
2-3/8	2703SL	2713SL	2733SL	2753SL	2-3/8
2-7/8	2704SL	2714SL	2734SL	2754SL	2-7/8
3-3/8	2705SL	2715SL	2735SL	2755SL	3-3/8
3-7/8	2706SL	2716SL	2736SL	2756SL	3-7/8
4-3/8	2707SL	2717SL	2737SL	2757SL	4-3/8
4-7/8	2708SL	2718SL	2738SL	2758SL	4-7/8
5-7/8	2709SL	2720SL	2740SL	2760SL	5-7/8
7-7/8					7-7/8

L	CATALOG NUMBER				L
	A=1-1/2"	A=2"	A=2-1/2"	A=3"	
7/8	2770SL				7/8
1-3/8	2771SL	2901SL	2951SL		1-3/8
1-7/8	2772SL	2902SL	2952SL		1-7/8
2-3/8	2773SL	2903SL	2953SL		2-3/8
2-7/8	2774SL	2904SL	2954SL		2-7/8
3-3/8	2775SL	2905SL	2955SL		3-3/8
3-7/8	2776SL	2906SL	2956SL	3976SL	3-7/8
4-3/8	2777SL	2907SL	2957SL		4-3/8
4-7/8	2778SL	2908SL	2958SL	3978SL	4-7/8
5-7/8	2780SL	2910SL	2960SL	3980SL	5-7/8
7-7/8				3984SL	7-7/8

# SHOULDER BUSHINGS

## BRONZE-PLATED

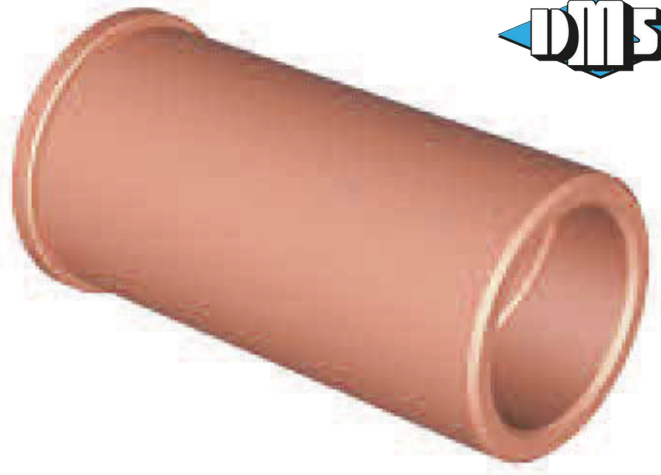

General Dimensions and Tolerances				
Nominal I.D.	A +.0005 -.0000	B +.0005 -.0000	H +.000 -.015	T +.000 -.005
3/4	0.751	1.126	1.302	3/16
7/8	0.876	1.251	1.427	3/16
1"	1.001	1.376	1.552	3/16
1-1/4	1.251	1.626	1.802	3/16
1-1/2	1.501	2.001	2.177	3/16
2"	2.001	2.501	2.677	3/16
2-1/2	2.501	3.251	3.427	3/16
3"	3.001	3.751	3.990	1/2

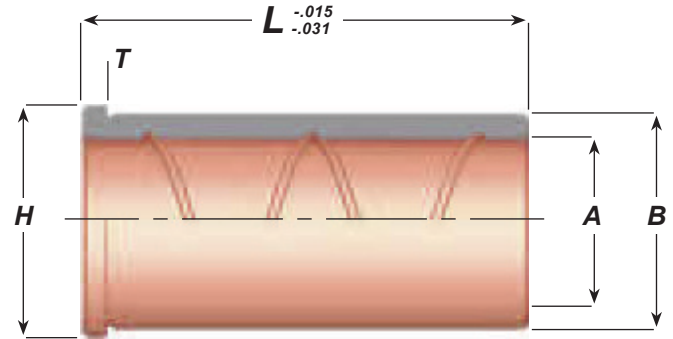

L	CATALOG NUMBER				L
	A=3/4"	A=7/8"	A=1"	A=1-1/4"	
7/8	LBB-06-07	LBB-07-07	LBB-08-07	LBB-10-07	7/8
1-3/8	LBB-06-13	LBB-07-13	LBB-08-13	LBB-10-13	1-3/8
1-7/8	LBB-06-17	LBB-07-17	LBB-08-17	LBB-10-17	1-7/8
2-3/8	LBB-06-23	LBB-07-23	LBB-08-23	LBB-10-23	2-3/8
2-7/8	LBB-06-27	LBB-07-27	LBB-08-27	LBB-10-27	2-7/8
3-3/8	LBB-06-33	LBB-07-33	LBB-08-33	LBB-10-33	3-3/8
3-7/8	LBB-06-37	LBB-07-37	LBB-08-37	LBB-10-37	3-7/8
4-3/8	LBB-06-43	LBB-07-43	LBB-08-43	LBB-10-43	4-3/8
4-7/8	LBB-06-47	LBB-07-47	LBB-08-47	LBB-10-47	4-7/8
5-7/8	LBB-06-57	LBB-07-57	LBB-08-57	LBB-10-57	5-7/8
7-7/8					7-7/8

L	CATALOG NUMBER				L
	A=1-1/2"	A=2"	A=2-1/2"	A=3"	
7/8	LBB-12-07				7/8
1-3/8	LBB-12-13	LBB-16-13	LBB-20-13		1-3/8
1-7/8	LBB-12-17	LBB-16-17	LBB-20-17		1-7/8
2-3/8	LBB-12-23	LBB-16-23	LBB-20-23		2-3/8
2-7/8	LBB-12-27	LBB-16-27	LBB-20-27		2-7/8
3-3/8	LBB-12-33	LBB-16-33	LBB-20-33		3-3/8
3-7/8	LBB-12-37	LBB-16-37	LBB-20-37	LBB-24-37	3-7/8
4-3/8	LBB-12-43	LBB-16-43	LBB-20-43		4-3/8
4-7/8	LBB-12-47	LBB-16-47	LBB-20-47	LBB-24-47	4-7/8
5-7/8	LBB-12-57	LBB-16-57	LBB-20-57	LBB-24-57	5-7/8
7-7/8				LBB-24-77	7-7/8

# SHOULDER BUSHINGS

SOLID BRONZE — METRIC

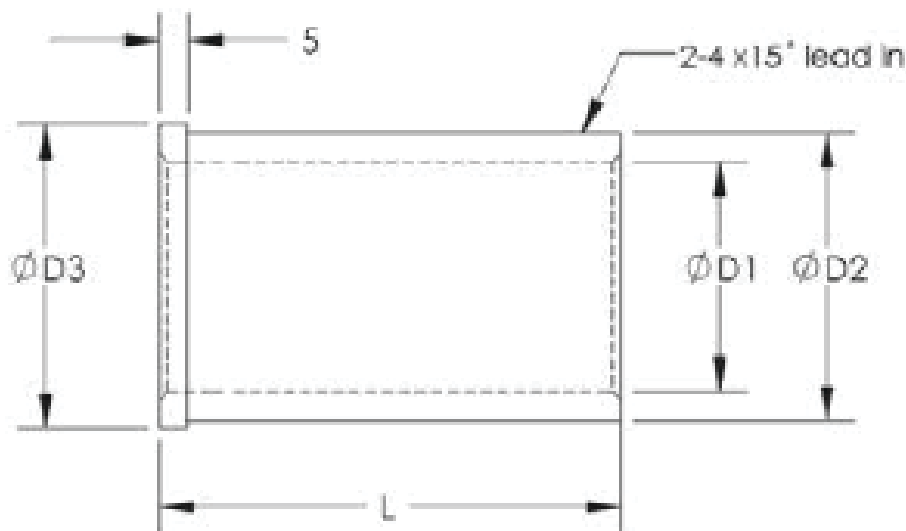

\*\*WITH GREASE GROOVES\*\*

L	Nominal I.D.					
	20	25	30	40	50	60
25.00	LBBM20x25	LBBM25x25	LBBM30x25	LBBM40x25	—	—
30.00	LBBM20x30	LBBM25x30	LBBM30x30	LBBM40x30	LBBM50x30	LBBM60x30
40.00	LBBM20x40	LBBM25x40	LBBM30x40	LBBM40x40	LBBM50x40	LBBM60x40
50.00	LBBM20x50	LBBM25x50	LBBM30x50	LBBM40x50	LBBM50x50	LBBM60x50
65.00	LBBM20x65	LBBM25x65	LBBM30x65	LBBM40x65	LBBM50x65	LBBM60x65
80.00	LBBM20x80	LBBM25x80	LBBM30x80	LBBM40x80	LBBM50x80	LBBM60x80
100.00	LBBM20x100	LBBM25x100	LBBM30x100	LBBM40x100	LBBM50x100	LBBM60x100
120.00	LBBM20x120	LBBM25x120	LBBM30x120	LBBM40x120	LBBM50x120	LBBM60x120
140.00	—	LBBM25x140	LBBM30x140	LBBM40x140	LBBM50x140	LBBM60x140
150.00	—	LBBM25x150	LBBM30x150	LBBM40x150	LBBM50x150	LBBM60x150

GENERAL DIMENSIONS			
Nom.	D1	D2	D3
I.D.	+0.013 -0.000	+0.013 -0.000	+0.00 -0.13
20	20.013	26.013	28.00
25	25.013	32.013	35.00
30	30.013	38.013	41.00
40	40.013	50.013	53.00
50	50.013	60.013	63.00
60	60.013	70.013	73.00

Materials: Aluminum Bronze

Tolerances: L: +0.00/-0.76

# STRAIGHT BUSHINGS

STEEL

Catalog Number	Nominal I.D.	A I.D. +.0005 -.0000	B O.D. +.0005 -.0000	L -.015 -.030
2500	3/4	0.751	1.126	7/8
2501	3/4	0.751	1.126	1-3/8
2502	7/8	0.876	1.251	1-3/8
2503	1"	1.001	1.376	1-3/8
2504	1-1/4	1.251	1.626	1-3/8
2505	1-1/4	1.251	1.626	1-7/8
2506	1-1/2	1.501	2.001	1-3/8
2507	1-1/2	1.501	2.001	1-7/8
2508	2"	2.001	2.501	3-7/8
2509	2-1/2	2.501	3.251	4-7/8
2510	3	3.005	3.751	4-7/8

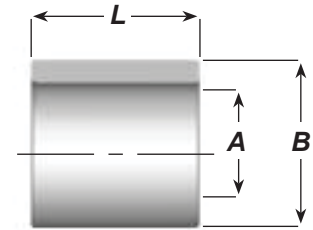

# STRAIGHT BUSHINGS

SOLID BRONZE

Catalog Number	Nominal I.D.	A I.D.	B O.D.	P	L
		+ .0005 - .0000	+ .0005 - .0000		- .015 - .030
2500SB	3/4	0.751	1.126	*	7/8
2501SB	3/4	0.751	1.126	0.56	1-3/8
2502SB	7/8	0.876	1.251	0.56	1-3/8
2503SB	1"	1.001	1.376	0.56	1-3/8
2504SB	1-1/4	1.251	1.626	0.56	1-3/8
2505SB	1-1/4	1.251	1.626	0.56	1-7/8
2506SB	1-1/2	1.501	2.001	0.56	1-3/8
2507SB	1-1/2	1.501	2.001	0.56	1-7/8
2508SB	2"	2.001	2.501	1.56	3-7/8
2509SB	2.5"	2.501	3.251	0.56	4 -7/8
2510SB	3"	3.001	3.751	1.56	4 -7/8

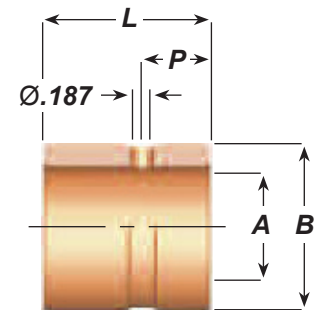

► No grease groove or hole on 7/8 long bushings.



# STRAIGHT BUSHINGS

## BRONZE-PLATED

Catalog Number	Nominal I.D.	A.I.D.	B.O.D.	L
		+0.0005 -0.0000	+0.0005 -0.0000	-0.031 -0.062
STB-06-07	3/4	0.751	1.126	7/8
STB-06-13	3/4	0.751	1.126	1-3/8
STB-07-13	7/8	0.876	1.251	1-3/8
STB-08-13	1"	1.001	1.376	1-3/8
STB-10-13	1-1/4	1.251	1.626	1-3/8
STB-10-17	1-1/4	1.251	1.626	1-7/8
STB-12-13	1-1/2	1.501	2.001	1-3/8
STB-12-17	1-1/2	1.501	2.001	1-7/8
STB-16-37	2"	2.001	2.501	3-7/8
STB-20-47	2-1/2	2.501	3.251	4-7/8
STB-24-47	3"	3.001	3.751	4-7/8

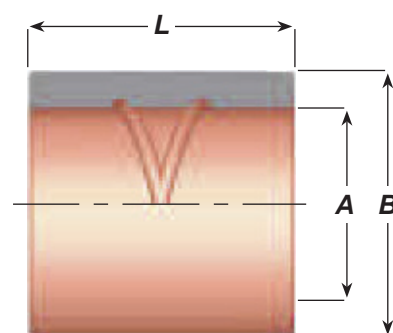
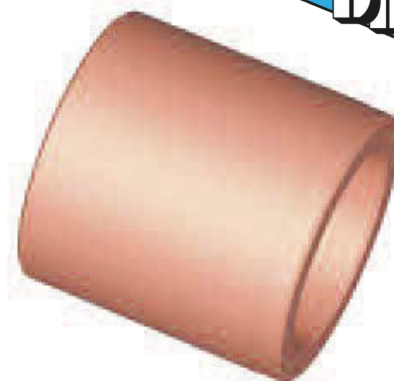

# STRAIGHT BUSHINGS

## SELF-LUBRICATING

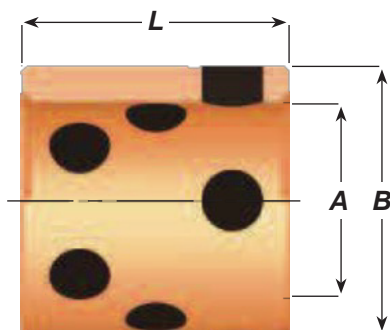

L	CATALOG NUMBER								L
	A=3/4"	A=7/8"	A=1"	A=1-1/4"	A=1-1/2"	A=2"	A=2-1/2"	A=3"	
1/3	STB-06-07	STB-07-13							
7/8	SB0607SL								7/8
1-1/4		SB710SL	SB0810SL	SB1010SL	SB1210SL	SB1610SL			1-1/4
1-3/8	SB0611SL	SB711SL	SB0811SL	SB1011SL	SB1211SL				1-3/8
1-1/2	SB0612SL	SB0712SL	SB0812SL	SB1012SL	SB1212SL	SB1612SL	SB2012SL		1-1/2
1-3/4			SB0814SL	SB1014SL	SB1214SL	SB1614SL			1-3/4
1-7/8				SB1015SL	SB1215SL				1-7/8
2"			SB0816SL	SB1016SL	SB1216SL	SB1616SL	SB2016SL	SB2416SL	2"
2-1/2						SB1620SL		SB2420SL	2-1/2
3"			SB0824SL	SB1024SL	SB1224SL	SB1624SL	SB2024SL	SB2424SL	3"
3-1/2								SB2428SL	3-1/2
3-7/8						SB1631SL			3-7/8
4-7/8						SB1639SL	SB2039SL	SB2439SL	4-7/8

# GUIDED EJECTOR BUSHINGS

STEEL

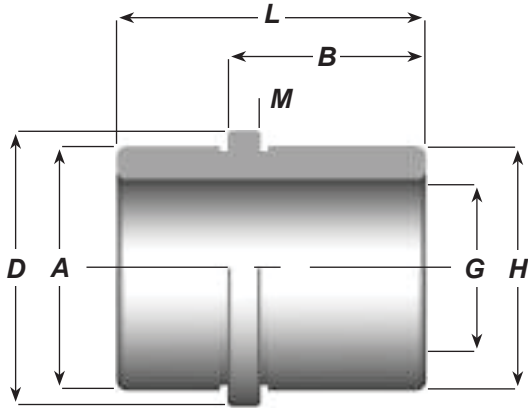

Nominal I.D.	G	H	A	D	L	B	M	Catalog Number
	+0.001 0.000	+0.0005 -0.0000	+0.000 -0.001	+0.000 -0.010	+0.000 -0.030	+0.000 -0.015	+0.000 -0.005	
3/4	0.751	1.126	1.124	1.302	1.50	1.00	0.187	GEB-06
7/8	0.876	1.251	1.249	1.427	1.50	1.00	0.187	GEB-07
1"	1.001	1.376	1.374	1.552	1.75	1.12	0.187	GEB-08
1-1/4	1.251	1.626	1.624	1.802	1.75	1.12	0.187	GEB-10
1-1/2	1.501	2.001	1.999	2.177	1.75	1.12	0.187	GEB-12

# GUIDED EJECTOR BUSHINGS

SOLID BRONZE

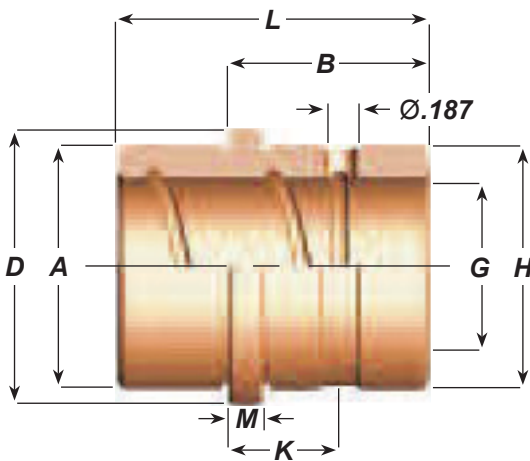

Nominal I.D.	G	H	A	D	L	B	M	K	Catalog Number
	+0.0005 -0.0000	+0.0005 -0.0000	+0.000 -0.001	+0.000 -0.010	+0.000 -0.030	+0.000 -0.015	+0.000 -0.005		
1/2	0.501	0.7505	0.749	0.853	1.50	1.00	0.187	0.56	GEB05SB
3/4	0.751	1.126	1.124	1.302	1.50	1.00	0.187	0.560	GEB-06SB
7/8	0.876	1.251	1.249	1.427	1.50	1.00	0.187	0.560	GEB-07SB
1"	1.001	1.376	1.374	1.552	1.75	1.12	0.187	0.620	GEB-08SB
1-1/4	1.251	1.626	1.624	1.802	1.75	1.12	0.187	0.620	GEB-10SB
1-1/2	1.501	2.001	1.999	2.177	1.75	1.12	0.187	0.620	GEB-12SB
1-1/2	1.501	2.001	1.999	2.177	2.5	1.875	0.187	0.620	GEB12SBX
2"	2.001	2.501	2.499	2.687	2.25	1.62	0.187	0.800	GEB-20SB

# GUIDED EJECTOR BUSHINGS

BRONZE-PLATED

Nominal I.D.	G	H	A	D	L	B	M	K	Catalog Number
	+0.005 -0.000	+0.005 -0.000	+0.000 -0.001	+0.000 -0.010	+0.000 -0.030	+0.000 -0.015	+0.000 -0.005		
3/4	0.751	1.126	1.124	1.302	1.50	1.00	0.187	0.560	ELB-750
7/8	0.876	1.251	1.249	1.427	1.50	1.00	0.187	0.560	ELB-875
1"	1.001	1.376	1.374	1.552	1.75	1.12	0.187	0.620	ELB-100
1-1/4	1.251	1.626	1.624	1.802	1.75	1.12	0.187	0.620	ELB-125
1-1/2	1.501	2.001	1.999	2.177	1.75	1.12	0.187	0.620	ELB-150
2"	2.001	2.501	2.499	2.687	2.25	1.62	0.187	0.800	ELB-200

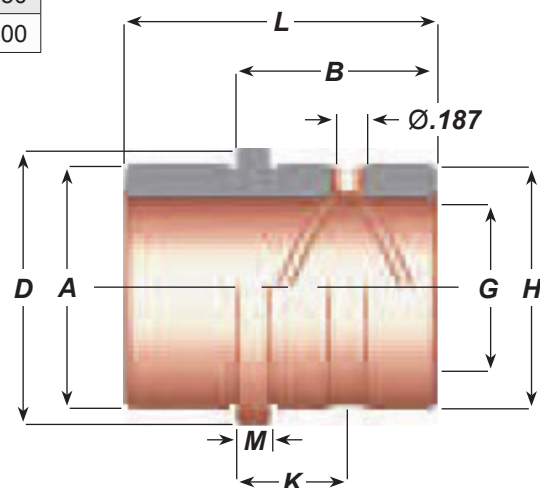

# GUIDED EJECTOR BUSHINGS

SELF-LUBRICATING

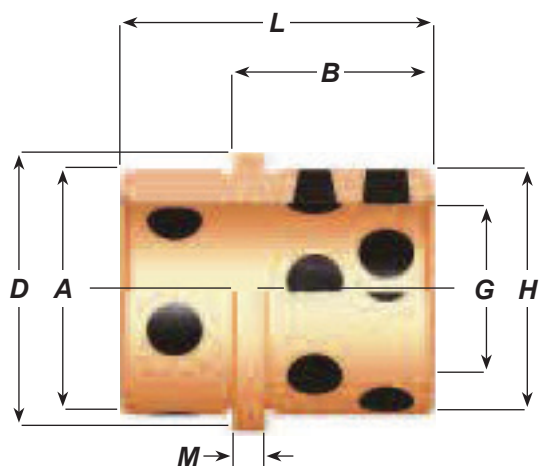

Nominal I.D.	G	H	A	D	L	B	M	Catalog Number
	+0.005 -0.000	+0.005 -0.000	+0.000 -0.001	+0.000 -0.010	+0.000 -0.030	+0.000 -0.015	+0.000 -0.005	
3/4	0.751	1.126	1.124	1.302	1.500	1.000	0.187	GEB-06SL
7/8	0.876	1.251	1.249	1.427	1.500	1.000	0.187	GEB-07SL
1"	1.001	1.376	1.374	1.552	1.750	1.125	0.187	GEB-08SL
1"	1.001	1.376	1.374	1.552	2.000	1.625	0.187	GEB-08SLX
1-1/4	1.251	1.626	1.624	1.802	1.750	1.125	0.187	GEB-10SL
1-1/4	1.251	1.626	1.624	1.802	2.500	1.875	0.187	GEB-10SLX
1-1/2	1.501	2.001	1.999	2.177	1.750	1.125	0.187	GEB-12SL
1-1/2	1.501	2.001	1.999	2.177	2.500	1.875	0.187	GEB-12SLX
2"	2.001	2.501	2.499	2.687	2.250	1.625	0.187	GEB-20SL

# BALL-GUIDED EJECTOR BUSHINGS

BOLEXP® INCH SERIES

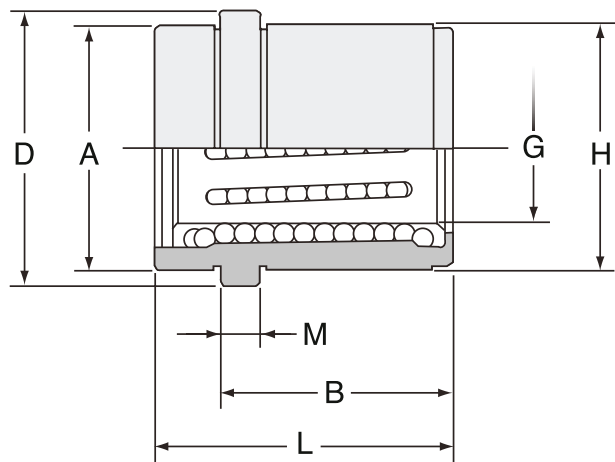

Nom. I.D.	G	H +0.0005 -0.0000	A +0.000 -0.001	D +0.000 -0.030	L +0.000 -0.030	B +0.000 -0.030	M +0.000 -0.005	Catalog Number
3/4	0.751	1.251	1.249	1.427	1.50	1.00	0.187	BGEB0750
7/8	0.876	1.376	1.374	1.552	1.75	1.12	0.187	BGEB0875
1"	1.001	1.626	1.624	1.802	1.75	1.12	0.187	BGEB1000
1-1/4	1.251	2.001	1.999	2.177	1.75	1.12	0.187	BGEB1250
1-1/2	1.501	2.501	2.499	2.687	2.25	1.62	0.187	BGEB1500

**Material:** Special roll steel bush casing, hardened & ground which holds fixed inside a high-resistant bronze cage for guiding the balls running along the cage. The unique feature of these bushings is that the balls do not run aligned, but at a slight angle thus enlarging the contact area and enabling greater load capacity. This system allows the precision balls to circulate endlessly.

Typically for use in the ejector system when a "friction free" application is required. Use DMS "Press Fit" Leader pins with these in the guided ejector system.

**Fitting:** Ensure that the leader pin holes in the clamp plate and the bores in the ejector set are square and in line. It is recommended to mount at least two units.

**Lubrication:** The bushings are supplied oiled and must be lubricated when necessary. Proper lubrication and maintenance are a must. The channels that the balls run along must be free and clear of ANY particles, thus the removal of all impurities is essential.

It is recommended to use oils within the range of ISO viscosities from ISO VG 64 to 100.

A complete range of metric ejector, shoulder and straight bushings are also available. Please visit [www.bolexp.com](http://www.bolexp.com) or call DMS for further information.

**Materials:** Special steel bush.

Bronze cage with high resistance to wear.

- High-precision balls.
- Hardness: 60-62 HRc.
- Max Operating temp: 110-125°C.



EXPLODED VIEW

# GUIDED EJECTION SUPPORT PILLARS

INCH

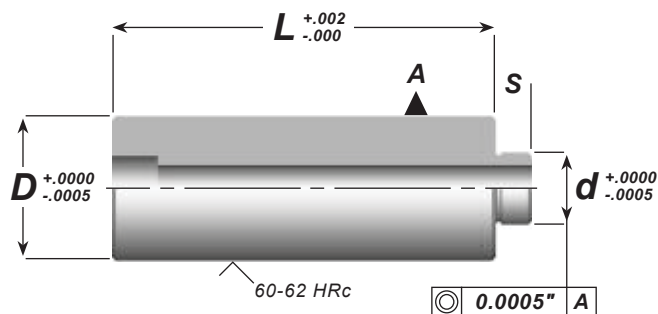

D	d	S	CATALOG NUMBER						
			L=2-1/2"	L=3"	L=3-1/2"	L=4"	L=4-1/2"	L=5"	L=6"
3/4	0.468	0.281	SSP07525	SSP07530	SSP07535	SSP07540			
1"	0.500	0.312	SSP10025	SSP10030	SSP10035	SSP10040	SSP10045		
1-1/4	0.687	0.312	SSP12525	SSP12530	SSP12535	SSP12540	SSP12545	SSP12550	SSP12560
1-1/2	0.750	0.375	SSP15025	SSP15030	SSP15035	SSP15040	SSP15045	SSP15050	SSP15060
2"	0.750	0.375	SSP20025	SSP20030	SSP20035	SSP20040	SSP20045	SSP20050	SSP20060

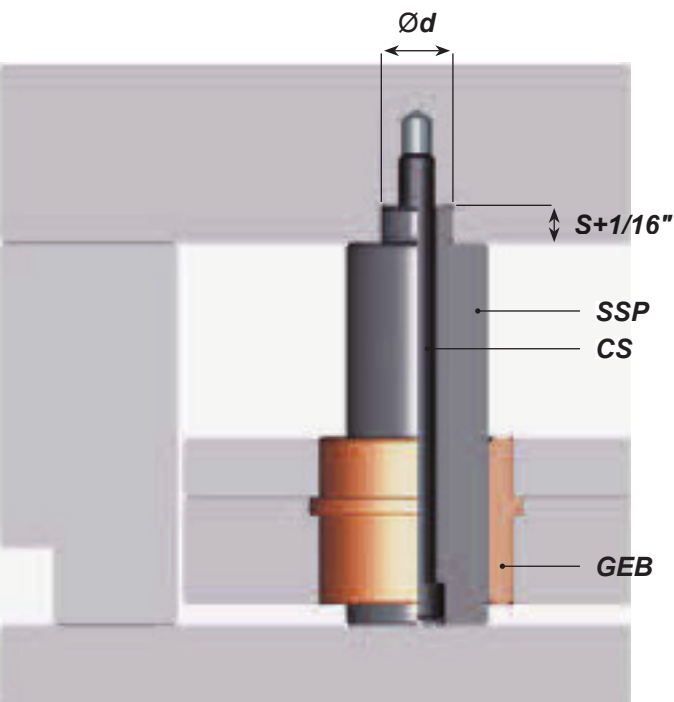

- > Available in standard lengths.
- > Case hardened.
- > For use with any standard guided ejector bushing.
- > Bottom clamp plate machining is not required.
- > No press fit concerns.
- > Ejector set machining is significantly reduced.

DESIGN INFORMATION			
D	Depth of reamed hole for 'd'	Tapped hole depth for capscrew	Capscrew (supplied)
3/4	0.343	0.468	1/4-20 x L+.250
1"	0.375	0.562	5/16-18 x L+.500
1-1/4	0.375	0.562	5/16-18 x L+.500
1-1/2	0.437	0.656	3/8-16 x L+.500
2"	0.437	0.656	3/8-16 x L+.500



# GUIDED EJECTION SUPPORT PILLARS

METRIC

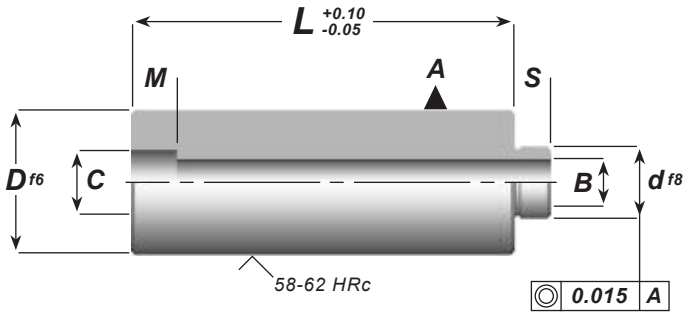

D	C	M	B	d	S	CATALOG NUMBER							
						L=36	L=46	L=56	L=76	L=96	L=116	L=136	L=156
24	15	9	9	14	7	SSP-24x36	SSP-24x46	SSP-24x56	SSP-24x76	SSP-24x96			
36	18	11	11	18	9		SSP-36x46	SSP-36x56	SSP-36x76	SSP-36x96	SSP-36x116	SSP-36x136	
									SSP-48x76	SSP-48x96	SSP-48x116	SSP-48x136	SSP-48x156

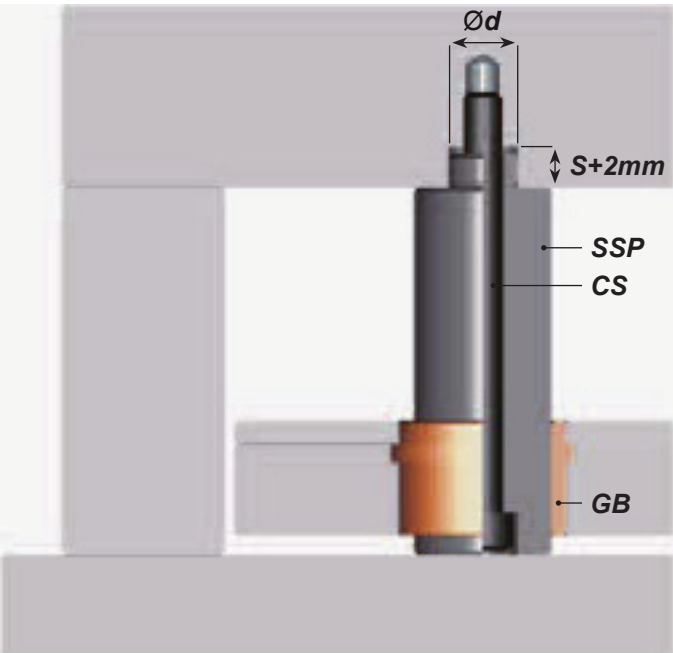

B	D	H	S	T	L	Part Number	
24	32	36	6	5	26	GB1000	GB5000
36	44	48	6	5	30	GB1001	GB5001
48	58	62	10	6	40	GB1002	GB5002

- > All 'SSP' guided ejection support pillars are case hardened to the same standards as DMS leader pins.
- > Assembly is suggested with metric capscrews (not supplied).
- > SSP24 series use M8 capscrew.
- > SSP36 series use M10 capscrew.
- > SSP48 series use M12 capscrew.

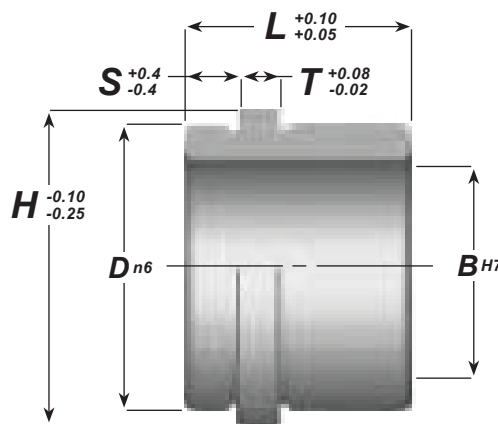

MATERIAL N22 CASE HARD

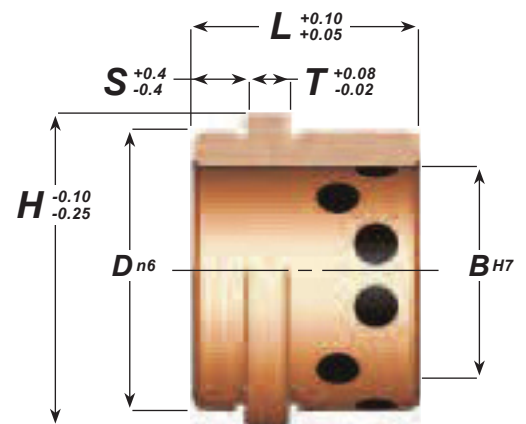

ALUMINUM, BRONZE & GRAPHITE PLUGS

# STANDARD SUPPORT PILLARS TAPPED

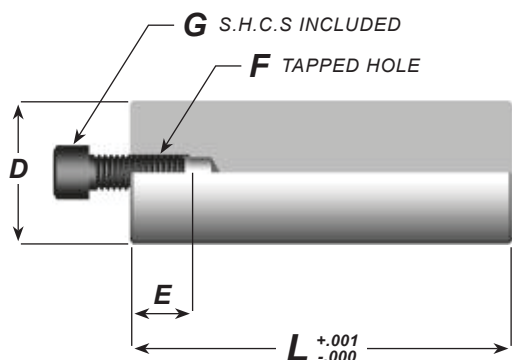

D	E	F	G	CATALOG NUMBER							
				L=2-1/2"	L=3"	L=3-1/2"	L=4"	L=4-1/2"	L=5"	L=6"	L=8"
1"	5/8	3/8-16	3/8-16x1"	SP1090	SP1091	SP1092	SP1093	SP1094			
1-1/4	5/8	3/8-16	3/8-16x1"	SP1130	SP1131	SP1132	SP1133	SP1134	SP1135	SP1136	
1-1/2	5/8	3/8-16	3/8-16x1"	SP1140	SP1141	SP1142	SP1143	SP1144	SP1145	SP1146	
2"	5/8	3/8-16	3/8-16x1"	SP1150	SP1151	SP1152	SP1153	SP1154	SP1155	SP1156	

# STOP PINS

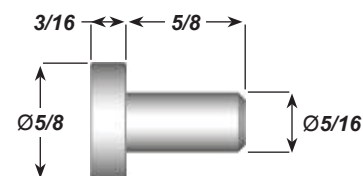
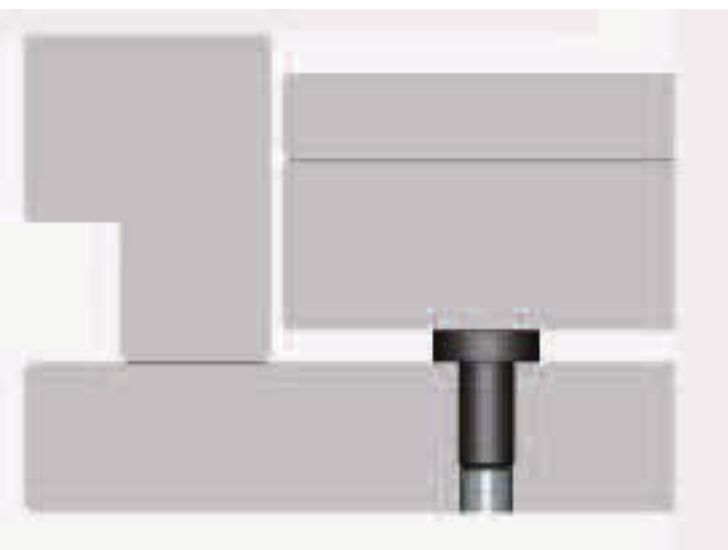

**Standard**

- > Head thickness is .020 oversize to provide grinding stock.
- > Catalog Number SB-001.

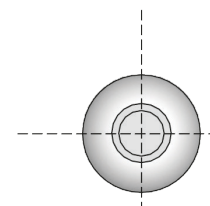
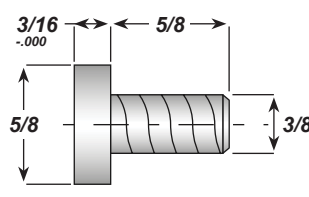

**Hardened & Self-Tapping**

- > Head thickness has grind stock.
- > Use with 11/32 drilled hole.
- > Catalog Number SB-001ST.

# SPRUE BUSHINGS

## B-SERIES

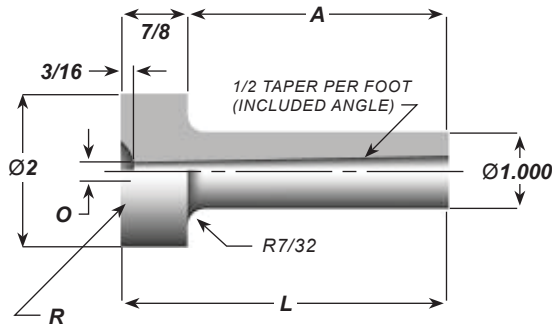

A	L	O=5/32		O=7/32		O=9/32		O=11/32	
		R=1/2	R=3/4	R=1/2	R=3/4	R=1/2	R=3/4	R=1/2	R=3/4
29/32	1-25/32	B129512	B129534	B129712	B129734	B129912	B129934	B129112	B129134
1-13/32	2-9/32	B221512	B221534	B221712	B221734	B221912	B221934	B221112	B221134
1-29/32	2-25/32	B229512	B229534	B229712	B229734	B229912	B229934	B229112	B229134
2-13/32	3-9/32	B321512	B321534	B321712	B321734	B321912	B321934	B321112	B321134
2-29/32	3-25/32	B329512	B329534	B329712	B329734	B329912	B329934	B329112	B329134
3-13/32	4-9/32	B421512	B421534	B421712	B421734	B421912	B421934	B421112	B421134
3-29/32	4-25/32	B429512	B429534	B429712	B429734	B429912	B429934	B429112	B429134
4-13/32	5-9/32	B521512	B521534	B521712	B521734	B521912	B521934	B521112	B521134
4-29/32	5-25/32	B529512	B529534	B529712	B529734	B529912	B529934	B529112	B529134
5-29/32	6-25-32			B629712	B629734	B629912	B629934	B629112	B629134
6-29/32	7-25-32			B729712	B729734	B729912	B729934	B729112	B729134

## A-SERIES

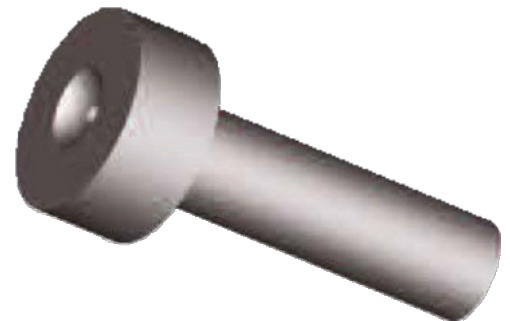
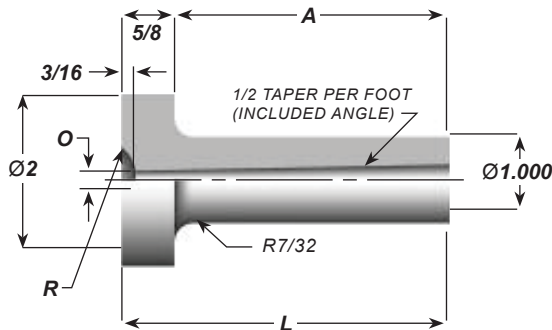

A	L	O=5/32		O=7/32		O=9/32		O=11/32	
		R=1/2	R=3/4	R=1/2	R=3/4	R=1/2	R=3/4	R=1/2	R=3/4
1-3/16	1-13/16	A129512	A129534	A129712	A129734	A129912	A129934	A129112	A129134
1-11/16	2-5/16	A221512	A221534	A221712	A221734	A221912	A221934	A221112	A221134
2-3/16	2-13/16	A229512	A229534	A229712	A229734	A229912	A229934	A229112	A229134
2-11/16	3-5/16	A321512	A321534	A321712	A321734	A321912	A321934	A321112	A321134
3-3/16	3-13/16	A329512	A329534	A329712	A329734	A329912	A329934	A329112	A329134
3-11/16	4-5/16	A421512	A421534	A421712	A421734	A421912	A421934	A421112	A421134
4-3/16	4-13/16	A429512	A429534	A429712	A429734	A429912	A429934	A429112	A429134

# SPRUE BUSHINGS

## U-SERIES

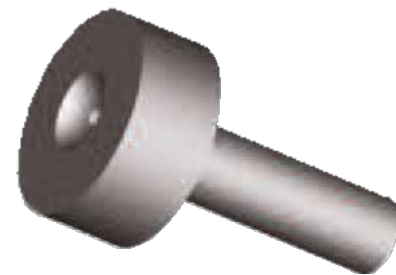
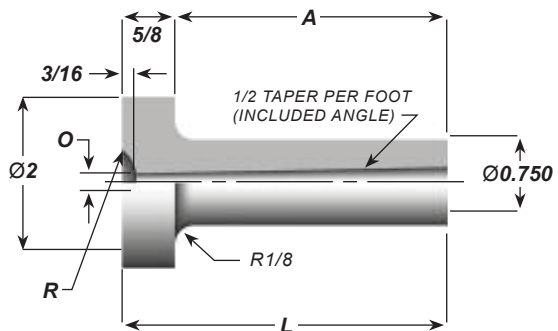

A	L	O=5/32		O=7/32		O=9/32	
		R=1/2	R=3/4	R=1/2	R=3/4	R=1/2	R=3/4
29/32	1-25/32	U157512	U157534	U157712	U157734	U157912	U157934
1-13/32	2-9/32	U241512	U241534	U241712	U241734	U241912	U241934
1-29/32	2-25/32	U257512	U257534	U257712	U257734	U257912	U257934
2-13/32	3-9/32	U341512	U341534	U341712	U341734	U341912	U341934
2-29/32	3-25/32	U357512	U357534	U357712	U357734	U357912	U357934
3-13/32	4-9/32	U428512	U428534	U428712	U428734	U428912	U428934
3-29/32	4-25/32	U478512	U478534	U478712	U478734	U478912	U478934

# SPRUE REAMERS

**MACHINE REAMER (ROUGHING)**



**HAND REAMER (FINISHING)**

HAND REAMERS						
Catalog Number	Flutes	Taper per foot	Diameter Small End	Diameter Large End	Shank Diameter	Flute Length
HR-50-06S	4	1/2	7/64	3/8	5/16	6"
HR-50-10L	6	1/2	13/64	5/8	1/2	10-1/2

MACHINE REAMERS						
Catalog Number	Flutes	Taper per foot	Diameter Small End	Diameter Large End	Shank Diameter	Flute Length
MR-50-06S	3	1/2	7/64	3/8	5/16	6"
MR-50-10L	3	1/2	13/64	5/8	1/2	10-1/2

# LOCATING RINGS

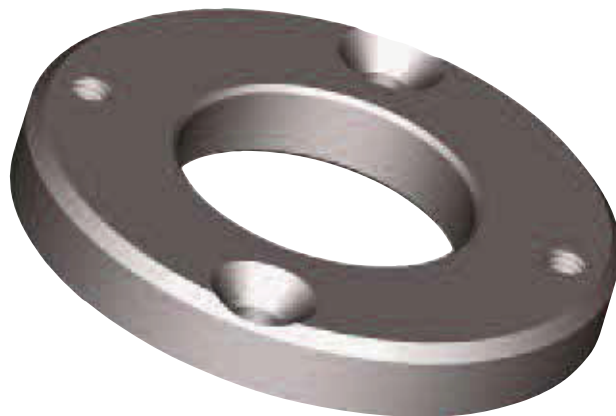

Catalog Number	D	Description
LR500	2.615	
LR501	3.990	Standard Series
LR501LN	3.990	LN Series
LR502	4.990	
LR503	2.000	
LR504	3.990	Clamp Type
LR505LN	5.990	LN Series
LR511	2.990	
LR520	3.990	Extension Nozzle Type
LR521	3.990	Standard Series - Extra Lead In
LR522	3.990	Extension Nozzle Type - Extra Lead In
LR524	3.990	Clamp Type - Extra Lead In
LR535	3.541	
LR536	4.331	Top Ring
LR537	4.331	Bottom Ring

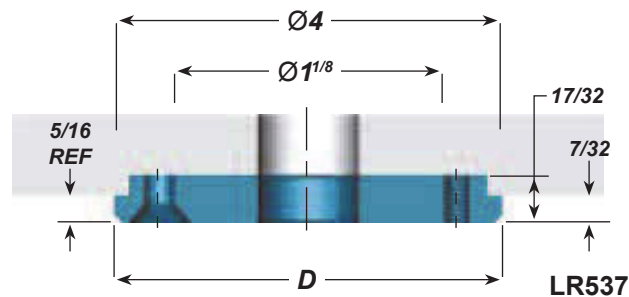
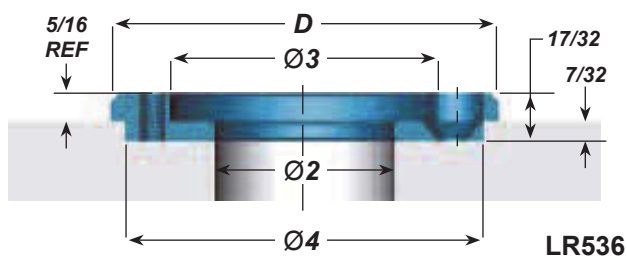
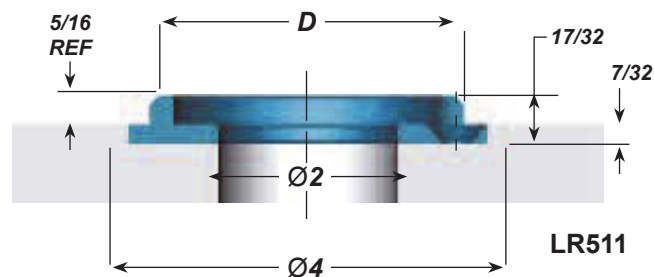
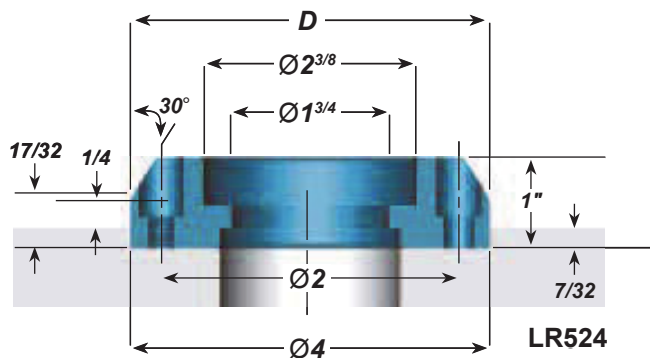
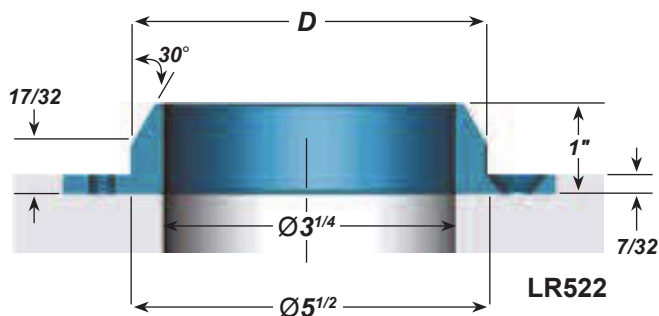

# LOCATING RINGS

- ▶ LR521 and LR524 are supplied with two 5/16-18 Socket Head Cap Screws.
- ▶ All other Locating Rings are supplied with two 5/16-18 Flat Head Screws.

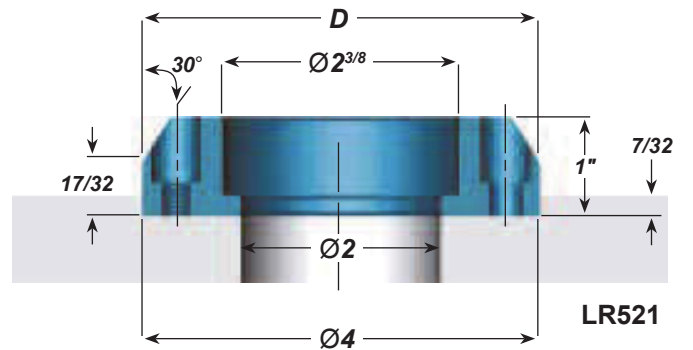
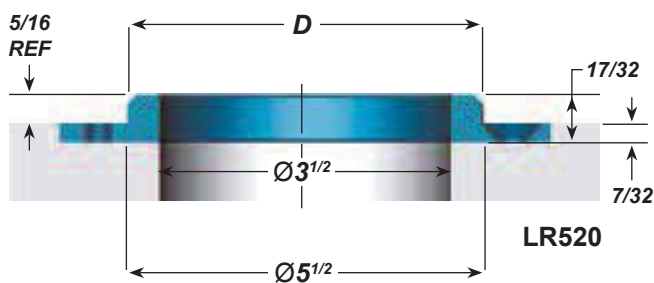
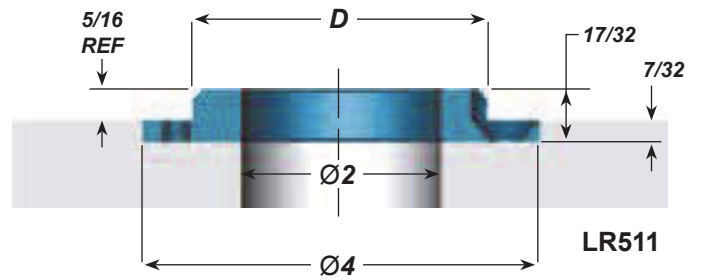
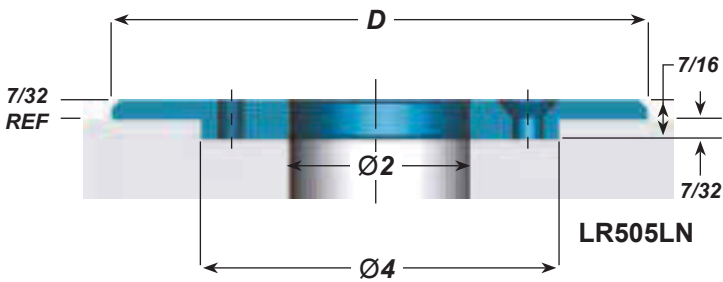
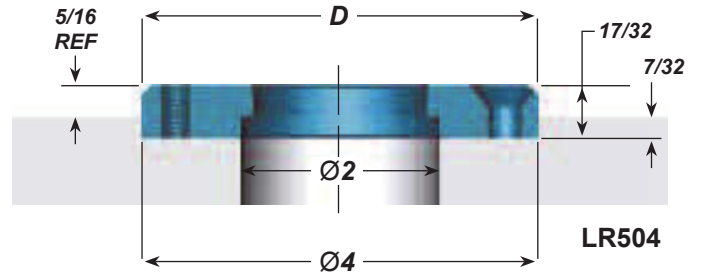
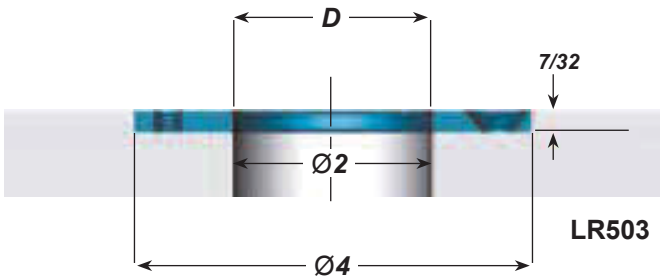
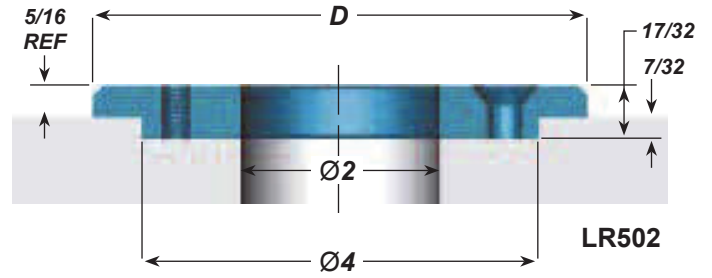
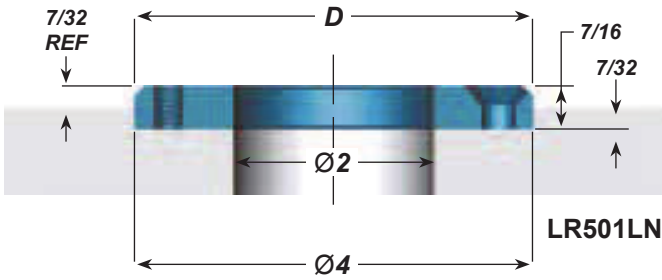
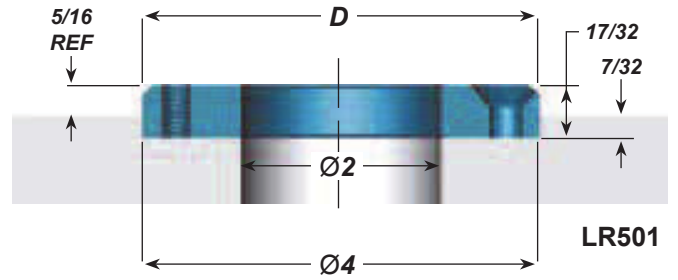
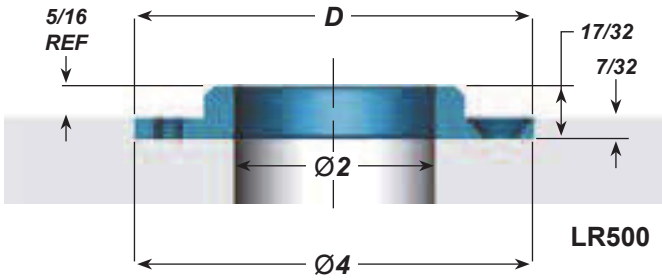

# ROUND TAPERED INTERLOCKS

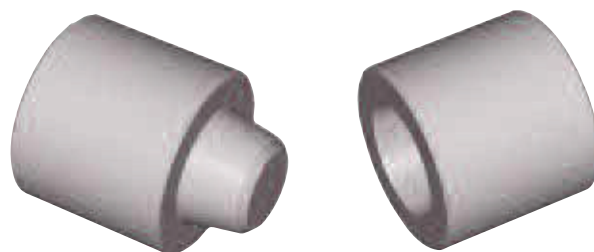
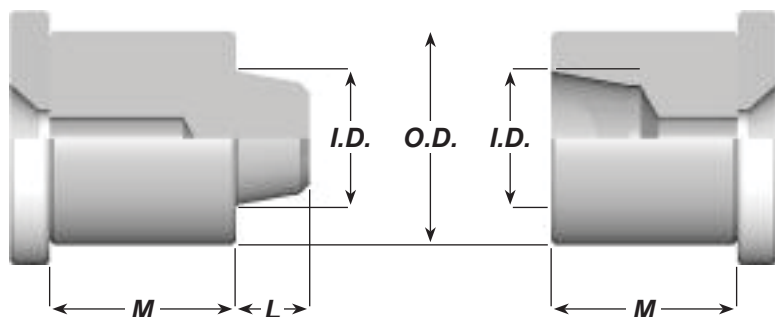

FEMALE				
O.D. +.0000 -.0005	I.D.	TAP SIZE	M +.010 +.015	Catalog Number
1/2	5/16	10-24	7/8	FTL050-14
			1-3/16	FTL050-19
			1-3/8	FTL050-22
			11/16	FTL075-11
3/4	1/2	1/4-20	7/8	FTL075-14
			1-3/16	FTL075-19
			1-3/8	FTL075-22
			11/16	FTL100-11
1"	5/8	1/4-20	7/8	FTL100-14
			1-3/16	FTL100-19
			1-3/8	FTL100-22
			1-1/8	FTL150-18
1-1/2	1"	5/16-18	1-3/8	FTL150-22
			1-5/8	FTL150-26
			1-1/8	FTL200-18
2"	1-1/2	5/16-18	1-3/8	FTL200-22
			1-5/8	FTL200-26

MALE					
O.D. +.0000 -.0005	I.D.	L	TAP SIZE	M +.010 +.015	Catalog Number
1/2	5/16	1/4	10-24	11/16	MTL050-11
				7/8	MTL050-14
				1-3/16	MTL050-19
				1-3/8	MTL050-22
3/4	1/2	9/32	1/4-20	11/16	MTL075-11
				7/8	MTL075-14
				1-3/16	MTL075-19
				1-3/8	MTL075-22
1"	5/8	11/32	1/4-20	11/16	MTL100-11
				7/8	MTL100-14
				1-3/16	MTL100-19
				1-3/8	MTL100-22
1-1/2	1"	1/2	5/16-18	1-1/8	MTL150-18
				1-3/8	MTL150-22
				1-5/8	MTL150-26
2"	1-1/2	1/2	5/16-18	1-1/8	MTL200-18
				1-3/8	MTL200-22
				1-5/8	MTL200-26

- ▶ DMS round tapered interlocks provide positive alignment of cavities and cores.
- ▶ Extra grind stock is provided at the back of both male and female for positive fitting.

# STOP & SPACER COMPONENTS

- > Spacer/ Stop Plates
- > Return Pin Stop Spacer
- > Switch Dogs/ Rods
- > Stop Buttons



## Spacer & Stop Plates

Part #	O.D.	Thickness	Screw Size
SP050	11/16"	3/16"	10-24
SP075	1"	3/16"	1/4-20
SP0100	1-3/16"	3/16"	1/4-20
SP0150	1-11/16"	1/4"	1/4-20
SP200	2-3/16"	1/4"	5/16-18
SD07	1"	3/16"	10-24
SD0750	3/4"	3/16"	10-24
SD-10	1-3/16"	3/16"	10-24



\*Used as rest buttons or spacers

**NOTE:** Other sizes available upon request.

## Stop Spacers

Part #	O.D.	Thickness	Screw Size
SS-15	1-3/16"	1/2"	1/4-20
SS-20	1-11/16"	1/2"	1/4-20
SDB15375	1-1/2"	3/4"	3/8-16



**NOTE:** Other sizes available upon request.

## Switch Dog Stops

Part #	O.D.	Thickness	Thread
SSD8070	2"	.62"	1/2-20



**NOTE:** Other sizes available upon request.



**NOTE:** 1/2-20 Threaded rod cut to length available upon request.

# TAPER BAR LOCKS

- ▶ DMS Tapered Bar Locks provide positive alignment between mold halves.
- ▶ They maintain alignment while allowing for thermal expansion.
- ▶ Made of 1045 steel hardened to 58-60 HRc.
- ▶ Male and Female mounting pockets should be accurately aligned, flat and parallel to the parting line.
- ▶ The pocket lengths should be long enough to provide clearance.

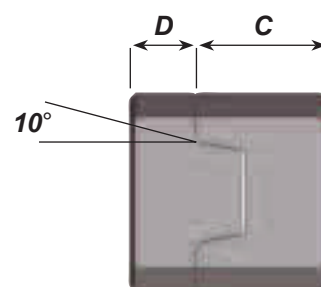
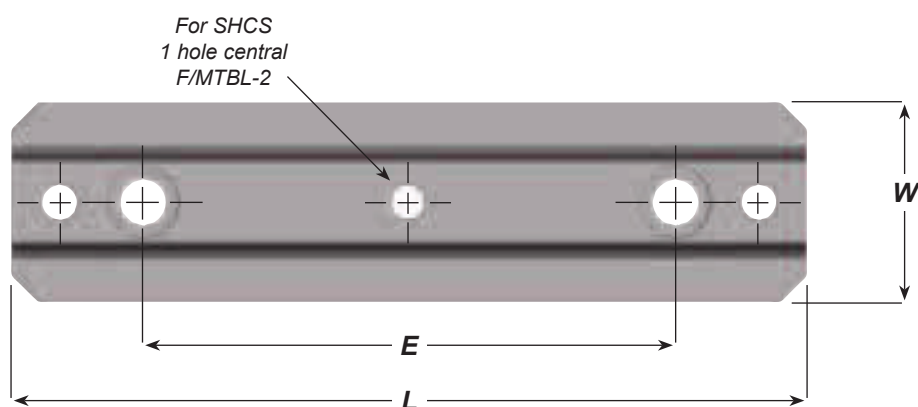

## SOLD ONLY IN SETS\*\*

SET CODE	Number	L +0.010 -0.010	W +0.000 -0.001	D +0.005 -0.005	E +0.005 -0.005	S.H.C.S.	Jackscrew Thread
MFTBL-2	MTBL-2	1.980	0.999	0.312	-	#10-24	#10-24
MFTBL-4	MTBL-4	3.980	1.249	0.375	2.500	1/4-20	1/4-20
MFTBL-6	MTBL-6	5.980	1.499	0.500	4.000	5/16-18	5/16-18

SET CODE	Number	L +0.010 -0.010	W +0.000 -0.001	C +0.005 -0.005	E +0.005 -0.005	S.H.C.S.	Jackscrew Thread
MFTBL-2	FTBL-2	1.980	0.999	0.690	-	#10-24	#10-24
MFTBL-4	FTBL-4	3.980	1.249	0.870	2.500	1/4-20	1/4-20
MFTBL-6	FTBL-6	5.980	1.499	1.000	4.000	5/16-18	5/16-18

- ▶ When ordering, use SET CODE
- ▶ Example: MFTBL-2 (Supplied with MTBL-2 & FTBL-2)



# SIDE LOCKS

- > Male half: O-6 steel (58-60 Rc)
- > Black Oxide Finish
- > Female half: S-7 steel (54-56 Rc)
- > Titanium Nitrided (80 Rc)
- > Supplied with socket head cap screws.
- > Sold in sets only.

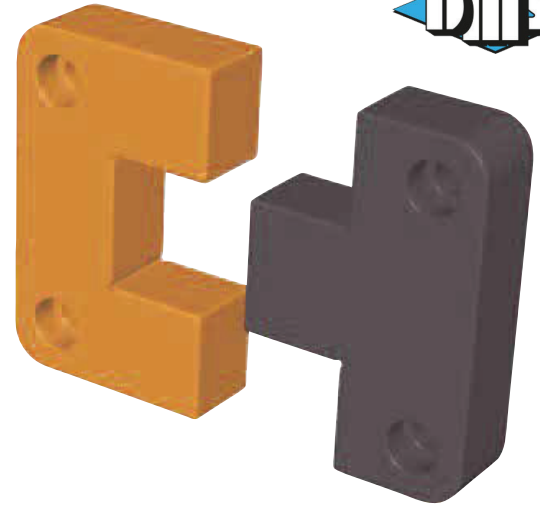

Catalog Number	A +.0000 -.0004	B +.000 -.002	C +.000 -.002	D +.000 -.002	E	F .0001/.0002 Clearance per side	G +.010 -.010	R	SHCS
PLS-100	1.000	0.870	1.125	0.375	1.310	0.440	0.250	3/16	10-32 X 1/2
PLS-125	1.250	0.870	0.875	0.437	1.230	0.500	0.250	1/4	10-32 X 1/2
PLS-150	1.500	0.870	1.000	0.500	1.250	0.625	0.281	1/4	10-32 X 5/8
PLS-200	2.000	0.870	1.375	0.620	1.375	0.680	0.375	1/4	1/4-20 X 3/4
PLS-300	3.000	1.120	1.875	0.745	2.000	1.125	0.440	5/16	1/4-20 X 7/8
PLS-400	4.000	1.370	1.875	0.875	2.312	1.375	0.625	3/8	3/8-16 X 1
PLS-500	5.000	1.370	2.375	1.120	2.625	1.750	0.625	3/8	3/8-16 X 1-1/4

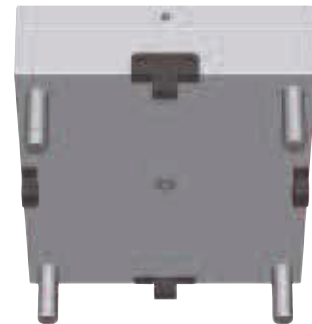
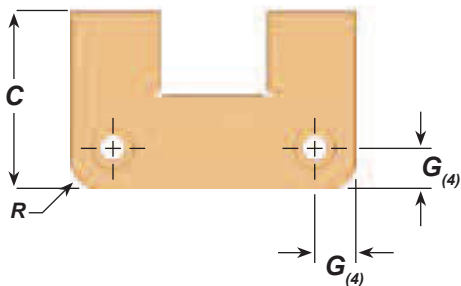
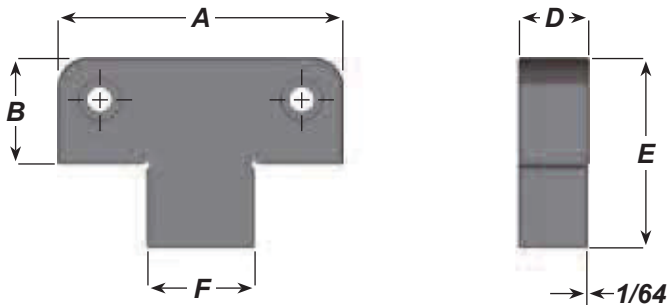

**NOTE:** Metric sizes available.

# TOP LOCKS

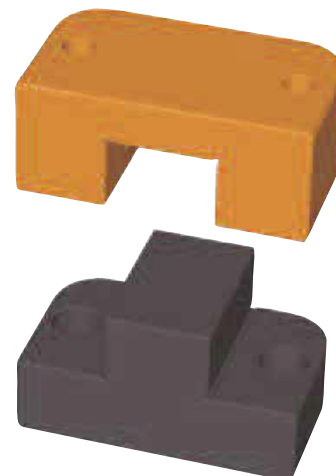

- > Male half: O-6 steel (58-60 Rc)
- > Black Oxide Finish
- > Female half: S-7 steel (54-56 Rc)
- > Titanium Nitrided (80 Rc)
- > Supplied with socket head cap screws.
- > Sold in sets only.

Catalog Number	A +.0000 -.0004	D +.000 -.002	C +.000 -.002	B +.000 -.002	E +.010 -.010	F .0001/.0003 Clearance per side	G1 +.010 -.010	G2 +.010 -.010	R	SHCS	
										MALE	FEMALE
TL50X100	1.000	0.500	0.500	0.375	0.300	0.375	0.25	0.688	0.188	#6-32 X 1/2	#6-32 X 5/8
TL62X125	1.250	0.625	0.625	0.500	0.410	0.438	0.312	0.875	1/4	#6-32 X 5/8	#6-32 X 3/4
TL75X125	1.250	0.750	0.625	0.500	0.380	0.438	0.375	0.875	1/4	#8-32 X 5/8	#8-32 X 3/4
TL87X150	1.500	0.875	0.875	0.750	0.570	0.500	0.437	1.000	1/4	#8-32 x 7/8	#8-32 x 1
TL100X150	1.500	1.000	0.875	0.375	0.570	0.500	0.500	1.000	1/4	#10-32 X 1/2	#10-32 X 1
TL100X200	2.000	1.000	1.125	0.750	0.750	0.750	0.500	1.375	3/8	#10-32 x 7/8	#10-32 x 1-1/8
TL112X200	2.000	1.125	0.875	0.625	0.500	0.750	0.563	1.375	3/8	1/4-20 X 3/4	1/4-20 X 1
TL112X300	3.000	1.125	1.500	0.750	0.870	1.125	0.563	2.250	1/2	1/4-20 X 7/8	1/4-20 X 1-5/8
TL150X250	2.500	1.500	1.375	0.625	0.850	1.000	0.750	1.750	3/8	1/4-20 X 3/4	1/4-20 X 1-1/2
TL175X300	3.000	1.750	1.250	0.875	0.750	1.125	0.875	2.250	1/2	5/16-18 X 1	5/16-18 X 1-1/4
TL200X350	3.500	2.000	1.750	0.750	1.07	1.500	1.000	2.500	1/2	3/8-16 X 7/8	3/8-16 X 2

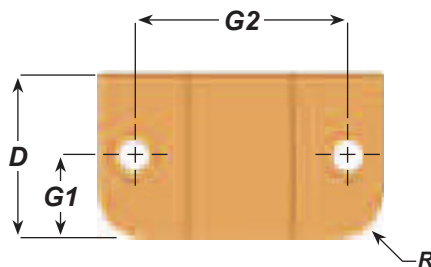
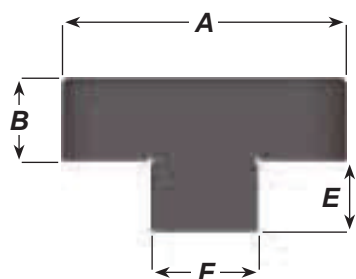

# GUIDE LOCKS

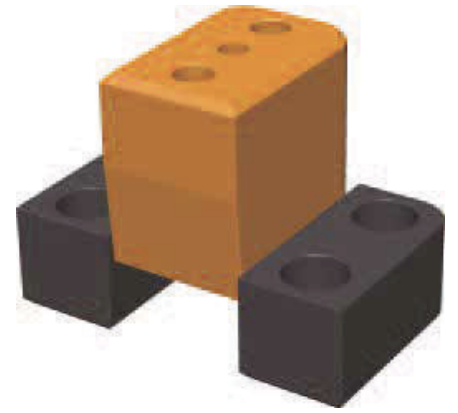
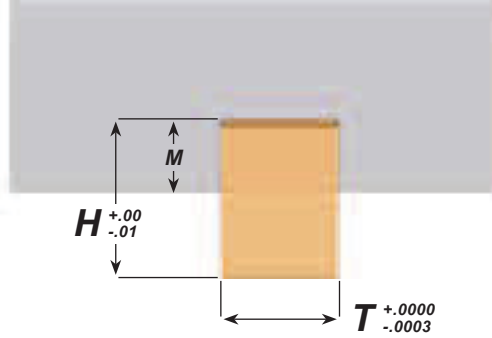
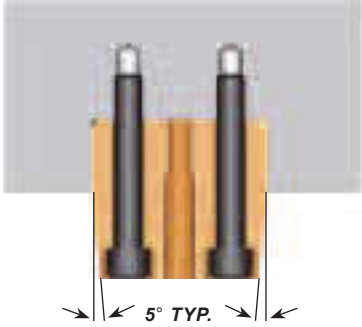

## INSTALLATION NOTES

Because Guide Locks can be used inside the mold as well as at the parting line, DMS has added a jack screw hole to the male interlock.

This allows removal without damage to the mold. Also added is a 5° angle on each end of the male.

### Male:

- AISI D2 (58-60 Rc)
- Titanium Nitride Coated
- 78-80 Rc

### Female:

- AISI 1045 (60-62 Rc)
- Black Oxide Finish

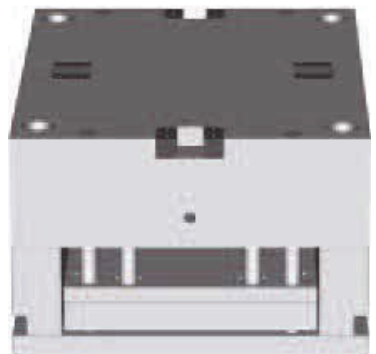
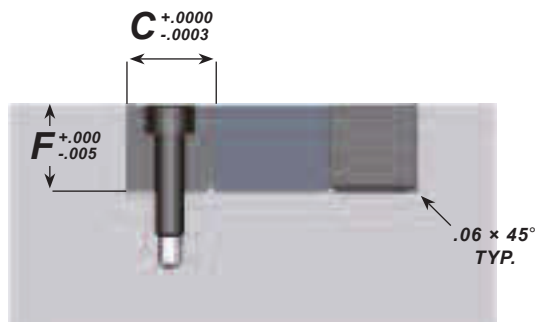
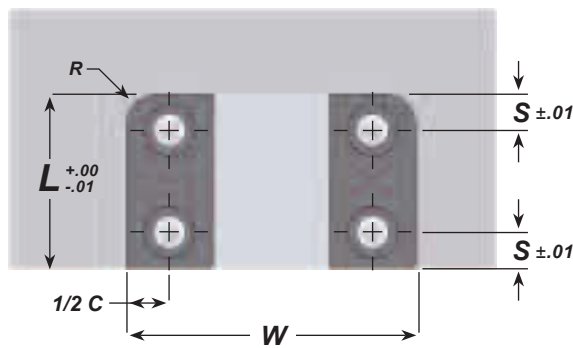
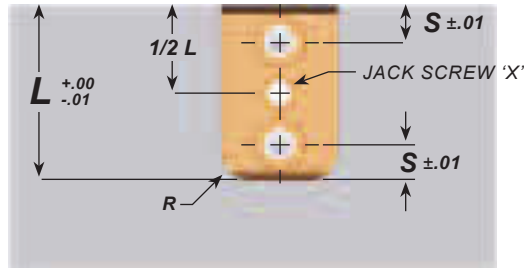

Cat No.	W +.000 -.010	L +.000 -.010	T +.0000 -.0003	H +.000 -.010	M	C +.0000 -.0003	F +.000 -.005	S +.010 -.010	R	X Jack Screw	SHCS	
											MALE (2)	FEMALE (4)
GL-1.5	1.500	1.000	0.500	0.850	0.375	0.500	0.500	0.250	0.187	#6-32	#10-32 X 1"	#10-32 X 5/8
GL-2.5	2.500	1.500	1.000	1.350	0.625	0.750	0.750	0.310	0.250	1/4-20	1/4-20 X 1-1/2	1/4-20 X 7/8
GL-3.5	3.500	2.000	1.500	1.730	0.750	1.000	1.000	0.440	0.375	3/8-16	3/8-16 X 2"	3/8-16 X 1-1/4
GL-4.5	4.500	2.500	2.000	2.100	0.875	1.250	1.250	0.560	0.500	3/8-16	1/2-13 X 2-1/4	1/2-13 X 1-1/2

# E SIDE LOCKS

**Male half:** AISI O2

52-56 Rc

**Female half:** AISI O2

56-58 Rc

- Supplied with socket head cap screws.
- Sold in sets only.

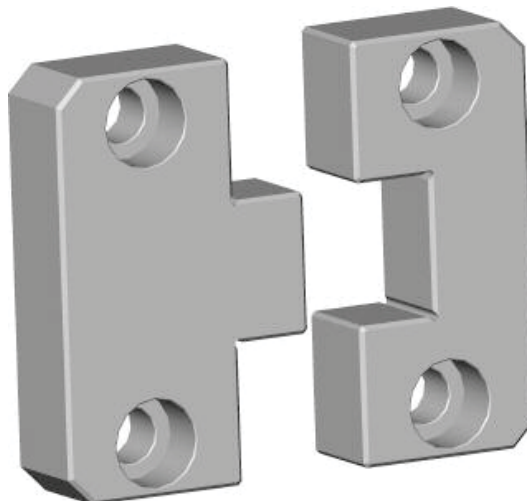

Catalog Number	A +.0000 -.0004	B +.0000 -.0008	C +.0000 -.0008	D +.000 -.002	E	F	G +.010 -.010	H	J	K	L	SHCS
ESL-1.5	1.500	0.870	0.870	0.620	1.180	0.500	0.281	0.281	0.437	0.281	0.190	1/4-20 X 3/4
ESL-2.0	2.000	0.870	0.870	0.620	1.180	0.680	0.375	0.375	0.437	0.375	0.190	1/4-20 X 3/4
ESL-3.0	3.000	1.360	1.370	0.745	1.910	1.000	0.688	0.375	0.688	0.375	0.190	3/8-16 X 1"
ESL-4.0	4.000	1.870	1.870	0.745	2.640	1.375	0.875	0.625	0.875	0.625	0.500	3/8-16 X 1"
ESL-5.0	5.000	1.870	1.870	1.120	2.640	1.750	0.875	0.750	0.875	0.750	0.500	1/2-13 X 1-1/4

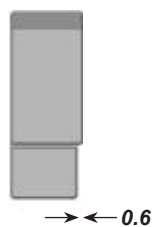
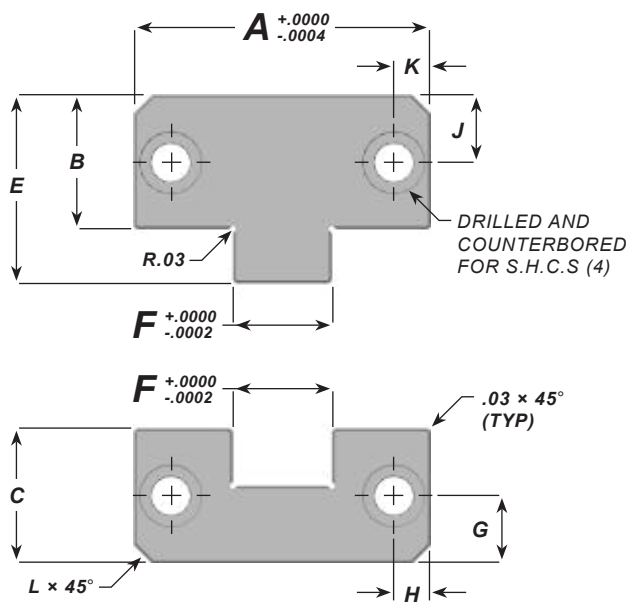



# E SIDE LOCKS

TREATED

Male half: YK 30 (58 ±2 Hrc)

Black Oxide Finish

Female half: A2 Core 58-60 Surface (80 ±2 Hrc)

Titanium Nitride Coated

➤ Supplied with socket head cap screws.

➤ Sold in sets only.

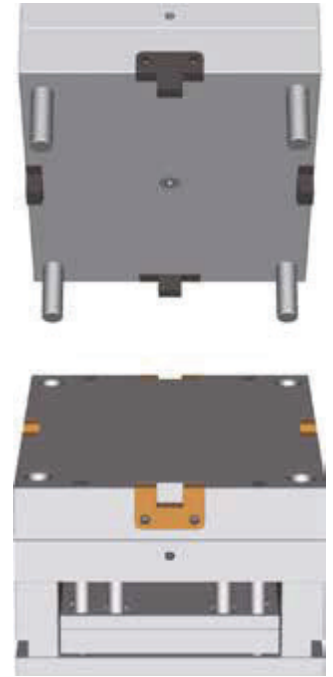
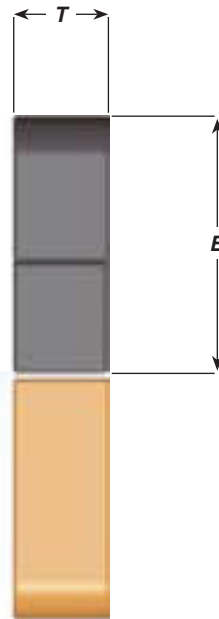
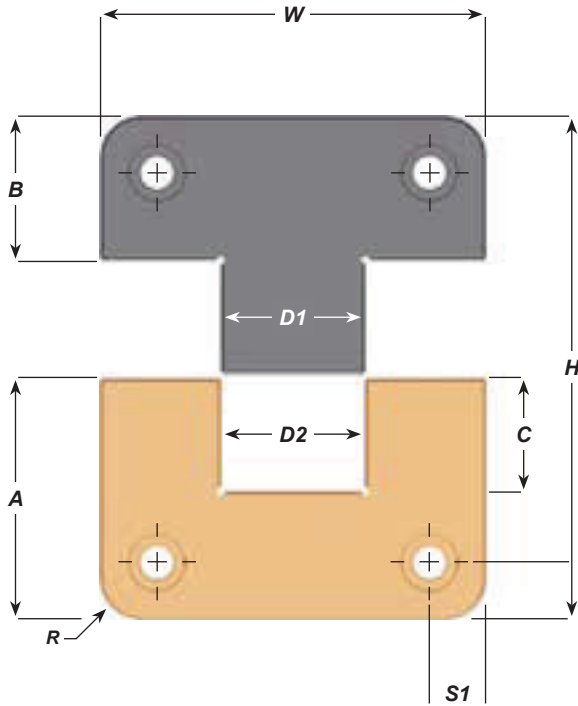
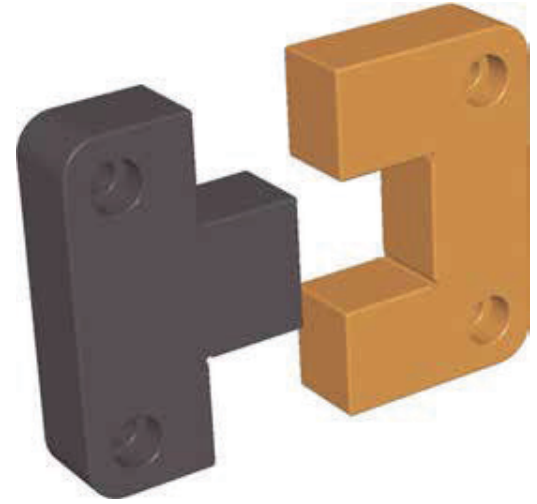

Catalog Number	W +.0000 -.0004	T +.000 -.002	A +.000 -.002	B +.000 +.002	C	D1 +.0000 -.0002	D2 +.0002 -.0000	H +.002 -.004	R	S1/S2 +.01 -.01	SHCS
ESLT-100	1.000	0.375	1.125	0.875	0.530	0.500	0.500	2.000	0.187	0.250	10-32x 1/2
ESLT-125	1.250	0.490	1.125	0.875	0.660	0.500	0.500	2.000	0.187	0.250	8/32 x 5/8
ESLT-150	1.500	0.500	0.875	0.875	0.560	0.563	0.563	1.750	0.187	0.250	8/32 x 5/8
ESLT-200	2.000	0.500	1.375	0.875	0.660	0.750	0.750	2.250	0.187	0.312	10-32 x 1/2
ESLT-300	3.000	0.750	1.875	0.875	1.130	1.250	1.250	2.750	0.250	0.375	1/4-20 x 3/4
ESLT-400	4.000	1.000	2.375	1.375	1.250	1.500	1.500	3.750	0.500	0.500	3/8-16 x 1
ESLT-500	5.000	1.250	2.875	1.375	1.630	2.000	2.000	4.250	0.500	0.625	1/2-13 x 1-1/4
ESLT-600	6.000	1.500	2.875	1.375	1.750	2.500	2.500	4.250	0.500	0.625	1/2-13 x 1-1/2

# GIB ASSEMBLIES

- Gib Assemblies are supplied assembled with (2) L-Gibs, (1) Base Plate, (4) 1/4" Dowels and (1) Slide.
- Each item can also be ordered separately.
- Assemblies come pre-doweled and pre-drilled with clearance holes for 5/16" screw.
- Slide unit is P20 steel, HRC 20-28.
- Base and L-Gibs are Aluminum Bronze material.

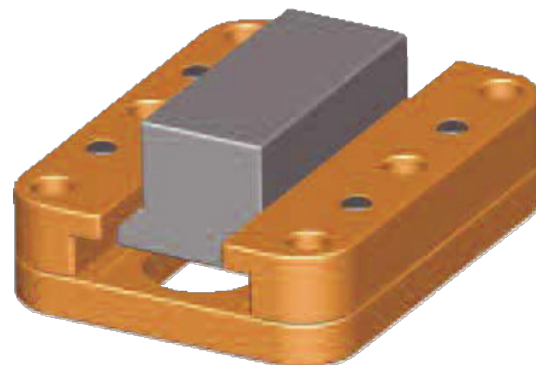

Catalog Number				A	B	L
Assembly	Slide	Base	L-Gib			
GA35	GAS25	GAB35	GAL35	-	3.125	3.50
GA40	GAS25	GAB40	GAL40	2.00	3.625	4.00
GA45	GAS25	GAB45	GAL45	2.25	4.125	4.50

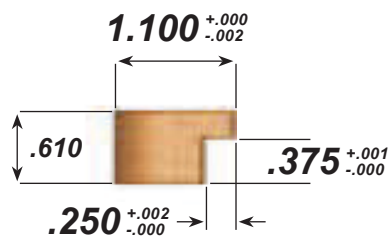
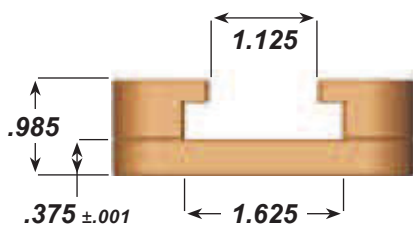
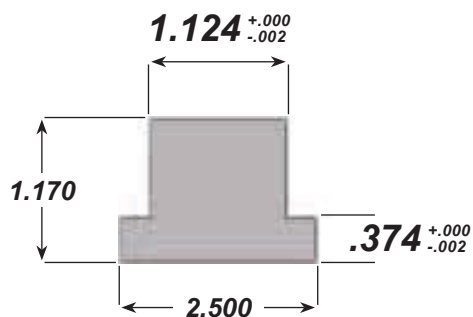
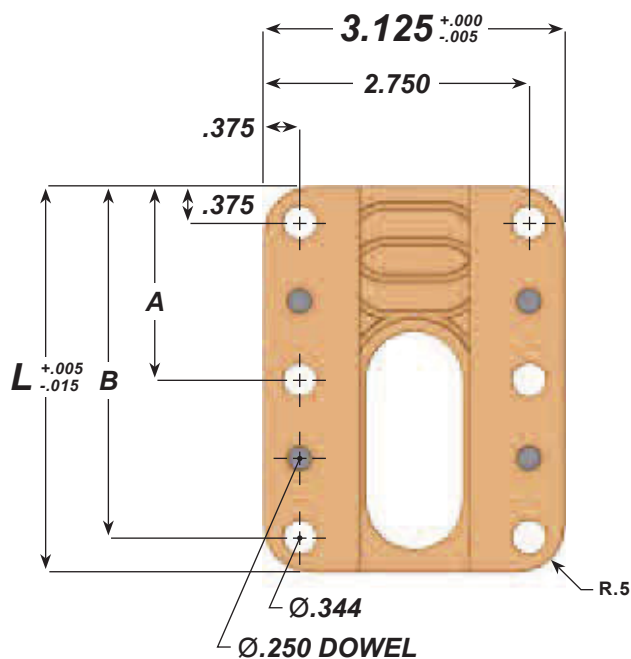

# SLIDE RETAINERS

INCH

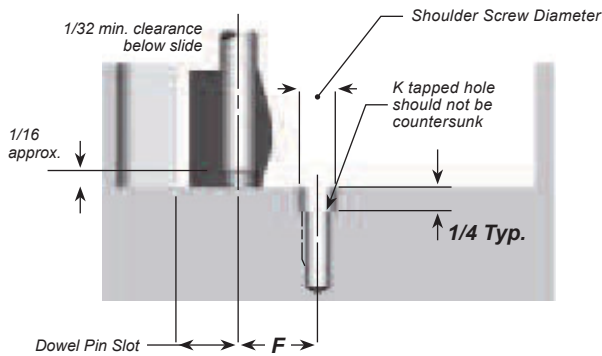
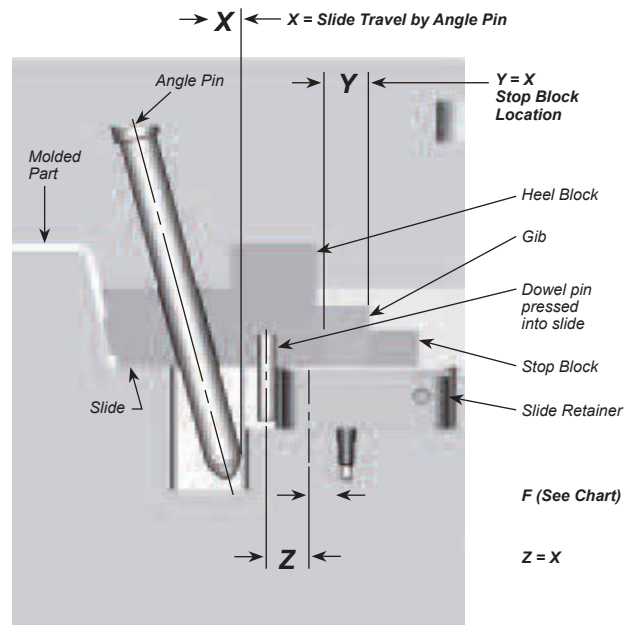
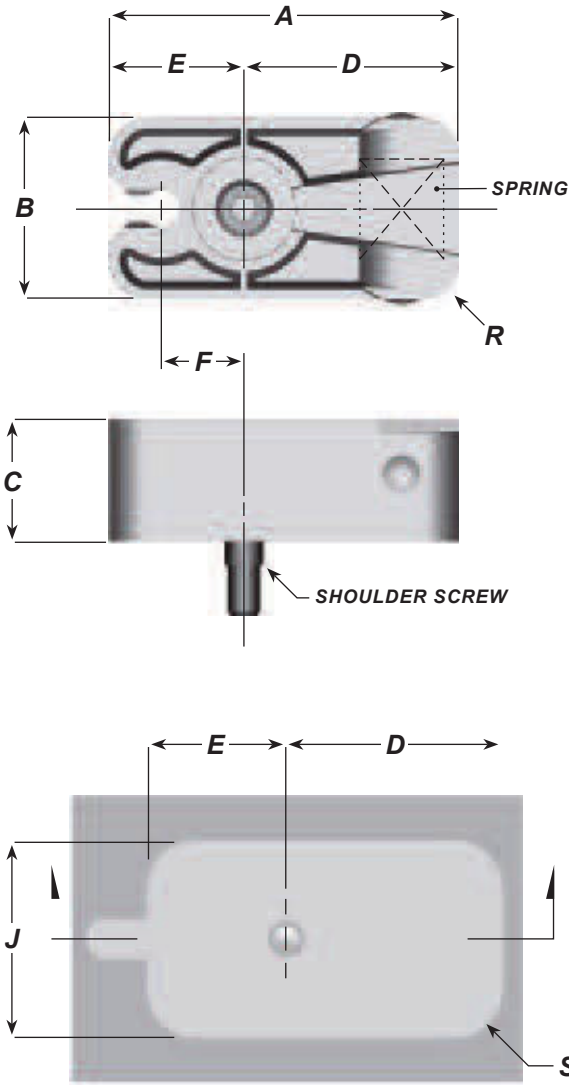

- ▶ A compact method of slide retention that eliminates the use of springs or costly hydraulic systems.
- ▶ Interference with machine tie bars or safety gates is eliminated because the slide retainer can be installed behind or below the slide.
- ▶ They can be used in multiples for larger or heavier slides.

Catalog Number	A	B	C	D	E	F	R	Dowel Pin	Maximum Slide Weight	G	H	J	Tapped Hole K	Shoulder Screw	S
SRP-22	1-1/2	3/4	0.63	0.89	0.61	0.360	0.19	1/4 X 1-1/4	22 Pounds	0.73	1.01	1.00	10-24 X 1/2	1/4 X 5/8	0.31
SRP-44	2-1/8	1-1/4	0.79	1.31	0.81	0.500	0.25	5/16 X 1-1/2	44 Pounds	0.93	1.43	1.50	1/4-20 X 1/2	5/16 X 3/4	0.37
SRP-88	3-3/8	1-3/4	1.18	2.08	1.30	0.800	0.38	3/8 X 2-1/4	88 Pounds	1.42	2.20	2.20	5/16-18 X 5/8	3/8 X 1"	0.50

# SLIDE RETAINERS

## METRIC

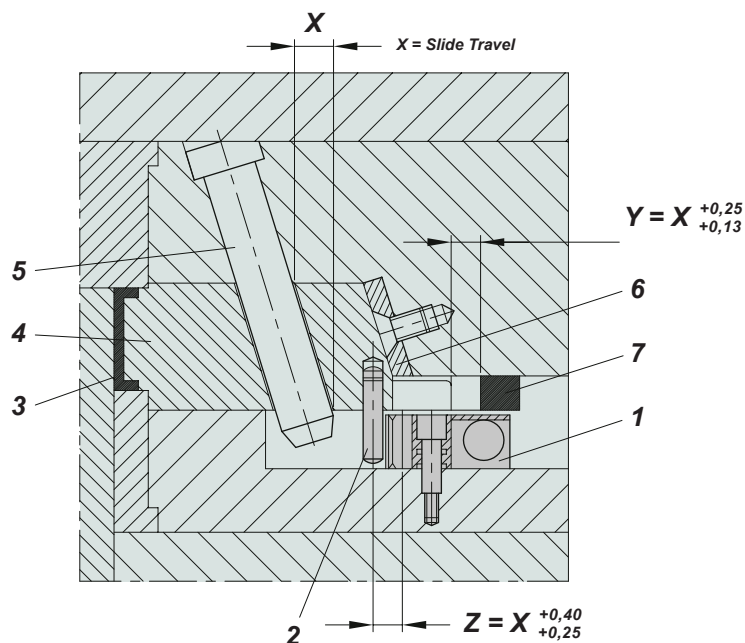

REF	Slide Retainer							RETAINER POCKETS IN MOLD										MAX. SLIDE WEIGHT (KG)
	A	B	C	D	E	F*	S	G	H	I	J	K	L	M	N	P	R	
MRT-10M	38	19	16	22	16	9,1	5	19	26	25	17	8	6	M5	6	6	15,5	10
MRT-20M	54	32	20	33	21	12,7	6	24	36	38	21	10	8	M6	8	8,5	20,5	20
MRT-40M	86	45	30	53	33	20,3	10	36	56	51	31	12	11	M8	10	10	25,0	40

The distance from the center of the dowel pin to the center of the stripper bolt is critical.

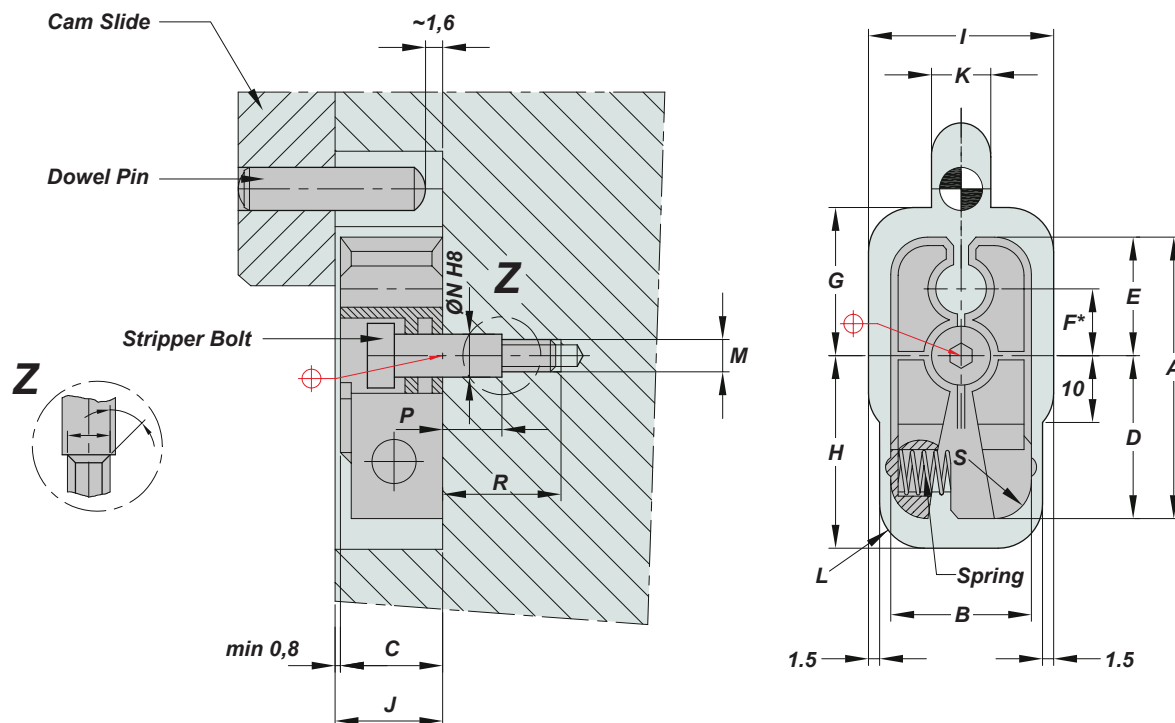

# MINIATURE SLIDE RETAINERS

Catalog Number	Ø K	Ø L	Ø M	N DIM
SPSR 1000	0.625	0.869	0.94	0.670
SPSR 2000	0.750	0.987	1.06	0.715
SPSR 4000	0.875	1.105	1.19	0.763

**NOTE:** .500 thick wear plate can also be used to key and retain Mini-Might slide retainer instead of retaining key. Mold maker to machine to suit.

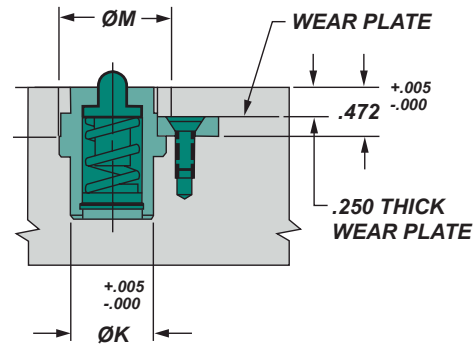
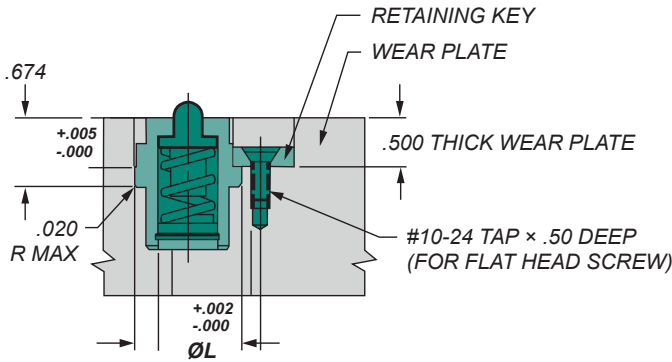
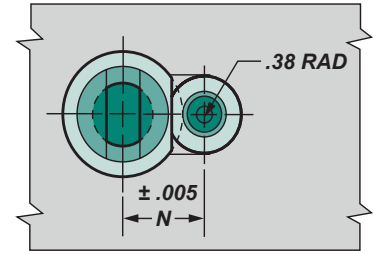

**NOTE:** Use .028 thick spacer under retaining key when mold has been machined for .500 thick wear plate. Mold maker to machine to suit.

## Typical Application of Miniature Slide Retainers

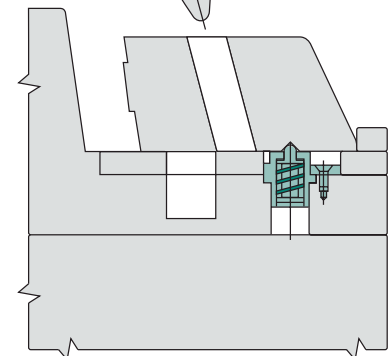
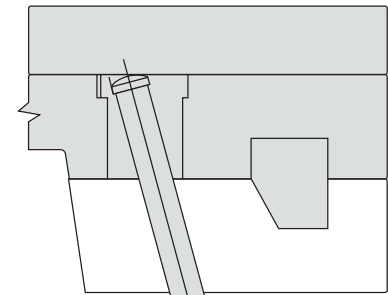
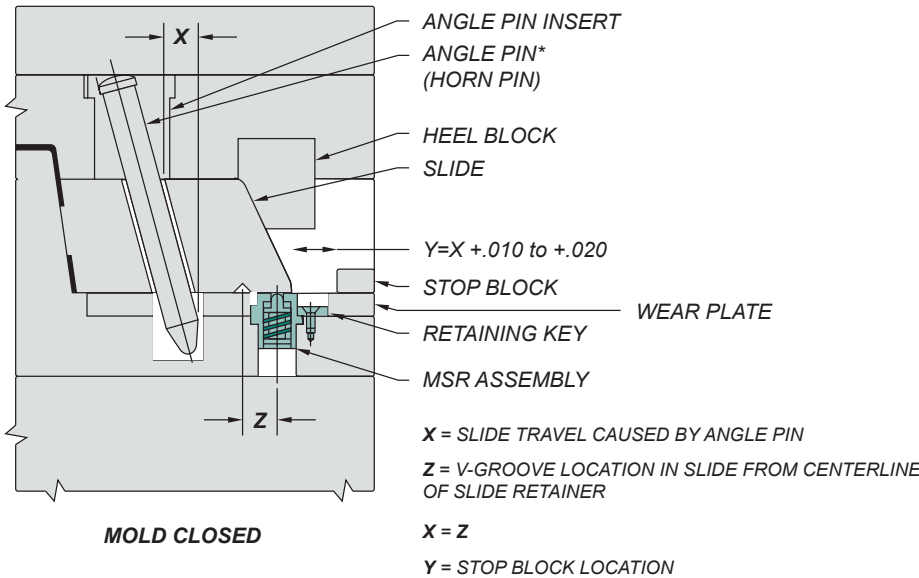

**MOLD OPEN**

**NOTES:**

- Lubricate all metal-to-metal contact areas before first use and every 100,000 cycles (or more frequently as required.) Use a good grade of moldmakers' non-melting type grease rated for the operating temperature to be encountered.
- Replace compression spring every 1,000,000 cycles or as required.
- Do not operate at temperatures exceeding 250°F.

# MINIATURE SLIDE RETAINERS



(U.S. Patent No. 5,397,226)

- Three sizes with slide ratings for 22, 44, and 88 lbs.
- Small in size, yet strong holding capacity.
- Self-contained product design facilitates easy installation.
- Slide can be removed without removing the slide retainer from the mould.

## Installation Dimensions for Machining V-Groove in Slide

Catalog Number	V-Groove Depth
SPSR 1000	0.091
SPSR 2000	0.153
SPSR 4000	0.194

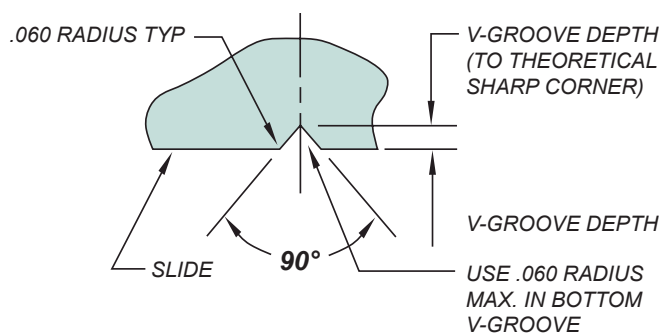

## Dimensional Information for Miniature Slide Retainers

Material: Hardened H-13 Steel (Body and Plunger)

Catalog Number	A	B	C	ØD	ØE	F Flat	ØH	J PLUNGER
SPSR 1000	1.08	0.072	0.795	0.620	0.630	0.375	0.866	0.188
SPSR 2000	1.32	0.121	1.035	0.740	0.748	0.420	0.984	0.250
SPSR 4000	1.26	0.149	0.975	0.870	0.866	0.468	1.102	0.312

Catalog Number	MAXIMUM RECOMMENDED HOLDING WEIGHT
SPSR 1000	10 POUNDS
SPSR 2000	20 POUNDS
SPSR 4000	40 POUNDS

† Each includes: slide retainer assembly, retaining key, and #10-24 x .50 long flat head screw. Replacement parts are special order.

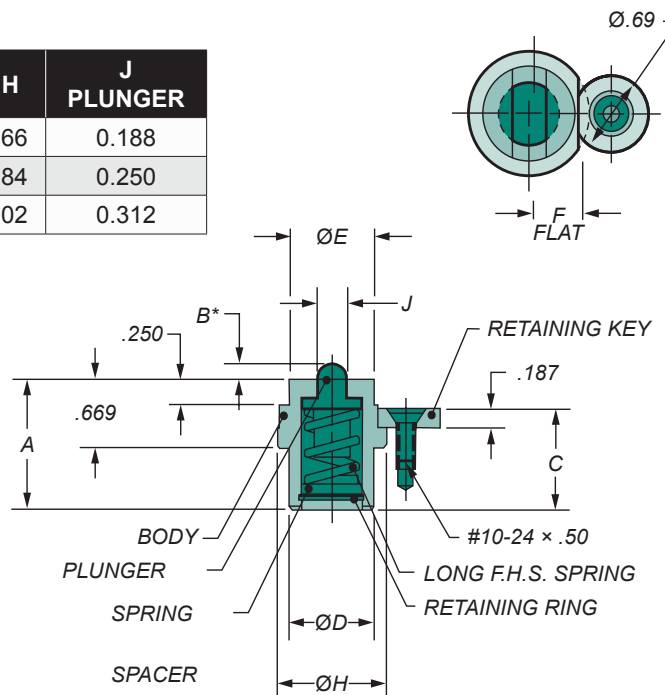

\*V-groove in slide will compress plunger approx. .01 to .03.

NOTE: See "Pocket Dimensions" for additional information.

# SLIDE RETAINERS

## RECTANGULAR INCH

- ▶ Three sizes with slide ratings for 22, 44, and 88 lbs.
- ▶ Small in size, yet strong holding capacity.
- ▶ Provides a compact and economical means of slide retention.
- ▶ Suitable for new tooling design or retrofitting existing molds.
- ▶ Can be used in single or multiple configuration for heavier slides.



(U.S. Patent No. 4,961,702)

## RECTANGULAR Slide Retainer – PPSL

**Material:** Investment Cast steel

**Hardness:** Case-Hardened 58-62 HRC

Catalog Number	A	B	C	D	E	F*	N	P	S	T	L
PPSL 0001	1.50	0.76	0.63	0.27	1.23	0.980	0.94	0.61	0.14	0.250	1.25
PPSL 0002	2.13	1.26	0.79	0.44	1.69	1.375	1.44	0.88	0.25	0.312	1.50
PPSL 0003	3.38	1.76	1.18	0.75	2.63	2.125	1.94	1.57	0.38	0.375	2.25

Catalog Number	MAXIMUM RECOMMENDED SLIDE HOLD WEIGHT
PPSL 0001	22 POUNDS
PPSL 0002	44 POUNDS
PPSL 0003	88 POUNDS

\* Dimension F, the distance from dowel pin centerline at end of slide travel and centerline of shoulder screw, is important.

Overtravel of dowel pin beyond pin clearance provided at back of jaw area could result in damage to retainer.

† Includes compression spring, shoulder screw and dowel pin.

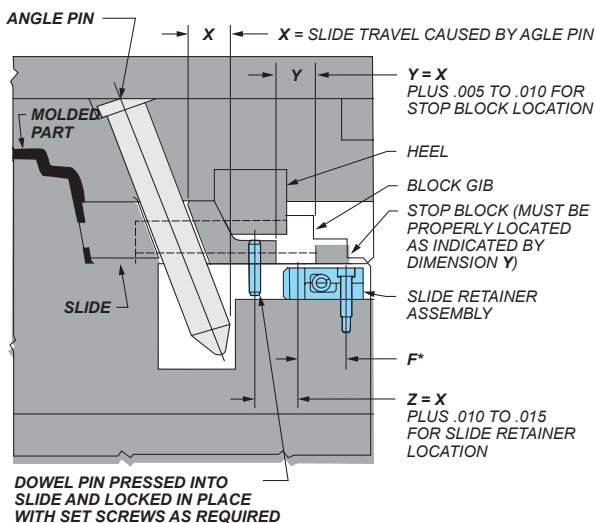
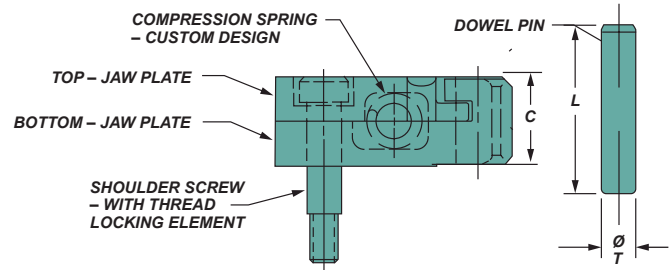
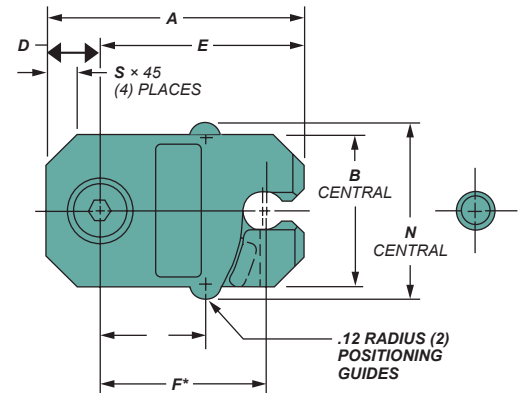

## RECTANGULAR Slide Retainer – PPSL Application

The PPSL is designed to be mounted behind and below the slide (see drawing left), and is a compact unit that can be entirely contained within the mold. Interference with tie bars or safety gates is no longer a problem. (It can even be installed completely underneath the slide if space is limited.)

As the mold opens, the dowel pin installed in the slide positively locks into the PPSL until disengaged by the mold's closing action. The spring placed crossway in the retainer maintains the force required to keep the dowel pin in the jaws when the mold is open.

The PPSL is designed with a lead-in at the jaw opening so the dowel pin will enter the jaws even if there is a slight misalignment between the retainer and the pin.

**NOTE:** To prevent the dowel pin from contacting and applying pressure against the back of the retainer jaw (which could cause shearing of the dowel pin or shoulder screw) the installation dimensions shown on these pages are recommended.

# SLIDE RETAINERS

PPSM

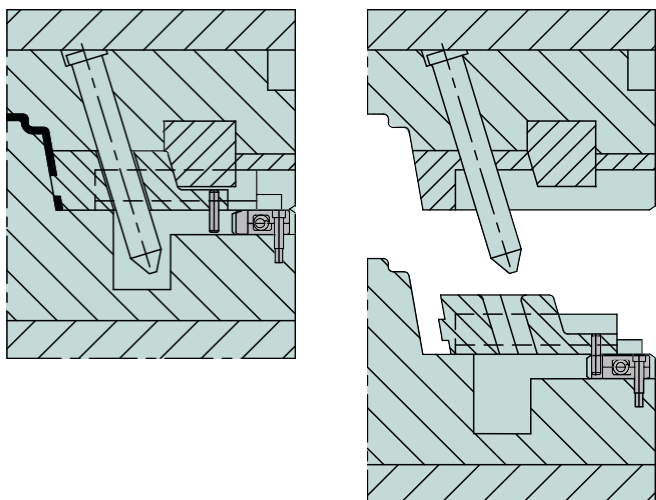

REF	CAM SLIDE									RETAINER POCKETS IN MOULD									Max. slide weight (kg)
	A	B	C	D	E	F*	G	H	I	J	K	L	M	N	O	P	Q	R	
PPSM 0001	38	19	16	7	31,5	24,89	24,0	15,5	25,5	17,5	8	10,0	34,5	8	8,5	6	20	M5	10
PPSM 0002	54	32	20	11	43,0	34,93	36,5	22,5	38,0	21,5	10	14,5	46,0	10	10,5	8	25	M6	20
PPSM 0003	86	45	30	19	67,0	53,98	49,5	40,0	51,0	31,5	12	22,5	70,0	12	17,0	10	35	M8	40

► The distance from the center of the dowel pin to the center of the stripper bolts is critical.

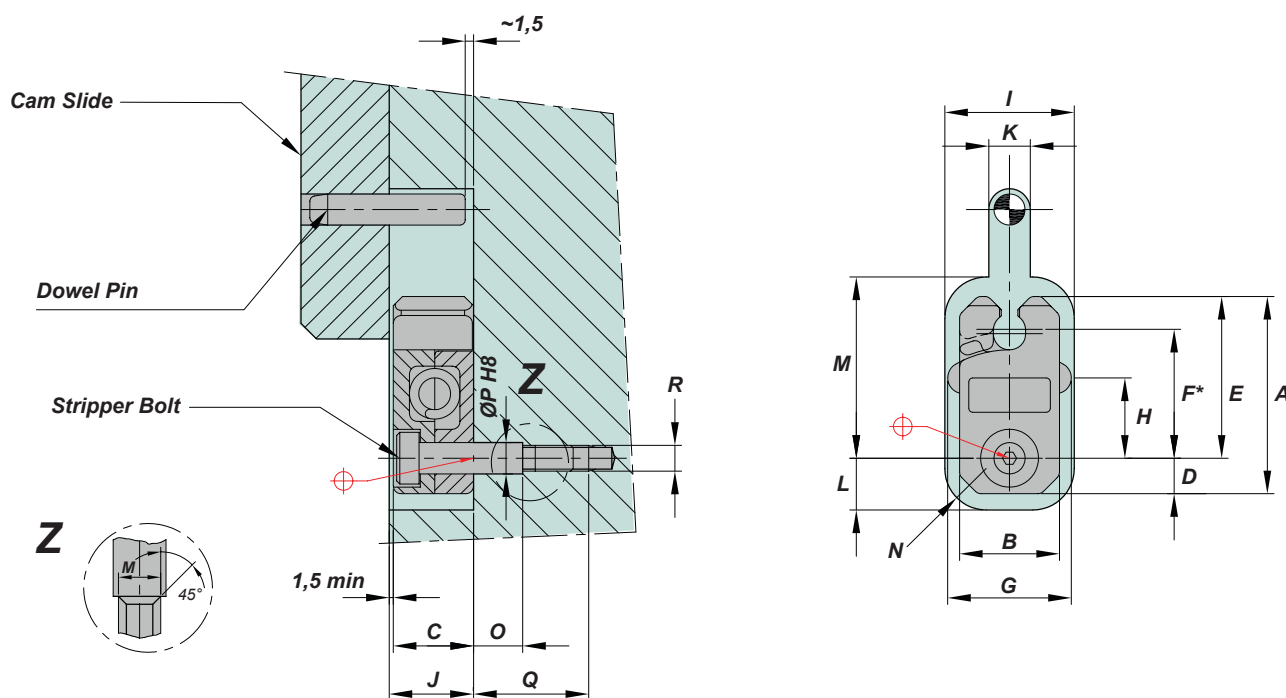

# SLIDE LATCH

## HIGH HARDNESS

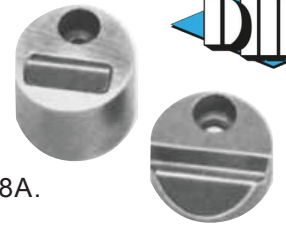

**SLK-8-HH** Rated to carry a weight up to 8 pounds. 100% interchangeable with SLK-8A.

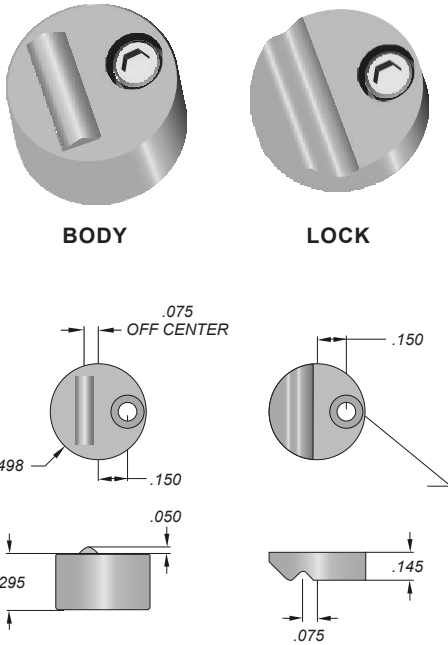

### INSTALLATION – LOCK

**OPTION A**  
MACHINED INTO SLIDE

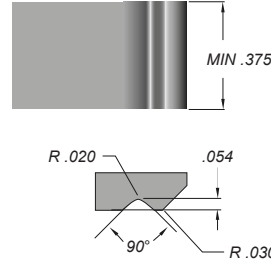

**OPTION B**  
LOCK INSERT

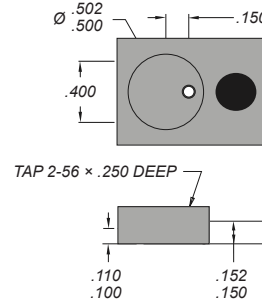

### DESIGN GUIDELINES

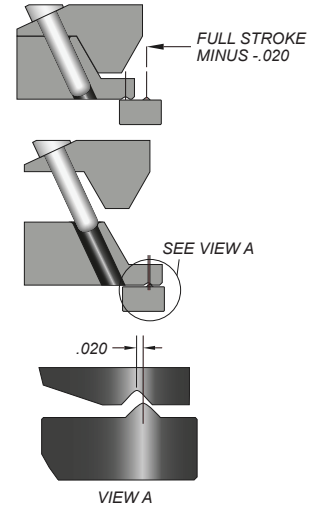

**NOTE:** Set angle pin to release .020 from full stroke. Striker will snap to full stroke to assure re-entry clearance of angle pin.

### INSTALLATION – BODY

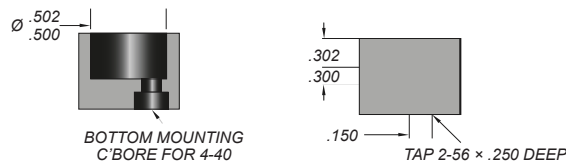

**SLK-25-HH** Rated to carry a weight up to 25 pounds. 100% interchangeable with SLK-25A.

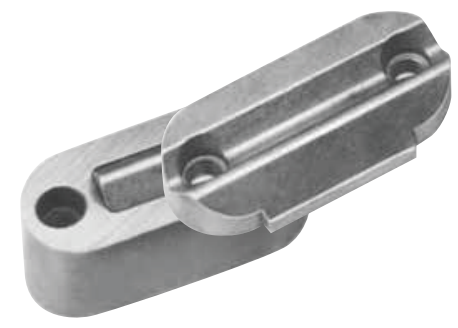
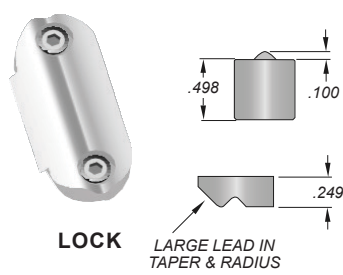
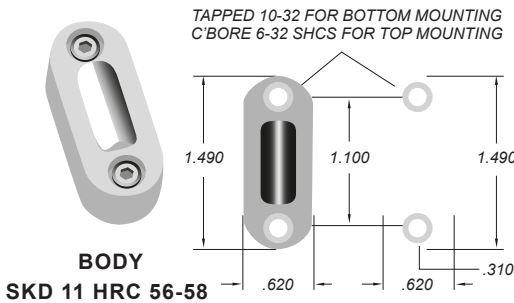

### INSTALLATION – LOCK

**OPTION A**  
MACHINED INTO SLIDE

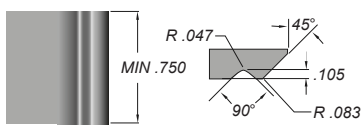

**OPTION B**  
LOCK INSERT

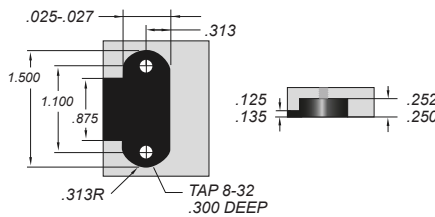

### DESIGN GUIDELINES

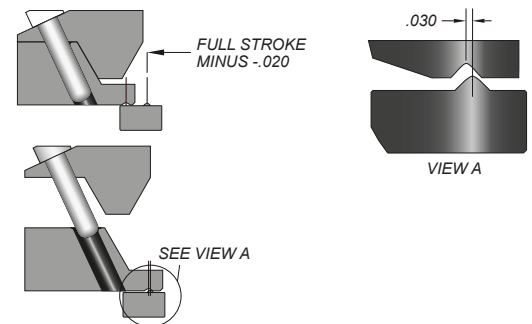

**NOTE:** Set angle pin to release .020 from full stroke. Striker will snap to full stroke to assure re-entry clearance of angle pin.

### INSTALLATION – BODY





# SLIDE LATCH

## MACHINING DATA

Slide-Latch model SLK-50HH is rated to carry a weight of up to 50 pounds. Ideal for die cast mold slide applications. Multiple Slide-Latches can be easily machined and mounted in mold slides for higher load retentions.



### SLK-50HH

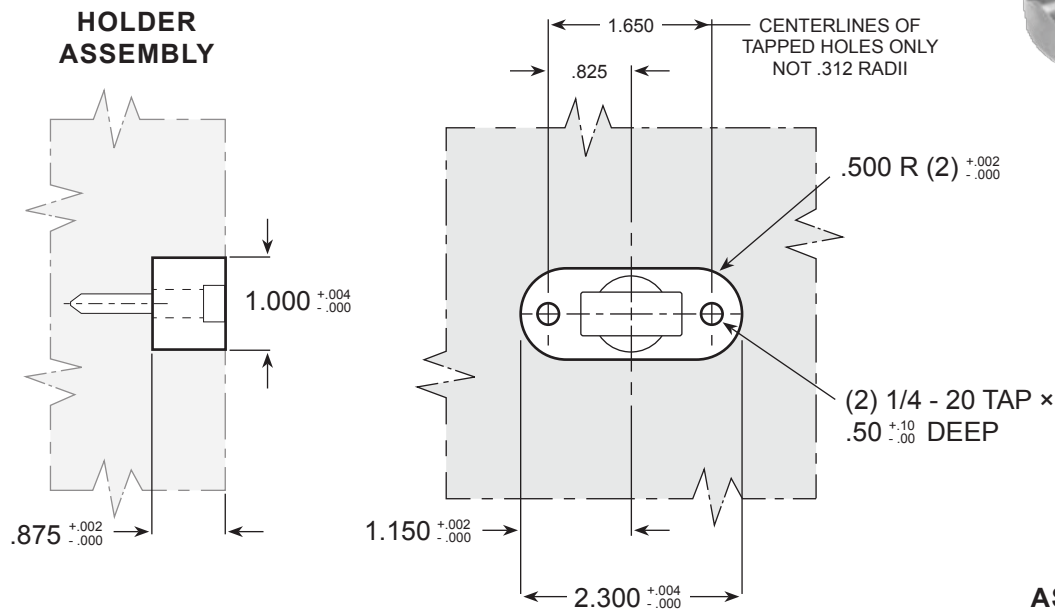

**ASSEMBLY REFERENCE**

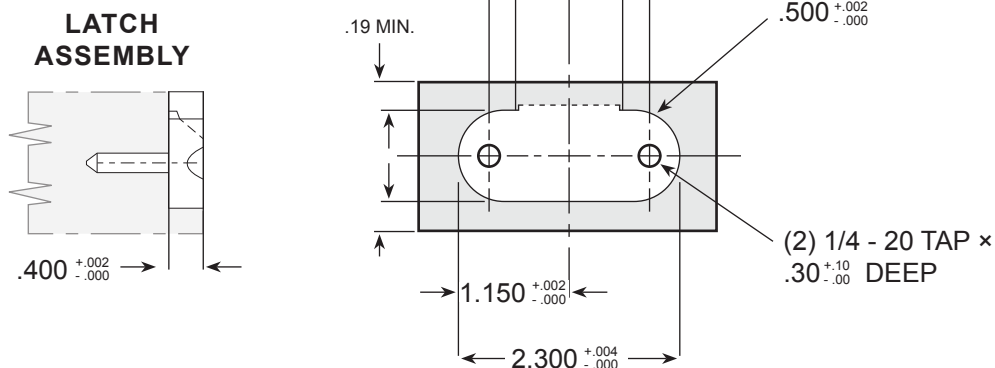
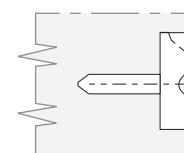
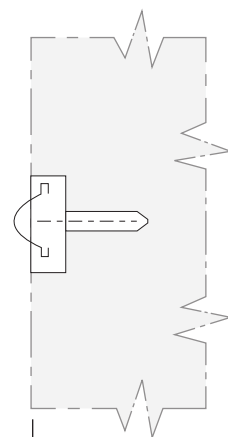

The latch is usually mounted into the slide because of normal space limitations and requirements. This is not a rule though, and the designer may locate the various components to best suit the application.

# ANGLE PINS

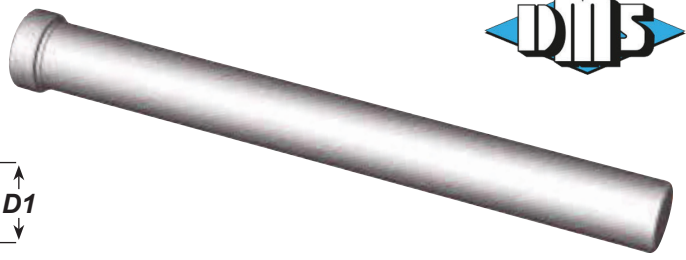
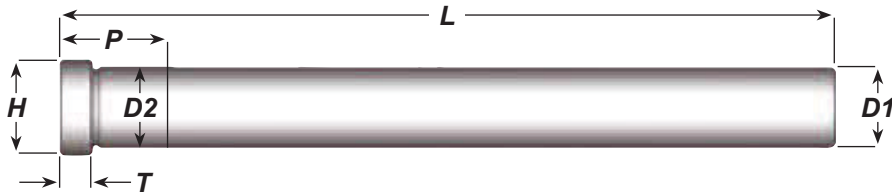

Catalog Number	Diameter	L		PFL	
		+ .12 - .00	+ .000 - .062	+ .000 - .062	+ .000 - .062
AP37L06	3/8	6"	7/8	7/8	7/8
AP37L10	3/8	10"	1-3/8	1-3/8	1-3/8
AP50L06	1/2	6"	7/8	7/8	7/8
AP50L10	1/2	10"	1-3/8	1-3/8	1-3/8
AP62L06	5/8	6"	7/8	7/8	7/8
AP62L10	5/8	10"	1-3/8	1-3/8	1-3/8
AP75L10	3/4	10"	1-3/8	1-3/8	1-3/8

Nominal Diameter	D1 + .0000 - .0005	D2 + .0005 - .0000	H + .000 - .010	T + .000 - .005
3/8	0.374	0.376	0.49	0.25
1/2	0.499	0.501	0.61	0.25
5/8	0.624	0.626	0.74	0.25
3/4	0.749	0.751	0.86	0.25

- ▶ Manufactured from H-13 steel.
- ▶ Core hardness 35-40 Rc.
- ▶ Surface hardness 65-75 Rc.
- ▶ Ground, nitrided and polished.

# ANGLE PINS WITH RADIUSED HEADS

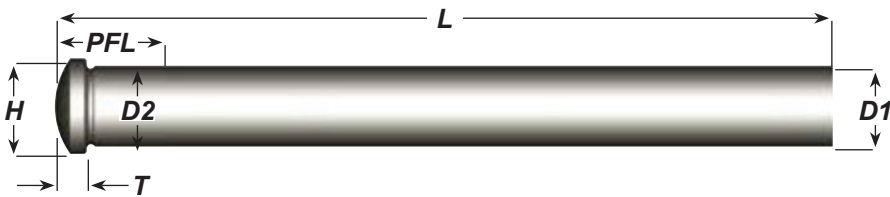

Catalog Number	Diameter + .0000 - .0005	L + .50 - .00	H + .000 - .010	T + .000 - .005	D2 + .0000 - .0005	PFL + .00 - .06	R SPH RAD
RAP37L06	0.374	6"	0.500	0.250	0.377	7/8	0.375
RAP37L10	0.374	10"	0.500	0.250	0.377	1-3/8	0.375
RAP50L06	0.499	6"	0.625	0.250	0.502	7/8	0.500
RAP50L10	0.499	10"	0.625	0.250	0.502	1-3/8	0.500
RAP62L06	0.624	6"	0.750	0.250	0.627	7/8	0.625
RAP62L10	0.624	10"	0.750	0.250	0.627	1-3/8	0.625
RAP75L10	0.749	10"	0.875	0.312	0.752	1-3/8	0.750
RAP75L14	0.749	14"	0.875	0.312	0.752	1-3/8	0.750
RAP100L10	0.999	10"	1.125	0.312	1.002	1-3/8	1.00
RAP100L14	0.999	14"	1.125	0.312	1.002	1-3/8	1.00

- ▶ Manufactured from H-13 steel.
- ▶ Core hardness 35-40 Rc.
- ▶ Surface hardness 65-75 Rc.
- ▶ Ground, nitrided and polished.

These pins are supplied with a spherical radius premachined on the head, which eliminates angle grinding usually required on the head. To install on a specific angle, use the chart to determine counterbore depth.

## INSTALLATION NOTES

Cut angle pin to length as required to obtain required travel on the slide. The angle pin works on angle in clearance hole in slide to push the slide and create travel.

## TYPICAL INSTALLATION

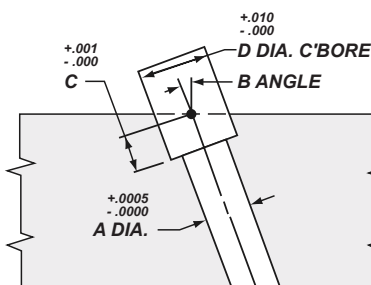

## Machining Dimensions for Installation

Pin "A" Diameter	Angle	C'bore Depth "C"	C'bore Dia. "D"
.377	10°	0.256	0.562
	15°	0.264	0.562
	20°	0.275	0.562
	25°	0.291	0.562
.502	10°	0.258	0.688
	15°	0.268	0.688
	20°	0.283	0.688
	25°	0.304	0.688
.627	10°	0.260	0.812
	15°	0.273	0.812
	20°	0.291	0.812
	25°	0.316	0.812
.752	10°	0.324	0.938
	15°	0.339	0.938
	20°	0.361	0.938
	25°	0.389	0.938
1.015	10°	0.328	1.188
	15°	0.348	1.188
	20°	0.377	1.188
	25°	0.415	1.188

- ▶ Note: "A" Dimension specified will provide approximately .001" clearance with D2 press fit.

# SPRINGS

## MEDIUM DUTY (BLUE)

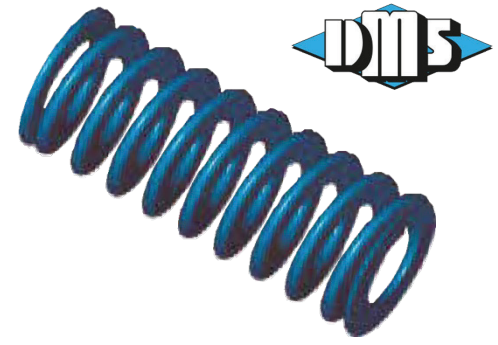

Raymond  
Die Springs

Hole Dia. OD	Rod Dia. ID	Free Length	Catalog Number	Load at 1/10" Deflec. (lbs.)	Max. Operating Deflection 40% of free length	
					Load (lbs.)	Deflec. (in.)
					3/8	3/16
		1-1/4"	037M0125	5.4	27.0	0.50
		1-1/2"	037M0150	4.0	24.0	0.60
		1-3/4"	037M0175	3.4	23.8	0.70
		2"	037M0200	2.8	22.4	0.80
		2-1/2"	037M0250	2.4	24.0	1.00
		3"	037M0300	2.1	25.2	1.20
		12"	037M1200	0.6	28.8	4.80
1/2	9/32	1"	050M0100	11.0	44.0	0.40
		1-1/4"	050M0125	8.2	41.0	0.50
		1-1/2"	050M0150	6.8	40.8	0.60
		1-3/4"	050M0175	6.0	42.0	0.70
		2"	050M0200	5.5	44.0	0.80
		2-1/2"	050M0250	4.5	45.0	1.00
		3"	050M0300	3.5	42.0	1.20
		3-1/2"	050M0350	3.0	42.0	1.40
		4-1/2"	050M0450	2.5	45.0	1.80
		5-1/2"	050M0550	2.1	46.2	2.20
		6-1/2"	050M0650	1.4	36.4	2.60
		7-1/2"	050M0750	1.2	36.0	3.00
		12"	050M1200	0.7	33.6	4.80
		5/8	11/32	1"	062M0100	16.4
1-1/4"	062M0125			12.8	64.0	0.50
1-1/2"	062M0150			10.8	64.8	0.60
1-3/4"	062M0175			9.6	67.2	0.70
2"	062M0200			8.8	70.4	0.80
2-1/2"	062M0250			6.0	60.0	1.00
3"	062M0300			5.6	67.2	1.20
3-1/2"	062M0350			4.8	67.2	1.40
4"	062M0400			4.4	70.4	1.60
12"	062M1200			1.6	76.8	4.80
3/4	3/8	1"	075M0100	31.2	124.8	0.40
		1-1/4"	075M0125	25.6	128.0	0.50
		1-1/2"	075M0150	20.0	120.0	0.60
		1-3/4"	075M0175	17.6	123.2	0.70
		2"	075M0200	14.4	115.2	0.80
		2-1/2"	075M0250	12.0	120.0	1.00
		3"	075M0300	9.6	115.2	1.20
		3-1/2"	075M0350	8.0	112.0	1.40
		4"	075M0400	7.2	115.2	1.60
		4-1/2"	075M0450	6.4	115.2	1.80
		5"	075M0500	6.0	120.0	2.00
		5-1/2"	075M0550	5.5	121.0	2.20
		6"	075M0600	5.0	120.0	2.40
		6-1/2"	075M0650	4.5	117.0	2.60
		7-1/2"	075M0750	3.8	114.0	3.00
		12"	075M1200	2.4	115.2	4.80
1"	1/2	1"	100M0100	55.0	220.0	0.40
		1-1/4"	100M0125	45.0	225.0	0.50
		1-1/2"	100M0150	35.0	210.0	0.60
		1-3/4"	100M0175	30.0	210.0	0.70
		2"	100M0200	26.0	208.0	0.80

Hole Dia. OD	Rod Dia. ID	Free Length	Catalog Number	Load at 1/10" Deflec. (lbs.)	Max. Operating Deflection 40% of free length	
					Load (lbs.)	Deflec. (in.)
					1"	1/2
3"	100M0300	16.5	198.0	1.20		
3-1/2"	100M0350	15.0	210.0	1.40		
4"	100M0400	12.0	192.0	1.60		
4-1/2"	100M0450	10.4	187.2	1.80		
5"	100M0500	9.6	192.0	2.00		
5-1/2"	100M0550	8.8	193.6	2.20		
6"	100M0600	8.0	192.0	2.40		
7"	100M0700	7.2	201.6	2.80		
8"	100M0800	6.0	192.0	3.20		
12"	100M1200	4.0	192.0	4.80		
1-1/4	5/8	1-1/2"	125M0150	49.6		
		1-3/4"	125M0175	42.4	296.8	0.70
		2"	125M0200	35.2	281.6	0.80
		2-1/2"	125M0250	28.8	288.0	1.00
		3"	125M0300	24.0	288.0	1.20
		3-1/2"	125M0350	20.0	280.0	1.40
		4"	125M0400	17.6	281.6	1.60
		4-1/2"	125M0450	16.0	288.0	1.80
		5"	125M0500	13.6	272.0	2.00
		5-1/2"	125M0550	12.8	281.6	2.20
		6"	125M0600	12.0	288.0	2.40
		7"	125M0700	10.4	291.2	2.80
8"	125M0800	8.8	281.6	3.20		
10"	125M1000	7.2	288.0	4.00		
12"	125M1200	6.0	288.0	4.80		
1-1/2	3/4	2"	150M0200	53.0	424.0	0.80
		2-1/2"	150M0250	45.0	450.0	1.00
		3"	150M0300	36.0	432.0	1.20
		3-1/2"	150M0350	30.0	420.0	1.40
		4"	150M0400	27.0	432.0	1.60
		4-1/2"	150M0450	23.0	414.0	1.80
		5"	150M0500	21.0	420.0	2.00
		5-1/2"	150M0550	18.5	407.0	2.20
		6"	150M0600	17.0	408.0	2.40
		7"	150M0700	14.5	406.0	2.80
		8"	150M0800	12.8	409.6	3.20
		10"	150M1000	10.0	400.0	4.00
12"	150M1200	8.0	384.0	4.80		
2"	1"	2-1/2"	200M0250	100.0	1000.0	1.00
		3"	200M0300	83.0	996.0	1.20
		3-1/2"	200M0350	64.8	907.2	1.40
		4"	200M0400	60.0	960.0	1.60
		4-1/2"	200M0450	53.0	954.0	1.80
		5"	200M0500	47.0	940.0	2.00
		5-1/2"	200M0550	39.2	862.4	2.20
		6"	200M0600	39.0	936.0	2.40
		7"	200M0700	31.2	873.6	2.80
		8"	200M0800	28.5	912.0	3.20
		10"	200M1000	20.8	832.0	4.00
		12"	200M1200	17.5	840.0	4.80

# SPRINGS

## MEDIUM HEAVY DUTY (RED)

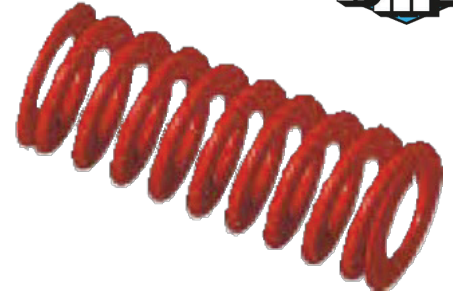

Raymond  
Die Springs

Hole Dia. OD	Rod Dia. ID	Free Length	Catalog Number	Load at 1/10" Deflec. (lbs.)	Max. Operating Deflection 30% of free length	
					Load	Deflec.
					(lbs.)	(in.)
3/8	3/16	1"	037MH0100	9.0	27.0	0.30
		1-1/4"	037MH0125	7.3	27.4	0.38
		1-1/2"	037MH0150	6.7	30.2	0.45
		1-3/4"	037MH0175	5.8	30.5	0.53
		2"	037MH0200	5.0	30.0	0.60
		2-1/2"	037MH0250	4.2	31.5	0.75
		3"	037MH0300	3.0	27.0	0.90
1/2	9/32	12"	037MH1200	0.9	32.4	3.60
		1"	050MH0100	16.8	50.4	0.30
		1-1/4"	050MH0125	13.0	48.8	0.38
		1-1/2"	050MH0150	9.5	42.8	0.45
		1-3/4"	050MH0175	8.5	44.6	0.53
		2"	050MH0200	7.5	45.0	0.60
		2-1/2"	050MH0250	6.0	45.0	0.75
		3"	050MH0300	5.7	51.3	0.90
		3-1/2"	050MH0350	4.0	42.0	1.05
5/8	11/32	12"	050MH1200	1.2	43.2	3.60
		1"	062MH0100	30.0	90.0	0.30
		1-1/4"	062MH0125	21.5	80.6	0.38
		1-1/2"	062MH0150	19.0	85.5	0.45
		1-3/4"	062MH0175	16.8	88.2	0.53
		2"	062MH0200	14.8	88.8	0.60
		2-1/2"	062MH0250	11.5	86.3	0.75
		3"	062MH0300	10.0	90.0	0.90
		3-1/2"	062MH0350	8.5	89.3	1.05
		4"	062MH0400	7.6	91.2	1.20
3/4	3/8	12"	062MH1200	2.7	97.2	3.60
		1"	075MH0100	50.0	150.0	0.30
		1-1/4"	075MH0125	38.0	142.5	0.38
		1-1/2"	075MH0150	32.0	144.0	0.45
		1-3/4"	075MH0175	28.8	151.2	0.53
		2"	075MH0200	24.8	148.8	0.60
		2-1/2"	075MH0250	19.2	144.0	0.75
		3"	075MH0300	14.4	129.6	0.90
		3-1/2"	075MH0350	12.8	134.4	1.05
		4"	075MH0400	12.0	144.0	1.20
		4-1/2"	075MH0450	11.2	151.2	1.35
		5"	075MH0500	9.0	135.0	1.50
		5-1/2"	075MH0550	8.0	132.0	1.65
		6"	075MH0600	7.5	135.0	1.80
1"	1/2	12"	075MH1200	3.6	129.6	3.60
		1"	100MH0100	76.0	228.0	0.30
		1-1/4"	100MH0125	62.4	234.0	0.38
		1-1/2"	100MH0150	49.6	223.2	0.45
		1-3/4"	100MH0175	44.0	231.0	0.53
		2"	100MH0200	40.0	240.0	0.60
		2-1/2"	100MH0250	31.0	232.5	0.75
		3"	100MH0300	25.0	225.0	0.90
		3-1/2"	100MH0350	21.6	226.8	1.05
		4"	100MH0400	18.4	220.8	1.20
		4-1/2"	100MH0450	17.0	229.5	1.35
		5"	100MH0500	14.4	216.0	1.50

Hole Dia. OD	Rod Dia. ID	Free Length	Catalog Number	Load at 1/10" Deflec. (lbs.)	Max. Operating Deflection 30% of free length	
					Load	Deflec.
					(lbs.)	(in.)
1"	1/2	5-1/2"	100MH0550	12.8	211.2	1.65
		6"	100MH0600	12.0	216.0	1.80
		7"	100MH0700	10.0	210.0	2.10
		8"	100MH0800	8.8	211.2	2.40
		12"	100MH1200	6.2	223.2	3.60
1-1/4	5/8	1-1/2"	125MH0150	114.4	514.8	0.45
		1-3/4"	125MH0175	100.8	529.2	0.53
		2"	125MH0200	86.4	518.4	0.60
		2-1/2"	125MH0250	62.4	468.0	0.75
		3"	125MH0300	51.2	460.8	0.90
		3-1/2"	125MH0350	44.0	462.0	1.05
		4"	125MH0400	36.8	441.6	1.20
		4-1/2"	125MH0450	32.0	432.0	1.35
		5"	125MH0500	29.0	435.0	1.50
		5-1/2"	125MH0550	26.4	435.6	1.65
		6"	125MH0600	25.0	450.0	1.80
		7"	125MH0700	20.0	420.0	2.10
		8"	125MH0800	18.4	441.6	2.40
10"	125MH1000	14.5	435.0	3.00		
12"	125MH1200	12.4	446.4	3.60		
1-1/2	3/4	2"	150MH0200	108.0	648.0	0.60
		2-1/2"	150MH0250	85.6	642.0	0.75
		3"	150MH0300	62.4	561.6	0.90
		3-1/2"	150MH0350	52.8	554.4	1.05
		4"	150MH0400	48.0	576.0	1.20
		4-1/2"	150MH0450	43.2	583.2	1.35
		5"	150MH0500	36.8	552.0	1.50
		5-1/2"	150MH0550	34.4	567.6	1.65
		6"	150MH0600	30.4	547.2	1.80
		7"	150MH0700	26.4	554.4	2.10
		8"	150MH0800	22.0	528.0	2.40
		10"	150MH1000	17.6	528.0	3.00
		12"	150MH1200	14.4	518.4	3.60
2"	1"	2-1/2"	200MH0250	118.4	888.0	0.75
		3"	200MH0300	96.0	864.0	0.90
		3-1/2"	200MH0350	80.0	840.0	1.05
		4"	200MH0400	66.4	796.8	1.20
		4-1/2"	200MH0450	60.0	810.0	1.35
		5"	200MH0500	56.0	840.0	1.50
		5-1/2"	200MH0550	50.4	831.6	1.65
		6"	200MH0600	47.2	849.6	1.80
		7"	200MH0700	40.0	840.0	2.10
		8"	200MH0800	35.2	844.8	2.40
		10"	200MH1000	26.0	780.0	3.00
		12"	200MH1200	22.4	806.4	3.60

# SPRINGS

## HEAVY DUTY (GOLD)



### Raymond Die Springs

Hole Dia. OD	Rod Dia. ID	Free Length	Catalog Number	Load at 1/10" Deflec. (lbs.)	Max. Operating Deflection 25% of free length	
					Load	Deflec.
					(lbs.)	(in.)
3/8	3/16	1"	037H0100	11.0	27.5	0.25
		1-1/4"	037H0125	9.8	30.6	0.31
		1-1/2"	037H0150	8.0	30.0	0.38
		1-3/4"	037H0175	8.4	36.8	0.44
		2"	037H0200	7.2	36.0	0.50
		2-1/2"	037H0250	5.5	34.4	0.63
		3"	037H0300	4.2	31.5	0.75
1/2	9/32	12"	037H1200	1.2	36.0	3.00
		1"	050H0100	23.6	59.0	0.25
		1-1/4"	050H0125	18.6	58.1	0.31
		1-1/2"	050H0150	15.5	58.1	0.38
		1-3/4"	050H0175	13.8	60.4	0.44
		2"	050H0200	11.0	55.0	0.50
		2-1/2"	050H0250	8.4	52.5	0.63
		3"	050H0300	7.4	55.5	0.75
		3-1/2"	050H0350	6.0	52.5	0.88
5/8	11/32	12"	050H1200	1.6	48.0	3.00
		1"	062H0100	42.4	106.0	0.25
		1-1/4"	062H0125	29.6	92.5	0.31
		1-1/2"	062H0150	27.2	102.0	0.38
		1-3/4"	062H0175	24.0	105.0	0.44
		2"	062H0200	20.8	104.0	0.50
		2-1/2"	062H0250	17.0	106.3	0.63
		3"	062H0300	14.4	108.0	0.75
		3-1/2"	062H0350	12.2	106.8	0.88
		4"	062H0400	10.8	108.0	1.00
		12"	062H1200	3.0	90.0	3.00
3/4	3/8	1"	075H0100	108.0	270.0	0.25
		1-1/4"	075H0125	88.0	275.0	0.31
		1-1/2"	075H0150	65.6	246.0	0.38
		1-3/4"	075H0175	60.0	262.5	0.44
		2"	075H0200	49.6	248.0	0.50
		2-1/2"	075H0250	40.0	250.0	0.63
		3"	075H0300	34.0	255.0	0.75
		3-1/2"	075H0350	28.0	245.0	0.88
		4"	075H0400	25.0	250.0	1.00
		4-1/2"	075H0450	22.0	247.5	1.13
		5"	075H0500	19.5	243.8	1.25
		5-1/2"	075H0550	17.0	233.8	1.38
		6"	075H0600	16.0	240.0	1.50
		12"	075H1200	8.0	240.0	3.00
1"	1/2	1"	100H0100	208.0	520.0	0.25
		1-1/4"	100H0125	171.2	535.0	0.31
		1-1/2"	100H0150	118.4	444.0	0.38
		1-3/4"	100H0175	104.0	455.0	0.44
		2"	100H0200	90.0	450.0	0.50
		2-1/2"	100H0250	68.0	425.0	0.63
		3"	100H0300	54.4	408.0	0.75
		3-1/2"	100H0350	45.6	399.0	0.88
		4"	100H0400	40.0	400.0	1.00
		4-1/2"	100H0450	35.2	396.0	1.13
		5"	100H0500	31.2	390.0	1.25

Hole Dia. OD	Rod Dia. ID	Free Length	Catalog Number	Load at 1/10" Deflec. (lbs.)	Max. Operating Deflection 25% of free length	
					Load	Deflec.
					(lbs.)	(in.)
1"	1/2	5-1/2"	100H0550	28.8	396.0	1.38
		6"	100H0600	25.6	384.0	1.50
		7"	100H0700	22.4	392.0	1.75
		8"	100H0800	19.2	384.0	2.00
		12"	100H1200	12.0	360.0	3.00
1-1/4	5/8	1-1/2"	125H0150	212.0	795.0	0.38
		1-3/4"	125H0175	181.6	794.5	0.44
		2"	125H0200	149.6	748.0	0.50
		2-1/2"	125H0250	117.6	735.0	0.63
		3"	125H0300	95.2	714.0	0.75
		3-1/2"	125H0350	75.2	658.0	0.88
		4"	125H0400	66.4	664.0	1.00
		4-1/2"	125H0450	58.4	657.0	1.13
		5"	125H0500	53.0	662.5	1.25
		5-1/2"	125H0550	47.2	649.0	1.38
		6"	125H0600	42.4	636.0	1.50
		7"	125H0700	36.8	644.0	1.75
		8"	125H0800	32.8	656.0	2.00
		10"	125H1000	25.6	640.0	2.50
12"	125H1200	20.8	624.0	3.00		
1-1/2	3/4	2"	150H0200	190.4	952.0	0.50
		2-1/2"	150H0250	155.0	968.8	0.63
		3"	150H0300	130.0	975.0	0.75
		3-1/2"	150H0350	106.4	931.0	0.88
		4"	150H0400	91.2	912.0	1.00
		4-1/2"	150H0450	78.4	882.0	1.13
		5"	150H0500	71.2	890.0	1.25
		5-1/2"	150H0550	64.0	880.0	1.38
		6"	150H0600	58.4	876.0	1.50
		7"	150H0700	49.6	868.0	1.75
		8"	150H0800	43.2	864.0	2.00
		10"	150H1000	34.4	860.0	2.50
12"	150H1200	28.8	864.0	3.00		
2"	1"	2-1/2"	200H0250	260.0	1625.0	0.63
		3"	200H0300	200.0	1500.0	0.75
		3-1/2"	200H0350	170.0	1487.5	0.88
		4"	200H0400	150.0	1500.0	1.00
		4-1/2"	200H0450	120.0	1350.0	1.13
		5"	200H0500	110.0	1375.0	1.25
		5-1/2"	200H0550	100.0	1375.0	1.38
		6"	200H0600	94.0	1410.0	1.50
		7"	200H0700	82.0	1435.0	1.75
		8"	200H0800	73.0	1460.0	2.00
		10"	200H1000	55.0	1375.0	2.50
		12"	200H1200	42.0	1260.0	3.00

# AIR POPPETS STANDARD

> Designed to assist in breaking the vacuum created when molding deep molded parts or thin walled parts such as flower pots, garbage cans and containers.

> The valve and body are made from hard Stainless Steel 45-50 HRC.

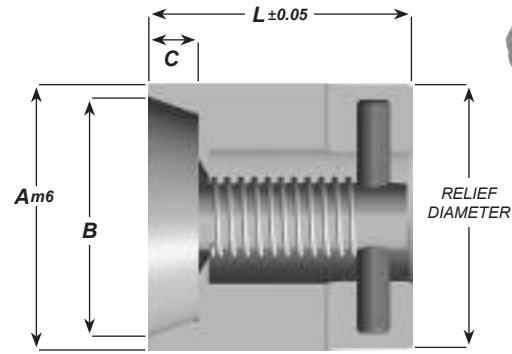
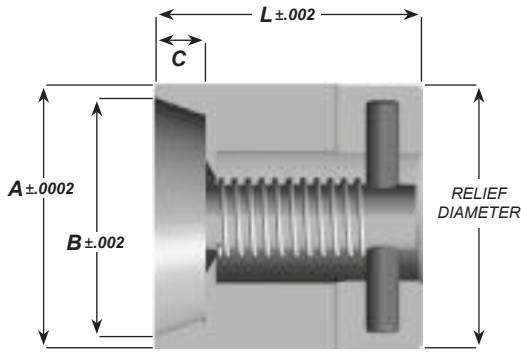

INCH					
Cat. No.	Nominal I.D.	A	B	L	C
AE025	1/4	0.251	0.225	0.252	0.05
AE037	3/8	0.376	0.325	0.377	0.07
AE050	1/2	0.501	0.437	0.502	0.10
AE062	5/8	0.626	0.562	0.627	0.13
AE075	3/4	0.751	0.656	0.752	0.15
AE100	1"	1.001	0.875	1.002	0.20
AE150	1-1/2	1.501	1.312	1.502	0.30

METRIC					
Cat. No.	Nominal I.D.	A	B	L	C
AE08MM	8	0.315	6.5	12	1,5
AE10MM	10	0.394	8	12	2,0
AE12MM	12	0.472	10	12	2,5
AE16MM	16	0.630	13	20	3
AE20MM	20	0.787	17	20	3,5

# PLUNGER-STYLE METRIC

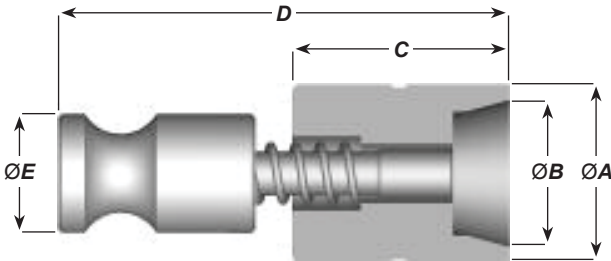

420 Stainless Steel 50-55 HRC.

Cat. No.	A	B	C	D	E
EP-01	8 +0,018 +0,007	6,6	11	24	6
AEP-02	12 +0,018 +0,007	9,7	18	34	8
AEP-03	18 +0,018 +0,007	14,8	22	45,5	12



# FILTERED METRIC



Catalog Number	A	B	C	E
FV.161320	16	13	20	14
FV.201720	20	17	20	18

> Incorporating a sintered bronze filter ensuring that debris cannot affect the valve's proper function.

> The material is INOX. 1.4304 HRC 48-54.

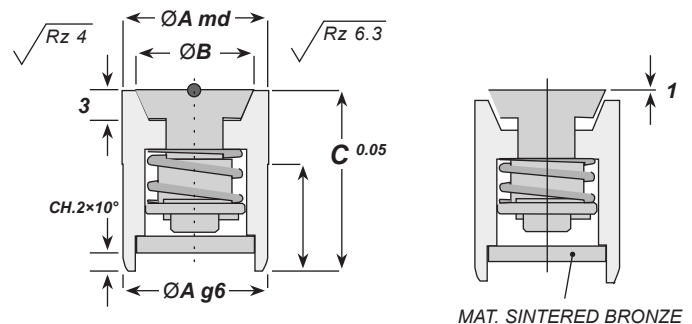

# SINTERED VENTS

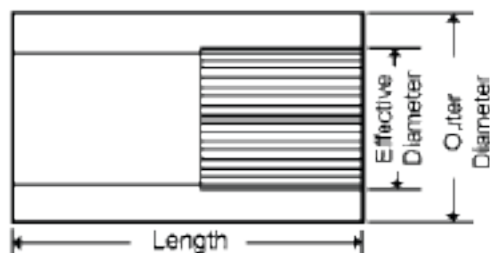

## PLASTIC INJECTION MOLDING (Pore Diameter: 0.03–0.10mm)

CAT. NO.	O.D.	EFF. D.	PORES	L
003–0610	6	2.5	880	10
003–0810	8	2.5	880	10
003–1010	10	2.5	880	10
005–0610	6	3.5	880	10
005–0810	8	3.5	880	10
005–1010	10	3.5	880	10
01–0810	8	5.5	880	10
01–1010	10	5.5	880	10

KIC Sintered Vents are composed of several straight and uniform pores made through a unique process to allow air or gas that gets trapped inside the mold cavity during the injection or die casting process to escape freely. To optimize mold design and reduce the possibility of manufacturing defective parts, specify strategically placed insertion points to hold the vents.

KIC Sintered Vents with ultra fine pores (diameters of 0.03mm) have been used successfully in venting systems for plastic injection mold applications. The passage of trapped air and gases can be properly released while blocking the escape of molten plastic. With KIC Sintered Vents, you get shorter shot-cycles while dramatically increasing productivity.

KIC Sintered Vents with a pore diameter of 0.4mm are suitable for larger, gravity die-cast parts, while 0.5mm diameter vents are more suited for smaller parts. Low pressure die-cast, or vacuum casting parts require pore diameters between 0.2 and 0.3mm.

○ Pore Diameter

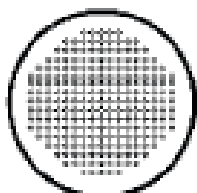
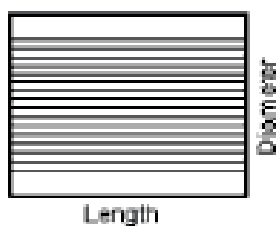

## GRAVITY DIE-CASTING (Pore Diameter: 0.5± mm)

CAT.NO.	DIA.	PORES	L
05–0310	3	40	10
05–0410	4	40	10
05–0510	5	60	10
05–0610	6	60	10
05–0615	6	60	15
05–0810	8	100	10
05–0815	8	100	15
05–1010	10	200	10
05–1015	10	200	15
05–1210	12	200	10
05–1215	12	200	15
05–1415	14	340	15
05–1615	16	240	15
05–1815	18	550	15
05–2015	20	550	15
05–2815	28	970	15

**PRODUCTIVITY:** Fast and easy exchange of venting plugs; easy cleaning of molding dies.  
**EFFICIENCY:** Perforation volumes are 5–30 times higher than ordinary venting plugs.

**DURABILITY:** Decrease replacement frequency of venting plugs.

**QUALITY:** Drastically decreases defects such as pin holes, mis-run, and short-shots.

**SELECTION:** Pore sizes range from 0.03 to 0.5mm; length and diameter of vents to meet your needs.

### PLEASE NOTE

- › We can supply custom vents made to your specification.
- › During installation, do not strike the vent pores.
- › Keep insertion tolerances between 0.025 and 0.05mm.
- › Actual pore diameters and specifications may vary slightly and are subject to change without notice.

## LOW PRESSURE DIE-CASTING AND VACUUM CASTING (Pore Diameter: 0.3± mm)

CAT. NO.	DIA.	PORES	L
03–0510	5	90	10
03–0610	6	90	10
03–0615	6	90	15
03–0810	8	200	10
03–0815	8	200	15
03–1010	10	340	10
03–1015	10	340	15
03–1210	12	340	10
03–1215	12	340	15
03–1415	14	550	15

- › CODING SYSTEM EXAMPLE: 005–0610
- › 0.05 Pore Dia. (mm) 06 Vent Dia. (mm) 10 Vent L. (mm)

# FRONT-REMOVABLE DATE STAMPS

## ECONOMY SERIES "E"

- > Material: 420 Stainless; 1.4021;46Hrc+/- 2
- > Provides part traceability
- > Maximum working Temperature: 300F
- > Markings are Laser etched.
- > Insert changes can be done from parting line
- > Press fit installation required Interchangeable with DME Front
- > Removable or Progressive C-series



D	L	12 Months w/arrow	12 Months w arrow/year	Years/ arrow**	Days/ arrow	Shifts/ arrow	Numeral 0-9	Blank/ arrow
4	8	M408	M04 x __	A04 x __	DA04	SH04		BL408
5	8	M508	M05 x __	A05 x __	DA05	SH05		BL508
6	8	M608	M06 x __	A06 x __	DA06	SH06	FOR0006	BL608
8	10	M810	M08 x __	A08 x __	DA08	SH08	FOR0008	BL810
10	12	M1012	M10 x __	A10 x __	DA10	SH10	FOR0010	BL1012
12	14	M1214	M12 x __	A12 x __	DA12	SH12	FOR0012	BL1214
16	14	M1614	M16 x __	A16 x __	DA16	SH16	FOR0016	BL1614
20	16	M2016	M20 x __	A20 x __	DA20	SH20	FOR0020	BL2016

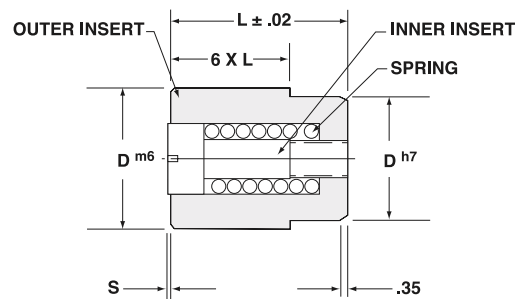

NOTE: Press fit installation required in mold.

- > \* When ordering add the year required to the part number (M05 x 07)
- > \*\*When ordering specify beginning year

## REPLACEMENT INSERTS & BODIES

### Dimensional Data

D(mm) Dia.	E (mm)	L(mm) Length	S(mm) Etch Depth	Tolerance(mm)	
				m6	h7
4	2,1	8	0.203	+0,12 to +,004	0 to -,012
5	3,1	8	0.203	+0,12 to +,004	0 to -,012
6	3,1	8	0.203	+0,12 to +,004	0 to -,012
8	4,4	10	0.254	+0,15 to +,006	0 to -,015
10	5,2	12	0.356	+0,15 to +,006	0 to -,015
12	6,2	14	0.356	+0,18 to +,007	0 to -,018
16	8,2	14	0.356	+0,18 to +,007	0 to -,018
20	11	16	0.356	+0,21 to +,008	0 to ,021

### Replacement Inserts (with springs)

Arrow Only	Arrow & Year*	C	L2
AR04	AY04	2,1	8
AR05	AY05	3,1	8
AR06	AY06	3,1	8
AR08	AY08	4,4	10
AR10	AY10	5,2	12
AR12	AY12	6,2	14
AR16	AY16	8,2	14
AR20	AY20	11	16

### REPLACEMENT BODIES

D	L	12 Months	Days	Shifts	Blank
4	8	MB04	DB04	SB04	BL04
5	8	MB05	DB05	SB05	BL05
6	8	MB06	DB06	SB06	BL06
8	10	MB08	DB08	SB08	BL08
10	12	MB10	DB10	SB10	BL10
12	14	MB12	DB12	SB12	BL12
16	14	MB16	DB16	SB16	BL16
20	16	MB20	DB20	SB20	BL20

### Replacement Springs (pkg of 5)

D(mm) Diameter	Cat. Number
4	RS04
5	RS05
6	RS06
8	RS08
10	RS10
12	RS12
16	RS16
20	RS20

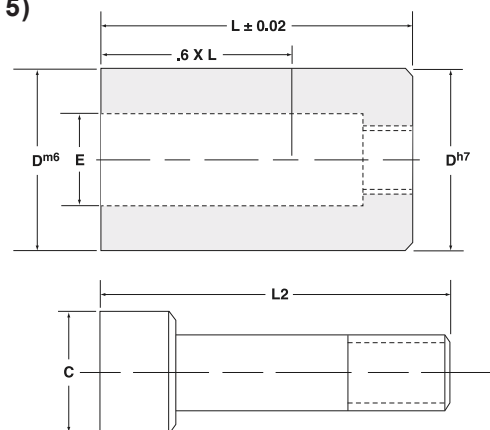

NOTE: Press fit installation required in mold.

- > \* When ordering add the year required to the part number

# DUAL RING DATE STAMPS

## Dual-Ring Mold Dating Insert

### Offers the Ultimate in Date Insertion Flexibility

Patented Indexable Mold Date Insert Technology

The Dual-Ring Mold Dating Insert features a date insert valid for six years. and is based on Indexable Mold Date Insert technology.

The Dual-Ring Insert eliminates the need to install two date inserts or change the inner insert each year. This easy-to-use indexable insert provides the flexibility you need to keep your mold dating current, especially as the lifetime of molds becomes shorter.

- > Outer ring: 12 months, months 1 through 12
- > Inner ring: 6 years + arrow (arrow points to month)
- > Center insert: arrow (points to year & adjusts position of both arrows)

### Offers the Ultimate in Date Insertion Flexibility

- > Double indexable: both arrows independently "click into position"
- > Change positions easily with only a screwdriver using arrow in inner insert
- > Turn clockwise to change "year" arrow (6 years)
- > Turn counter-clockwise to change "month" arrow (12 months)
- > **All inserts remain flush when rotated**
- > Dual-Ring Inserts may be interchanged for the 20mm, 16mm, 10mm, 8mm to 6mm diameter Indexable and Front Removable inserts



Patent Pending

### Installation and Meaning

- > Press-fit installation required
- > Maintain a close tolerance press fit. Too loose a fit could allow the insert to move out of position, while too tight a press fit might prevent the inner insert and inner ring from rotating when required
- > Accurately measure the  $\varnothing D$  for each part and machine  $\varnothing G$  hole to provide about 0.005mm (0.0002") press fit.

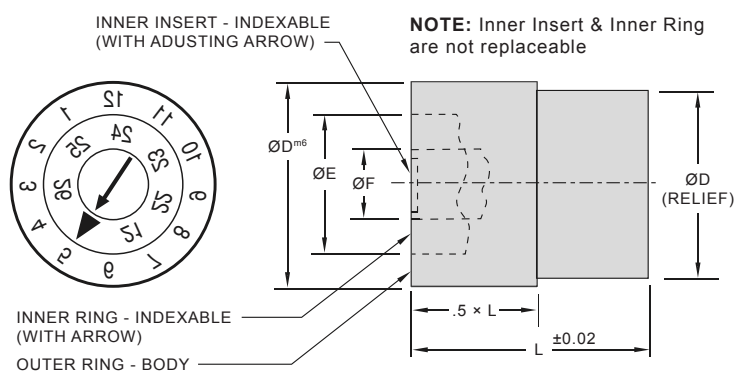

Pocket for installation  
(hold pocket depth as required by the application)

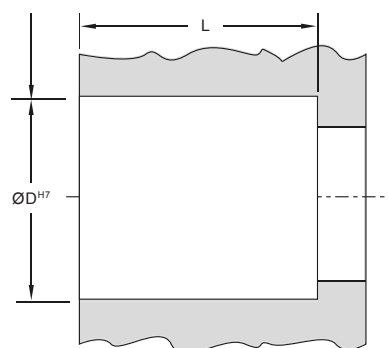

### Dual Ring Mold Dating Inserts – MD and Assembly

Ø D	TOLERANCE	
	m6	h7
6	+0.004 TO +0.012	0.000 TO -0.012
8	+0.006 TO +0.015	0.000 TO -0.015
10	+0.006 TO +0.015	0.000 TO -0.015
16	+0.007 TO +0.018	0.000 TO -0.018
20	+0.008 TO +0.021	0.000 TO -0.021

#### INFORMATION KEY:

D = Outside Diameter  
 E = Outside Diameter of Inner Ring  
 F = Outside Diameter of Inner Insert  
 G = Hole Diameter  
 L = Length  
 Material: Corrosion-resistant Stainless Steel  
 Hardness: 53 ± 3 HRC  
 Max. T emp: 150°C (300°F)  
 Dimensions: All dimensions are in mm, except as noted

ITEM NUMBER	Ø D	Ø E	Ø F	L LENGTH
MD 20 20 *_*	20	12.8	6.2	16
MD 16 20 *_*	16	10.6	5	14
MD 10 20 *_*	10	6.4	3.2	12
MD 08 20 *_*	8	5.3	2.5	10
MD 06 20 *_*	6	3.8	1.8	10

\*When ordering, add digits of engraved year required where asterisks (\*\_\*) are shown in item number (e.g., MD 0620\_\*\_\*: MD 062022; MD 1020\_\*\_\*: MD 102022).

# DOUBLE DATE STAMP

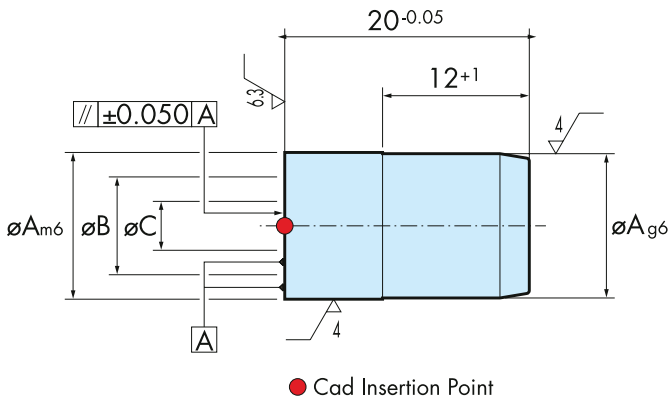

12 Months + Year	Blank	A	B	C	E	N
FD.080512 __	FD.080500	8	5.5	3	6	5
FD.120812 __	FD.120800	12	8	4	10	6
FD.161012 __	FD.161000	16	10.5	5.3	12	10

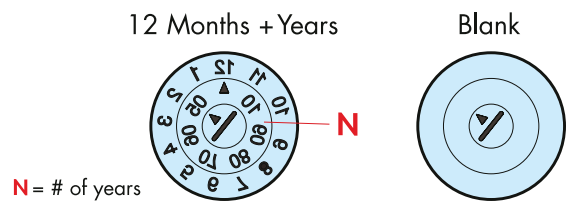

To order — Add the last two digits of the start or base year to catalog number. Example for start or base year of 2011: FD-080512**11**

Fig. 1  
To change month

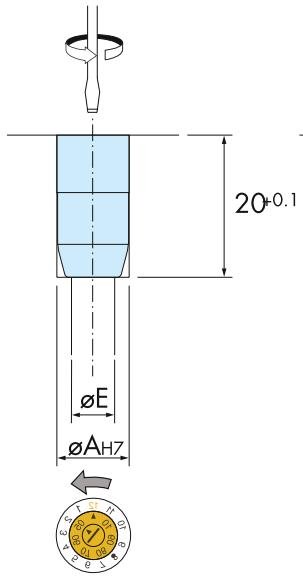
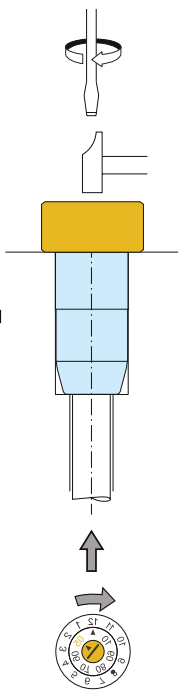

Fig. 2  
To change year



- › Replaces the need for 2 separate date stamps
- › No need to machine 2 separate holes
- › Minimum space required for installation
- › Special engraving available upon request.
- › Material: INOX. 1.4034  
Hardened 51 ± 3 HRC
- › Maximum working temperature 100°C
- › This is a CUMSA patented system

**IMPORTANT:** To change the month, turn counter clockwise (the two inner rings move, Fig. 1). To change the year, turn clockwise (only the central ring moves, Fig. 2).

# DATE STAMPS

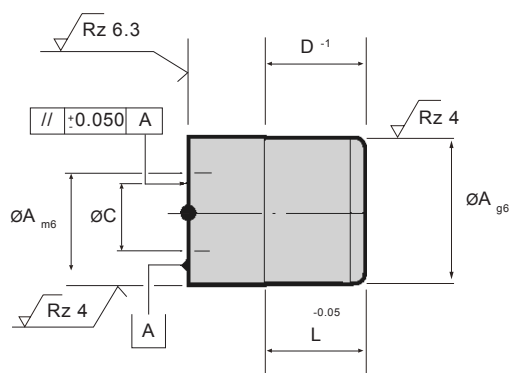

- > Material is INOX. 1.4034 48-54HRC.
- > Maximum working temperature is 150° C



12 Months	12 Mon. + Yr.1	Years1	Blank	31 Days	Shifts	A	C	D	E	L	N2
FA.0422SF	FA.042212-__	FA.042204-__	FA.042200		FA.0422SP	4	2.2	6	3.5	12	4
FA.0530SF	FA.053012-__	FA.053004-__	FA.053000		FA.0530SP	5	3	6	3.5	12	4
FA.0632SF	FA.063212-__	FA.063205-__	FA.063200	FA.0632-31	FA.0632SP	6	3.2	12	4	20	5
FA.0847SF	FA.084712-__	FA.084705-__	FA.084700	FA.0847-31	FA.0847SP	8	4.7	12	6	20	5
FA.1057SF	FA.105712-__	FA.105706-__	FA.105700	FA.1057-31	FA.1057SP	10	5.7	12	8	20	6
FA.1267SF	FA.126712-__	FA.126708-__	FA.126700	FA.1267-31	FA.1267SP	12	6.7	12	10	20	8
FA.1687SF	FA.168712-__	FA.168710-__	FA.168700	FA.1687-31	FA.1687SP	16	8.7	12	12	20	10
FA.2007SF	FA.200712-__	FA.200710-__	FA.200700	FA.2007-31	FA.2007SP	20	10.7	12	14	20	10

\*Assemblies supplied complete with outer ring and arrow insert.

- > (1) When ordering, add the year required to the part number (FA.042212**11**)
- > (2) The number of years that fit on the 'Year' outer ring.

# INSERTS

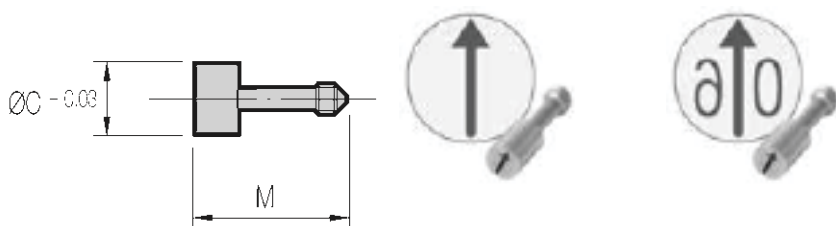

- > Material is INOX. 1.4034 48-54HRC
- > Insert changes can be done while the tool is still in the press.
- > To replace inserts, simply turn clockwise until the unit clicks (about 8 revolutions) mating the insert flush with the outer ring.

Arrow only	Arrow & Year1	C	M
IA.2275SF	IA.2275__	2.2	7.7
IA.3075SF	IA.3075__	3	7.7
IA.3217SF	IA.3217__	3.2	17
IA.4717SF	IA.4717__	4.7	17
IA.5717SF	IA.5717__	5.7	17
IA.6717SF	IA.6717__	6.7	17
IA.8717SF	IA.8717__	8.7	17
IA.1007SF	IA.1007__	10.7	17

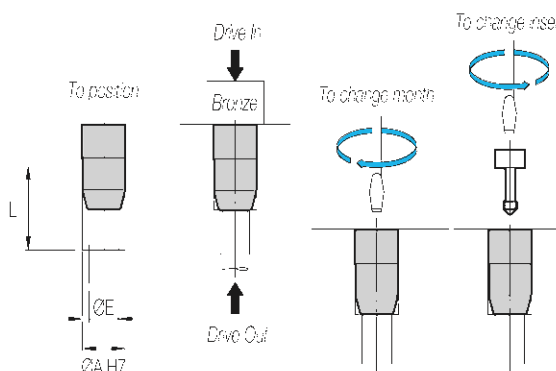

(1) When ordering, add the year required to the part number (IA.2275**11**)

CAD files flash demo at:  
**CUMSA** [www.cumsa.com](http://www.cumsa.com)

# RECYCLE INSERTS

## SPI STANDARDS

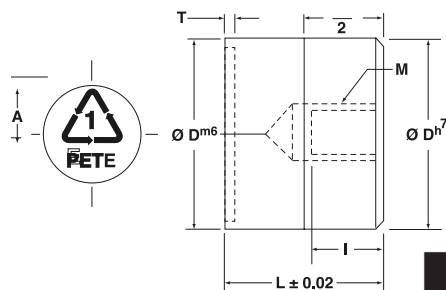

- > Standards with threaded holes
- > Based upon US SPI standards
- > Material: 420 Stainless; 1.4021; 46Hrc+/- 2
- > Maximum working temperature: 300F



D	L	A	M	T	I
8	10	5	M4	0,2	5
10	12	6	M5	0,3	7
12	14	7	M5	0,3	7
16	14	10	M6	0,3	7
20	16	12	M6	0,3	8



0



1



2



3



4



5



6



7

Catalog Number	D	Recycling Number	Abbreviation	Polymer Name
MA-08-01	8	1	PETE	Polyethelene, Terephthalate
MA-08-02	8	2	HDPE	High Density Polyethelene
MA-08-03	8	3	PVC(or V)	Polyvinyl Chloride
MA-08-04	8	4	LDPE	Low-Density Polyethelene
MA-08-05	8	5	PP	Polypropelene
MA-08-06	8	6	PS	Polystyrene
MA-08-07	8	7	"OTHER"	All other resins
MA-08-00	8	N/A	N/A	Blank
MA-10-01	10	1	PETE	Polyethelene, Terephthalate
MA-10-02	10	2	HDPE	High Density Polyethelene
MA-10-03	10	3	PVC(or V)	Polyvinyl Chloride
MA-10-04	10	4	LDPE	Low-Density Polyethelene
MA-10-05	10	5	PP	Polypropelene
MA-10-06	10	6	PS	Polystyrene
MA-10-07	10	7	"OTHER"	All other resins
MA-10-00	10	N/A	N/A	Blank
MA-12-01	12	1	PETE	"Polyethelene, Terephthalate"
MA-12-02	12	2	HDPE	High Density Polyethelene
MA-12-03	12	3	PVC(or V)	Polyvinyl Chloride
MA-12-04	12	4	LDPE	Low-Density Polyethelene
MA-12-05	12	5	PP	Polypropelene
MA-12-06	12	6	PS	Polystyrene
MA-12-07	12	7	"OTHER"	All other resins
MA-12-00	12	N/A	N/A	Blank
MA-16-01	16	1	PETE	Polyethelene, Terephthalate
MA-16-02	16	2	HDPE	High Density Polyethelene
MA-16-03	16	3	PVC(or V)	Polyvinyl Chloride
MA-16-04	16	4	LDPE	Low-Density Polyethelene
MA-16-05	16	5	PP	Polypropelene
MA-16-06	16	6	PS	Polystyrene
MA-16-07	16	7	"OTHER"	All other resins
MA-16-00	16	N/A	N/A	Blank
MA-20-01	20	1	PETE	Polyethelene, Terephthalate
MA-20-02	20	2	HDPE	High Density Polyethelene
MA-20-03	20	3	PVC(or V)	Polyvinyl Chloride
MA-20-04	20	4	LDPE	Low-Density Polyethelene
MA-20-05	20	5	PP	Polypropelene
MA-20-06	20	6	PS	Polystyrene
MA-20-07	20	7	"OTHER"	All other resins
MA-20-00	20	N/A	N/A	Blank

# FULL COLOUR MOLD PLAQUES

TOOLING IDENTIFICATION

**SAVE ENGINEERING  
TIME AND MONEY!**

**INDUSTRY PROVEN  
THERMAL SET GRAPHICS**

- › Simplified Data Transfers JPEG/PDF/PPT.
- › 300 DPI files (options available)
- › Dimension the part and email
- › Design any colour combinations
- › NOTE: Technical support available

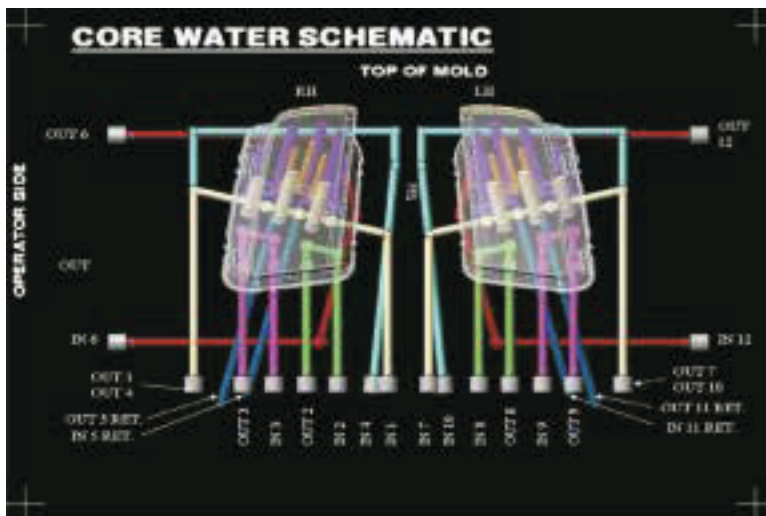

**ICS Laser  
Technologies**



## STANDARD I.D. MOLD PLAQUES

<b>NOVA</b> tool & mold Inc.			
CUSTOMER	SAMPLE I.D. PLAQUE ONLY		
PART NAME	CREATE YOUR OWN CUSTOM DESIGN!		
PART NO.	NO. CAV	1	
NOVA JOB NO.	2225	MOLD NO.	
MOLD WEIGHT	1,000 LBS	L	8.00 W 4.00 H 1.18
MANUFACTURED IN CANADA		JUN 2009	
<small>888 HILFORD DR., 88 #1, WINDSOR, ONTARIO CANADA TEL: (519) 757-7187 FAX: (519) 757-7111 EMAIL: info@novamold.com</small>			

## SERVICE IDENTIFICATION

THIS TOOL SERVICED BY	
<b>NOVA</b> tool & mold Inc.	

## DIE TAGS

<b>ICS Laser Technologies</b>	CUSTOMER PT. # 106022009	
	OPERATION DESCRIPTION FULL COLOUR SAMPLE DIE TAG	
Mtn Street, U.S.A. 48225 Phone: (800) 912-1234 Fax: (800) 912-5678	CUSTOMER NAME ICS LASER TECHNOLOGIES	Made in U.S.A.
JOB # 777	PT. NAME ID TAG	SHUT HEIGHT 1/8"
	WEIGHT OF UPPER DIE HALF 100 lbs. TOTAL WEIGHT 225 lbs. STOCK THICKNESS 3mm (0.157)	
	DIE SIZE 12" X 36" COIL WIDTH AND PROGRESSION 13" wide X 39" prog.	

## ASSET TAGS

YOUR LOGO HERE	PROPERTY OF YOUR COMPANY NAME
T895707-00-00	

- HIGH CUSTOMER APPROVAL RATING •
- Mold Magnets for Part Identification Also Available •

- Cost competitive
- Protective coated
- Quick turn around

# REDE VAULT

## THE 21<sup>ST</sup> CENTURY OWNER'S MANUAL

### INNOVATIVE SOFTWARE:

The RedE Vault mold management solution utilizes the RedE Vault easy-to-use mold management software and cloud backup services, providing you with offsite backup and 24/7 access to your mold data. The innovative RedE Vault system allows you to secure and store important process parameters, mold repair logs, and drawings while enforcing business practices, increasing mold technician accountability and assisting in ISO compliance with one easy to use storage solution. The RedE Innovations data services allow you to manage your mold data and provides a thorough overview of multiple molds through our secure website.

Our user friendly software was designed to help mold owners secure and manage their mold data while allowing quick and easy access to templates, drawings and files, with the administrative option to control each user's data access permissions. With 16GB of memory and the ability to optionally encrypt your files using the ASE-256 encryption algorithm the RedE Vault makes sure your data is easily accessible and never compromised.

### FEATURES:

- Online overview and management of
- RedE Vaults
- Password-protected access and file security
- File and data encryption
- Permanent on mold data storage
- View and update data via RedEVault.com
- Secure offsite backup
- Assists in ISO compliance
- Multilingual interface
- Stores all digital file types
- Custom data entry template designer
- Enforces business process
- Corporate branding
- Revision tracking
- Each RedE Vault has its own ID#

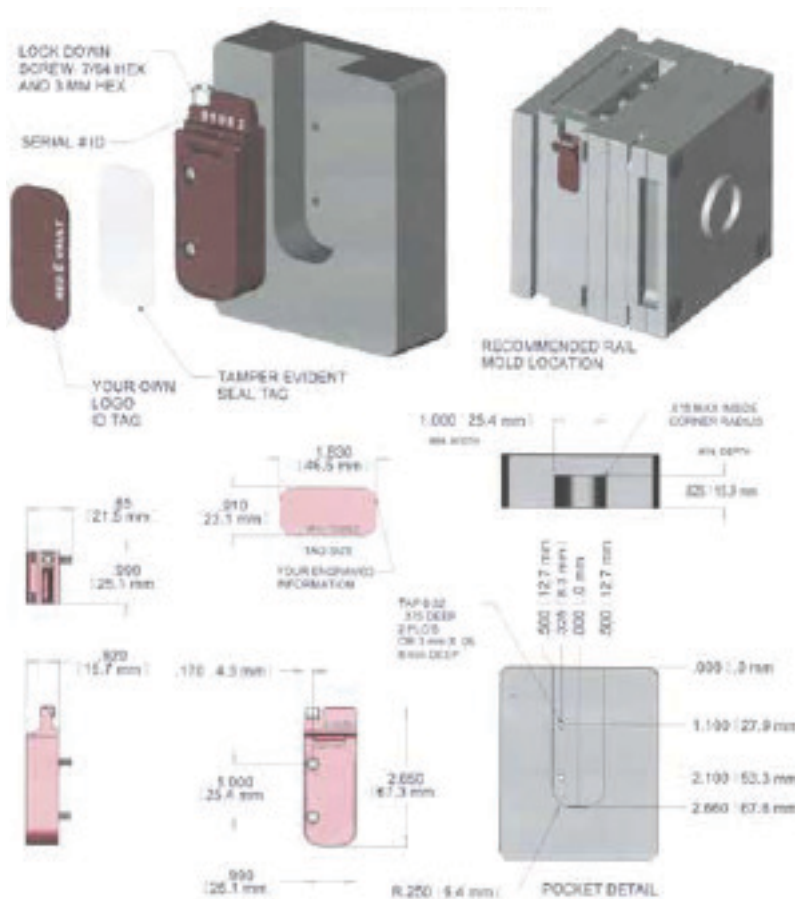

### YOUR MOLD DATA STORAGE SOLUTION

- Design Schematics & Prints
- Setup and Maintenance Data
- Part Specs and Materials
- Bill of Materials
- Part Picture and Video Storage
- Contracts
- Repair History
- Quality Control Logs

# IN-MOULD EDGE GATE CUTTING

- > The pin and sprue bushing provide automation in cutting large edge gates
- > The large gate enables a reduction in injection pressure
- > The large gate improves packing and part quality
- > The pin and brush are made from M2 Steel 62 HRC
- > Full drawings and 3D models can be downloaded from our website

## CUTTING PINS

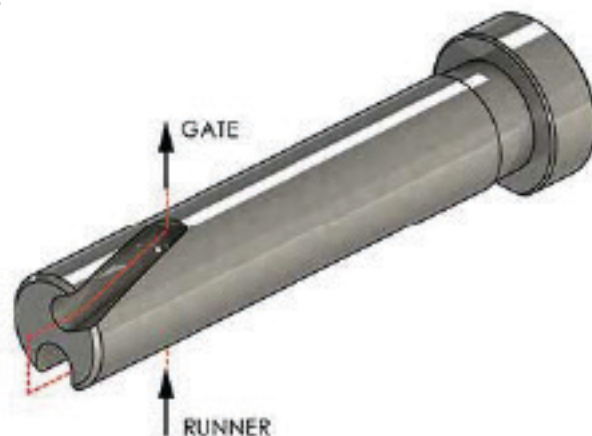
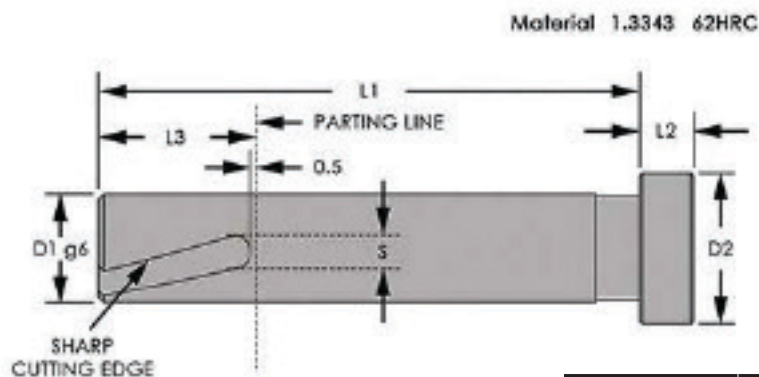

CATALOG NUMBER	D1	D2	L1	L2	L3	S	GATES
PI0.50.1	10mm	13.7mm	50mm	5mm	14.5mm	3mm	1
PI0.50.2-120	10mm	13.7mm	50mm	5mm	14.5mm	3mm	2
P12.60.1	12mm	16.5mm	60mm	7mm	14.5mm	3mm	1
P12.60.2-90	12mm	16.5mm	60mm	7mm	14.5mm	3mm	2
P12.60.2-120	12mm	16.5mm	60mm	7mm	14.5mm	3mm	2
P3-8.50.1	3/8"	13.7mm	50mm	5mm	14.5mm	3mm	1
PI-2.60.1	1/2"	16.5mm	60mm	7mm	14.5mm	3mm	1
PI-2.60.2-90	1/2"	16.5mm	60mm	7mm	14.5mm	3mm	2
PI-2.60.2-120	1/2"	16.5mm	60mm	7mm	14.5mm	3mm	2
SPECIAL	L1 LENGTH		PLEASE ENQUIRE				

## CUTTING SPRUE BRUSHINGS

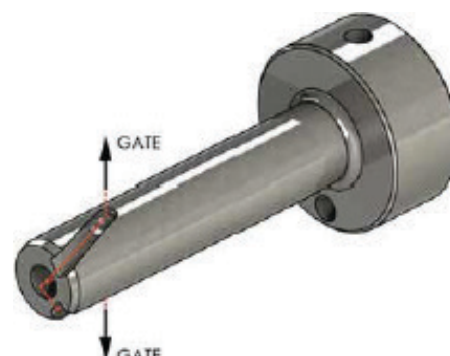
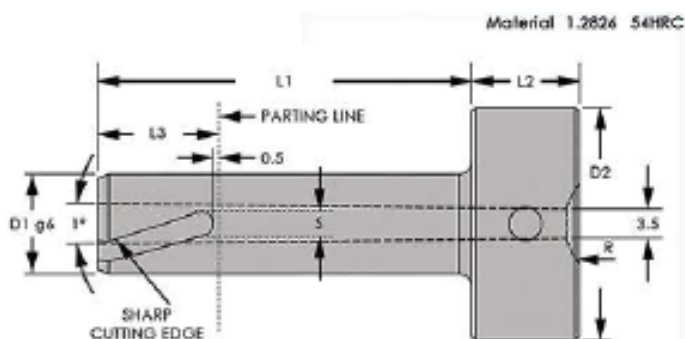

CATALOG NUMBER	D1	D2	L1	L2	L3	S	R
SB 12.56.2.R15.5	12mm	28mm	56mm	13mm	14.5mm	3mm	15.5
SB 12.56.2.R15.5	12mm	28mm	76mm	13mm	14.5mm	3mm	15.5
SB 12.76.2.R15.5	18mm	38mm	60mm	18mm	20.5mm	5mm	15.5
SB 18.60.2.R15.5	18mm	38mm	90mm	18mm	20.5mm	5mm	15.5
SB 18.90.2.R15.5	12mm	28mm	56mm	13mm	14.5mm	3mm	1/2"
SB12.56.2.R12	12mm	28mm	56mm	13mm	14.5mm	3mm	1/2"
SB 18.60.2.R12	18mm	38mm	60mm	18mm	20.5mm	5mm	1/2"
SB 18.90.2.R12	18mm	38mm	60mm	18mm	20.5mm	5mm	1/2"
SPECIAL	L1 LENGTH		PLEASE ENQUIRE				

# ALMO

# INSTALLATION INFO

## PIN

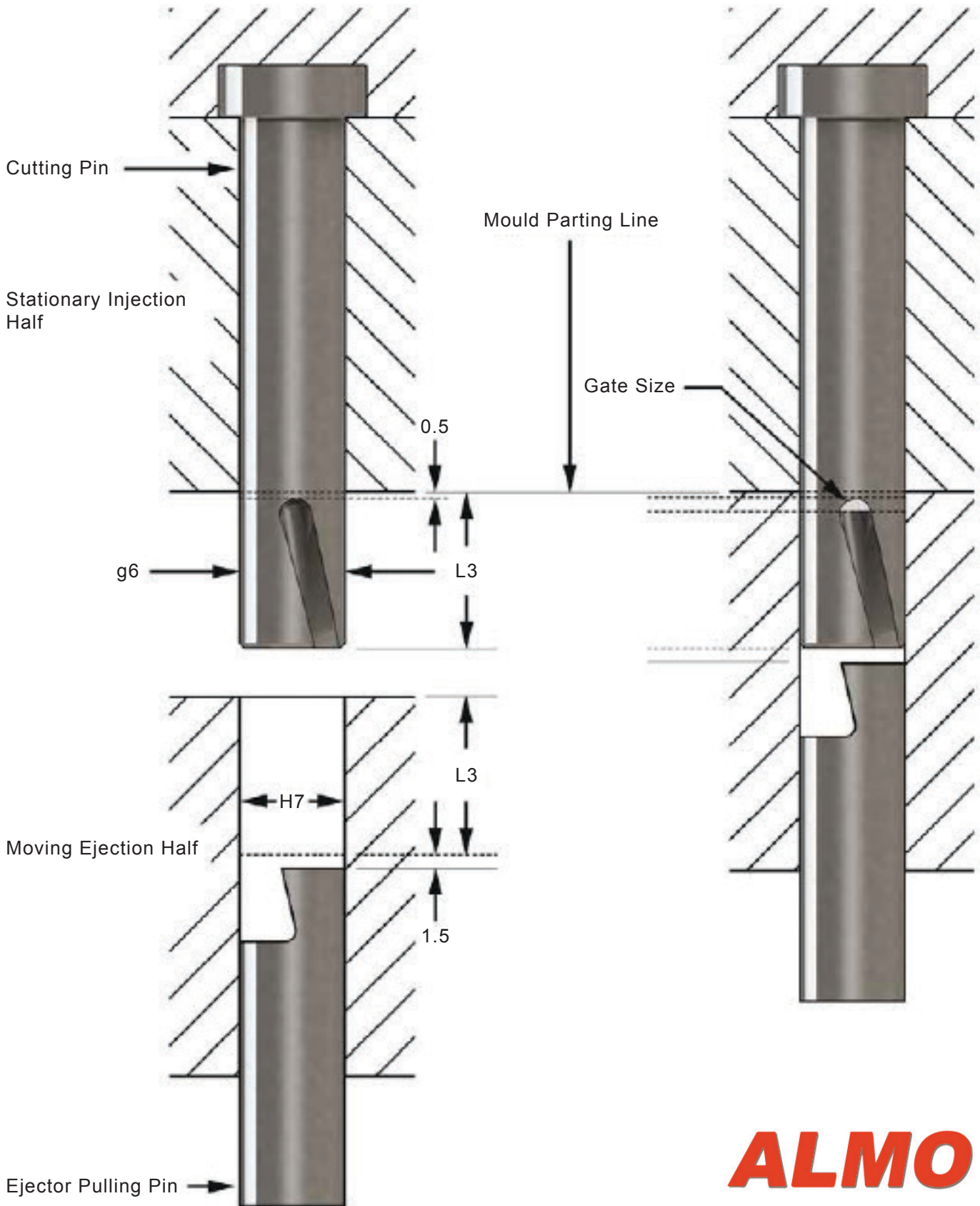

# ALMO

PATENTED PRODUCT

# INSTALLATION INFO

## SPRUE BUSHING

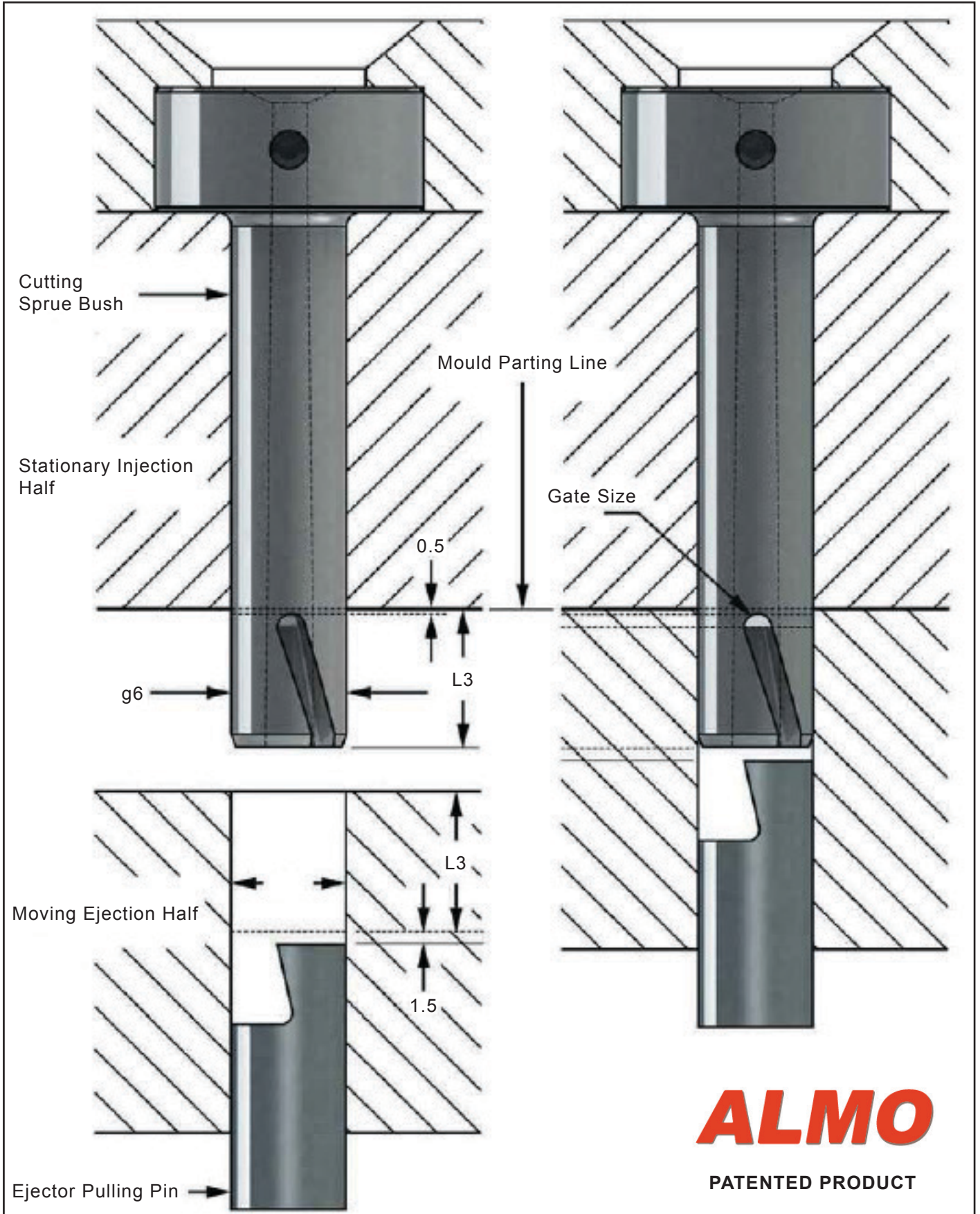

# SLIDE LIFTER UNITS

## ADJUSTABLE

- Three sizes: 3/4", 1", 1-1/4", 1-1/2", 2" and metric sizes
- Other sizes available upon request
- Standard zero degree
- Available in increments of 1 deg up to 10 deg as special order
- Solid bronze slide plate also available
- \*To order solid bronze slide plate, use part number with suffix "NG". Example: UKOCUM075-0-NG



### Slide Lifter Unit - UKOCUM

ITEM NUMBER	D	W	Wa	L	La	***K	Ma	Wb	d	d1	t
UKOCUM075	3/4"	3.0	2.4	3.0	1.2	2.2	3/8"	1.8	11/32"	17/32"	0.4
UKOCUM100	1"	3.2	2.5	3.4	1.5	2.5	3/8"	1.9	11/32"	17/32"	0.4
UKOCUM125	1.25"	3.5	2.8	4.0	2.0	3.0	3/8"	2.2	11/32"	17/32"	0.4

ITEM NUMBER	h	M	***e	E	H	T	G	F	A	a	g	N1	N2
UKOCUM075	0.75	1/2"	5/16"	.35	1.8	1.2	1.0	1.8	1.55	0.63	0.5	25.4	20.6
UKOCUM100	0.75	1/2"	5/16"	.35	1.8	1.4	1.0	2.0	1.80	0.88	0.5	28.5	23.8
UKOCUM125	0.75	1/2"	5/16"	.35	2.2	1.5	1.0	2.4	2.00	1.125	0.6	31.7	26.9

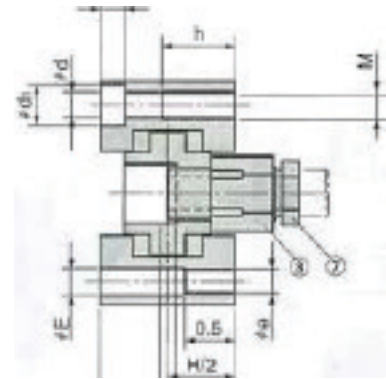
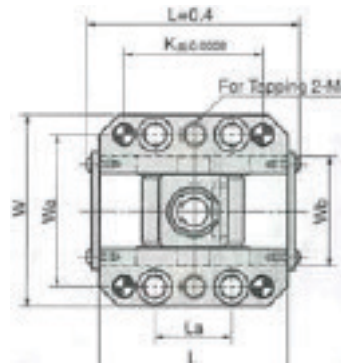
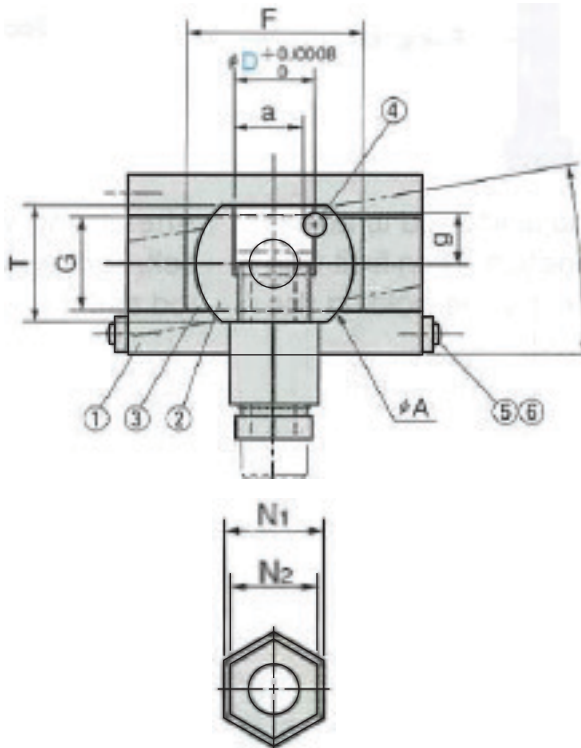

## Table of Components

No.	Description	Qty.	Material and Remark
q	Guide Rail	2	S45C (I C45 A 1045)
w	Inclined Pin Holder	1	S45C (I C45 A 1045)
e	Slide Plate	2	Bronze with Graphite
r	Loosening Lock	1	SK5M
t	Lock Plate	2	SS400 (A A36-89b, A283-88)
y	Round Head Screw	4	SCM435 (I 34CrMo4 A 4137)
u	Adjusting Rod	1	S45C (I C45 A 1045)
i	Lock Nut	1	S45C (I C45 A 1045)

# U COUPLINGS & T-GIBS



## U COUPLINGS

Material: H-13 Steel  
Hardness 38-42 RC

Enquire about Custom Unilifter Blades

### U-COUPLINGS - INCH

SERIES	ITEM NO.	CW	CL	CH	RC	R
0.250	ULCM50	0.500	0.437	0.625	0.125	0.250
0.500	ULCU87	0.875	0.750	0.875	0.187	0.406
1.000	ULCX175	1.750	1.500	1.656	0.125	0.875

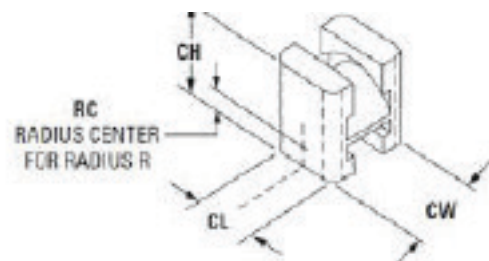

### U-COUPLINGS - METRIC Dimensions in mm

SERIES	ITEM NO.	CW	CL	CH	RC	R
10	ULCMM22	22.00	18.00	25.00	6.00	10

## T-GIBS

Material: H-13 Steel  
Hardness 38-42 RC

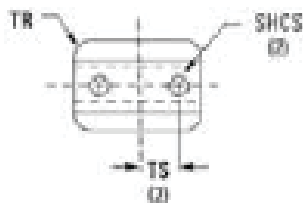

### T-GIBS - INCH Dimensions in mm

SERIES	TW + .000 - .001	TH + .010 - .000	TD* + .010 - .000	TR	SHCS	ITEM NUMBER	TS	TL + .000 - .010	TRAVEL ALLOWED
0.250	0.500	0.500	0.344	0.093	#10-32x1"	ULGM31	CL	0.750	5/16
						ULGM100	0.5	1.500	1"
0.500	0.875	0.468	0.219	0.187	1/4-20x3/4	ULGU25	CL	1.000	1/4
						ULGU50	0.375	1.250	1/2
						ULGU100	0.625	1.750	1"
						ULGU150	0.75	2.250	1-1/2
1.000	1.750	0.615	0.250	0.312	3/8-16x11/4	ULG×50	0.625	2.000	1/2
						ULG×100	0.875	2.500	1"
						ULG×250	1.375	4.000	2 1/2

### T-GIBS - METRIC Dimensions in mm

SERIES	TW + .000 - .025	TH + .25 - .00	TD* + .25 - .00	TR	SHCS	ITEM NUMBER	TS	TL + .00 - .25	TRAVEL ALLOWED
10	22	13	6.00	5	M5 X 20	ULGMM10	10	33	10
						ULGMM30	15	52	30

\*NOTE: Thickness TD is provided with an additional .010" (or .25mm) for final adjustment

# CPLP-PLP PARTING LINE PADS

Customs Available  
Upon Request



Material: 4140-50RC

## CORNER PARTING LINE PAD

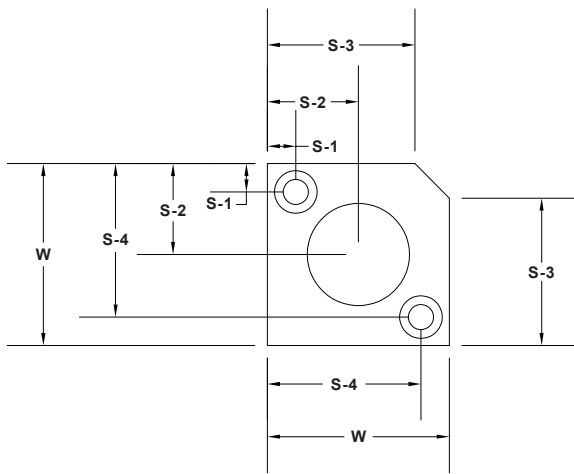

Part#	"T" +.001	"W" -.004 +.008	"S-1"	"S-2"	"S-3"	"S-4"
CPLP-1.0	.480"	2"	0.312	0.5	1.5	1.687
CPLP-1.5	.480"	3"	0.5	0.75	1.5	2.5
CPLP-2.0	.480"	4"	0.075	1	2.5	3.25
CPLP-2.5	.480"	5"	1"	1.25	3.5	4"
CPLP-3.0	.480"	6"	1"	1.5	4.5	5"

CPLP-01

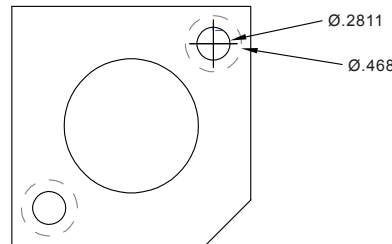

- CPLP-01  
Screw Hole 02811 x 0.468
- CPLP-1.5 to CPLP-3.0  
Screw Hole 02811 x 0.468

## PARTING LINE PAD

Part#	"T" +.001	"W" -.004 +.008	"L" -.004 +.008	"S-1"	"S-2"	"S-3"
PLP-01	.480"	1"	3"	0.75	0.5	1.5
PLP-02	.480"	1-1/2"	3"	0.75	0.75	1.5
PLP-03	.480"	2"	4"	0.75	1	2.5
PLP-04	.480"	2-1/2"	5"	0.75	1.25	3.5
PLP-05	.480"	3"	6"	0.75	1.5	4.5

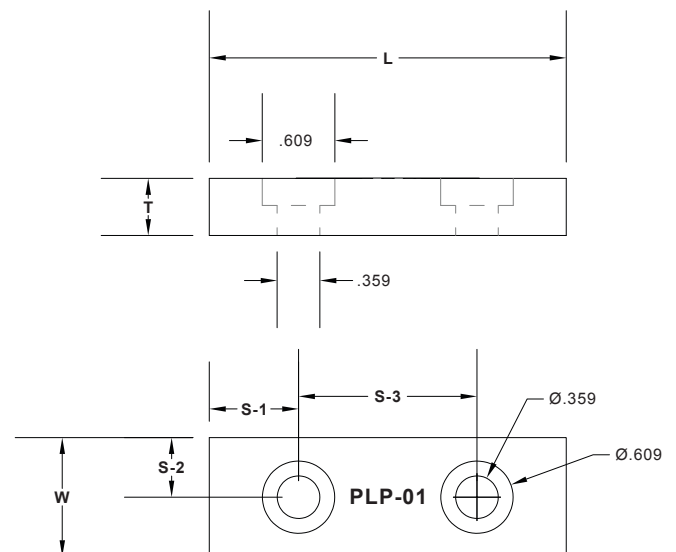

# RHINO FEET & TOES

RHINOFEET™

The Rhino Foot product line helps eliminate the hazards associated with placing molds and plates on wood blocks and pallets.

- Safer, cleaner, and improves 5S standards within the shop.
- 7,000 lbs (3,000 kg) or (15,000 lbs (7,000 kg) Safe working loads with a safety factor of 3.
- Height and load is marked on the feet for easy identification.
- Color - Safety Yellow.

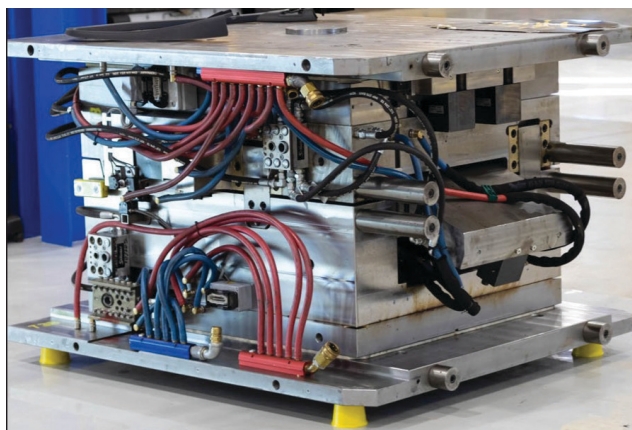
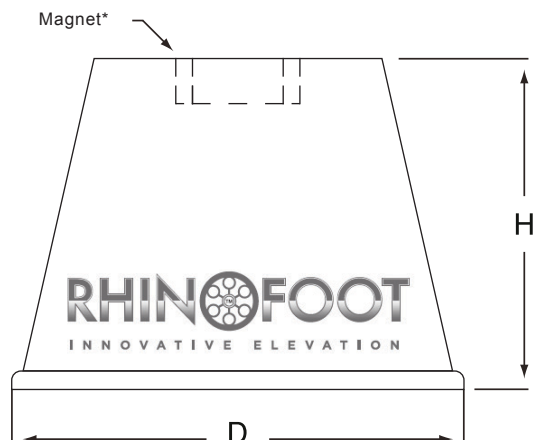

CATALOG NUMBER INCH	CATALOG NUMBER METRIC	D	H	SAFE WORKING LOAD (LBS/KG)
RHF2	RHF50	4.12" / 104mm	2" / 50mm	7,000 / 3,000
RHF3	RHF75	4.12" / 104mm	3" / 75mm	7,000 / 3,000
RHF4	RHF100	4.12" / 104mm	4" / 100mm	7,000 / 3,000
RHF5	RHF125	5.43" / 140mm	5" / 125mm	15,000 / 7,000

\*Note: The RHF5/RHF125 has 2 magnets.

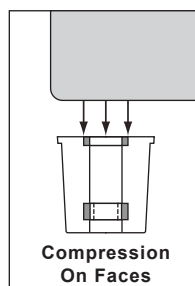
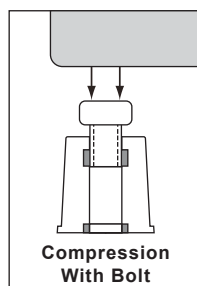
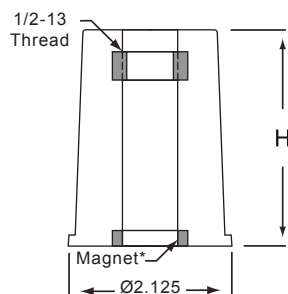

RHINOTOES™



CATALOG NUMBER INCH	H	COMPRESSION WITH BOLT SAFE WORKING LOAD (LBS/KG)	COMPRESSION ON FACES SAFE WORKING LOAD (LBS/KG)
RHT1	1"	630 / 286	2,500 / 1,000
RHT2	2"	800 / 363	2,500 / 1,000
RHT3	3"	830 / 377	2,500 / 1,000

### APPLICATION GUIDELINES

- RhinoToes are utilized to support a plate or hot runner system for bench work or storage.
- Use with a 1/2-13 bolt or threaded rod for additional heights and plate separation.
- Toes have a safety factor of 3.
- Mold maker to supply 1/2-13 threaded rod or bolt.



# RUNNER SHUT-OFFS



(U.S. Patent No. 5,208,053)

Runner Shut-offs are supplied unmachined as shown in background of photo. Foreground shows sample machining of runner, typically done with shut-off installed in mold.

Runner Shut-Offs provide a precise method of blocking or directing material flow to one or more cavities in multi-cavity or family molds.

- > Safer and more positive than the use of brass or ejector pins
- > Reduces scrap and sorting
- > Improves cycle time

## Typical Applications

Shutting Off the Runner to One or More Cavities

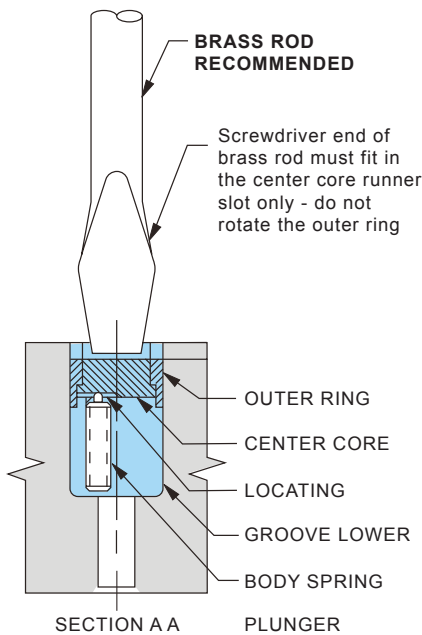

**NOTE:** Spring plunger in Runner Shut-Off Insert engages a locating groove in the center core. This holds the center core in position at each 90° rotation of the center core, thus providing several combinations of runner shut-off positions.

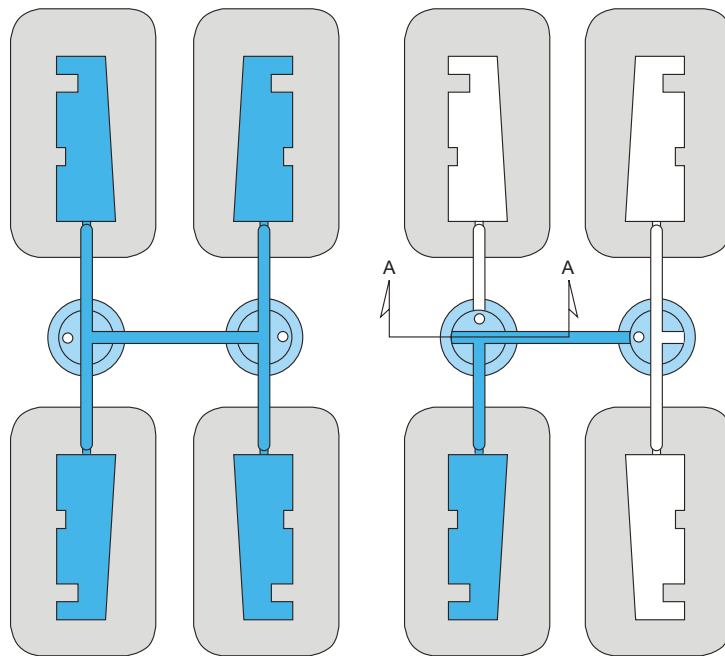

Runner Shut-Offs are shown above in the open position, which allows material to flow to all cavities.

By rotating the center core of the Runner end of a brass rod, material flow to one or several cavities can be shut off, as shown above.

## Runner Shut-Offs - RSO

ITEM NUMBER	ØD	L LENGTH
RSO-13	.5118 (13mm)	.885 (22.5mm)
RSO-16	.6299 (16mm)	.885 (22.5mm)
RSO-26	1.0236 (26mm)	1.260 (32mm)

All dimensions are in inches except for several parenthetical reference dimensions in millimeters.

### INFORMATION KEY:

C = Depth of Runner  
 D = Diameter  
 L = Length  
 R = Radius  
 W = Runner  
 Material: Stainless Steel  
 Hardness: 50 ± 3HRC  
 Max. Temp: 120°C (250°C)  
 Dimensions: All dimensions are in inches, except as noted.

\*Measure ØD in this area only. Top and bottom of insert have a very slight relief for proper installation and operation.

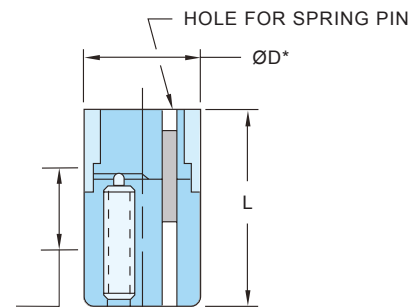

Do not adjust spring plunger. It has been supplied installed to the correct position.

# RUNNER SHUT-OFFS

## MACHINING INFORMATION

### DIMENSIONS FOR MACHINING POCKET FOR RUNNER SHUT-OFFS

- > Pockets are typically bored in soft steel and jig ground in hardened steel
- > Maintain a close tolerance press fit, as specified. Too loose a fit could allow the insert to move out of position, while too tight a press fit might prevent the center core from rotating when required

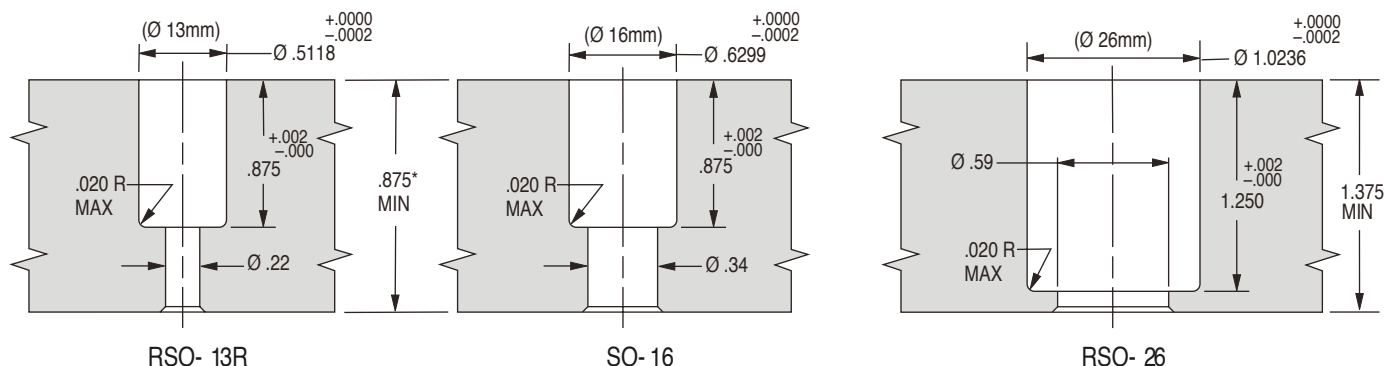

\*When using a 7/8 thick plate with the RSO 0013 or RSO 0016 inserts, machine the .5118 or .6299 diameters through the plate. Inserts must seal against a supporting plate before any grinding or matching is done and during the molding process.

### DIMENSIONS FOR MACHINE RUNNERS

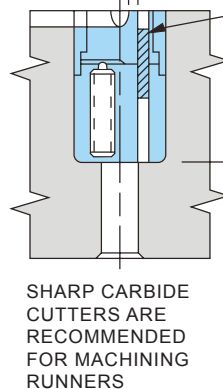
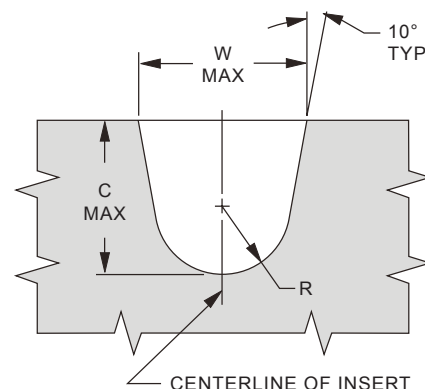
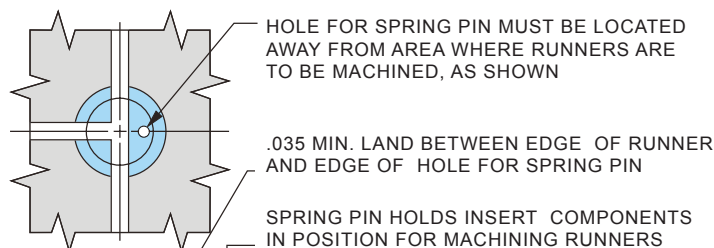

All dimensions are in inches except for some metric dimensions which are shown in parentheses.

RECOMMENDED RUNNER SIZES					
Use Insert Item Number	W MAX	C MAX	R RADIUS	$\varnothing$	AREA S
RSO- 13 (RS)	0.099	0.091	0.040	0.095	0.007
	0.126	0.120	0.050	0.123	0.012
RSO- (RSO-)	0.150	0.131	0.062	0.141	0.016
	0.168	0.144	0.070	0.156	0.019
	0.186	0.157	0.078	0.172	0.023
	0.206	0.175	0.086	0.191	0.029
RSO-	0.260	0.218	0.109	0.239	0.045
	0.298	0.250	0.125	0.274	0.059
	0.334	0.281	0.140	0.308	0.074
	0.372	0.312	0.156	0.342	0.092
	0.410	0.343	0.172	0.377	0.112
	0.446	0.375	0.187	0.411	0.133

**NOTE:** All runners should be machined along the center line of the insert and at 90° to the center line. If this is not done the runners will not align closely when rotated 90° or 180° to shutoff material flow to a cavity. All runners should be machined with inserts installed in the mold.

# SPRUE ADJUSTER

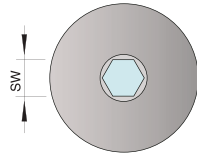
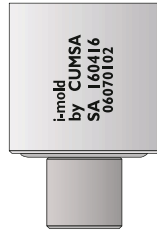
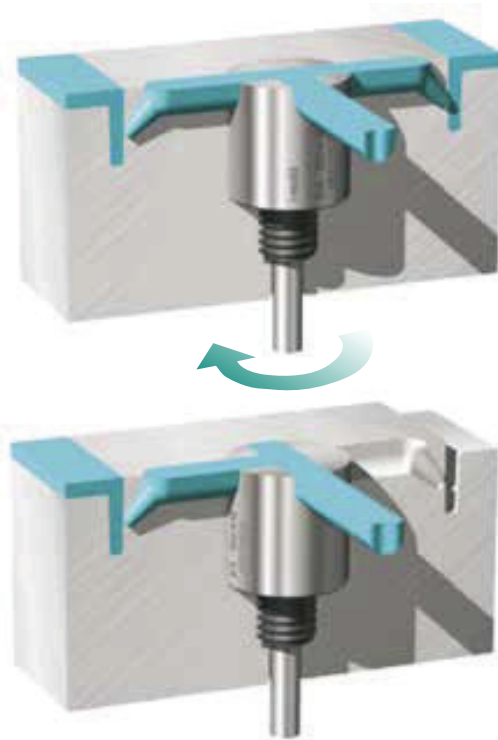

**WITHOUT BORE  
FOR FIXED HALF  
INSTALLATION**

Material:  
1: 1.4034 48 ± 3 HRC  
2: 1.3505 58 ± 2 HRC

Cat. No.	d	d1	L	L1	L3	M	SW
SA120014	12	4	14	5	6	6	3
SA160016	16	5	16	7	8	8	4
SA200018	20	6	18	9	10	10	5

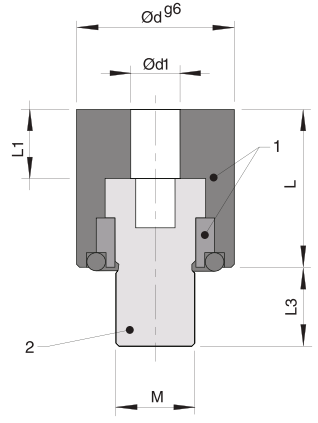

## INSTALLATION EXAMPLES

One Half  
trapezoidal runner

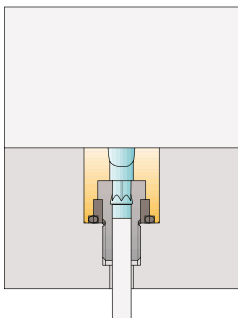

Both Halves  
full round runner

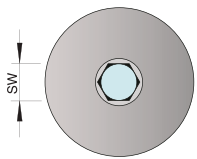
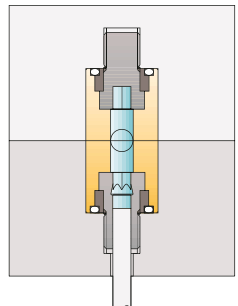

**WITH EJECTOR  
BORE AND  
RETAINER**

Material:  
1: 1.4034 48 ± 3 HRC  
2: 1.3505 58 ± 2 HRC

Cat. No.	d	d1	d2	L	L1	L2	L3	M	SW
SA120314	12	4	3	14	5	6	6	6	3
SA160416	16	5	4	16	7	5	8	8	4
SA200518	20	6	5	18	9	5	10	10	5

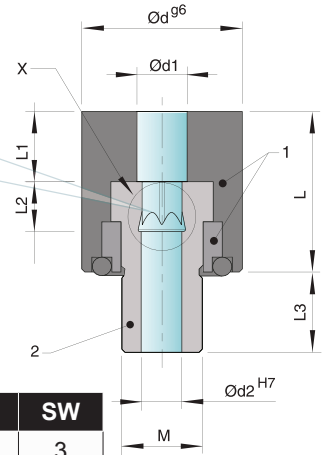
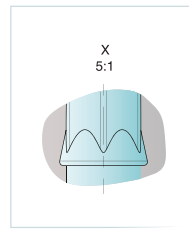

## SPRUE ADJUSTER RANGE OF APPLICATION

Sample: both, left, right, close

Sample: left or right

Sample: open or close

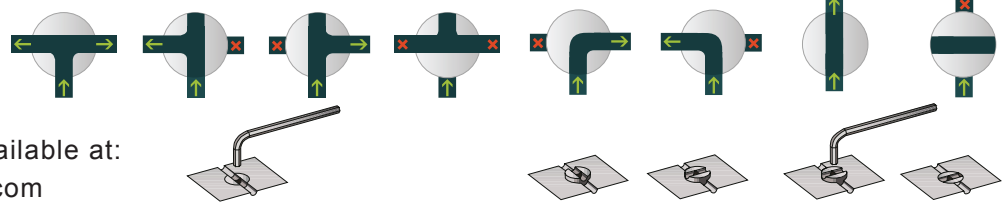

CAD files available at:  
[www.i-mold.com](http://www.i-mold.com)

# CASHEW GATE INSERTS

## S1 SERIES

- With machining allowance on upper surface
- Slight contourings possible
- Same properties as S2 Series
- Available in round (TGR) and square (TGS) versions
- Minimum width of vestige same as S2 Series



**TGR**

**TGS**

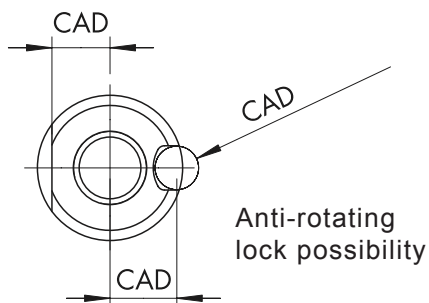

	TGR 6	TGR/TGS 8	TGR/TGS 10	TGR/TGS 12	TGR/TGS 14
GATE POINT	0,6	0,6 / 0,8	0,8 / 1,2 / 1,6	1,2 / 1,6 / 2,0	1,6 / 2,0 / 2,4 / 2,8
RUNNER	2.5	3	4	5	6
MAXIMUM SHOT WEIGHT					
NV	3	5	30	50	200
MV	2	4	20	35	120
HV	1	3	12	25	75



**TGR12**  
ACTUAL SIZE

TGR	Cat. No.	d	d1	d3	h	h1	h2	l1	l2	M	Series	HRC
	TGR6	6	0,6	2.5	17.6	0.6	1.4	10	2.5	4	S1	Version U = 40 HRC* *(available while quantity lasts) Version H = 60 HRC
	TGR8	8	0,6	3	22.6	0.6	1.7	13	3.25	4	S1	
		8	0,8	3	22.6	0.6	1.7	13	3.25	4	S1	
	TGR10	10	0,8	4	22.8	0.8	2.0	12	4	5	S1	
		10	1,2	4	22.8	0.8	2.0	12	4	5	S1	
		10	1,6	4	22.8	0.8	2.0	12	4	5	S1	
	TGR12	12	1,2	5	22.8	0.8	2.2	11	5	5	S1	
		12	1,6	5	22.8	0.8	2.2	11	5	5	S1	
		12	2,0	5	22.8	0.8	2.2	11	5	5	S1	
	TGR14	14	1,6	6	22.8	0.8	2.4	10	6	6	S1	
		14	2,0	6	22.8	0.8	2.4	10	6	6	S1	
		14	2,4	6	22.8	0.8	2.4	10	6	6	S1	
	14	2,8	6	22.8	0.8	2.4	10	6	6	S1		



**TGS12**  
ACTUAL SIZE

TGS	Cat. No.	b	b1	d1	d3	h	h1	h2	l1	l2	M	Series	HRC
	TGS8	8	6	0,6	3	22.6	0.6	1.7	13	3.25	4	S1	Version U = 40 HRC* *(available while quantity lasts) Version H = 60 HRC
		8	6	0,8	3	22.6	0.6	1.7	13	3.25	4	S1	
	TGS10	10	8	0,8	4	22.8	0.8	2.0	12	4	5	S1	
		10	8	1,2	4	22.8	0.8	2.0	12	4	5	S1	
		10	8	1,6	4	22.8	0.8	2.0	12	4	5	S1	
	TGS12	12	10	1,2	5	22.8	0.8	2.2	11	5	5	S1	
		12	10	1,6	5	22.8	0.8	2.2	11	5	5	S1	
		12	10	2,0	5	22.8	0.8	2.2	11	5	5	S1	
	TGS14	14	12	1,6	6	22.8	0.8	2.4	10	6	6	S1	
		14	12	2,0	6	22.8	0.8	2.4	10	6	6	S1	
		14	12	2,4	6	22.8	0.8	2.4	10	6	6	S1	
		14	12	2,8	6	22.8	0.8	2.4	10	6	6	S1	



CAD files available at:  
www.i-mold.com

To order — Cat. No.-d1-Series-HRC. Example: **TGR6-06-S1-U**

# CASHEW GATE INSERTS

## S1 SERIES

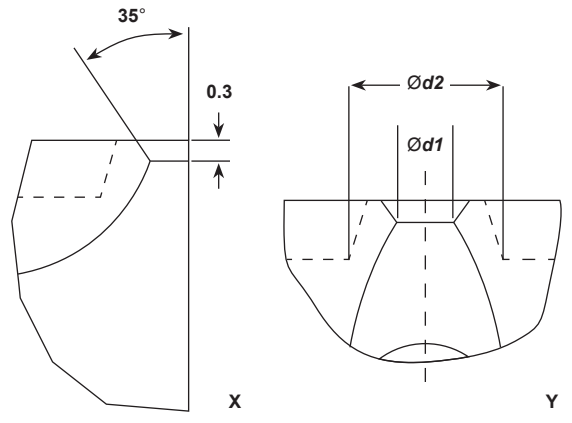
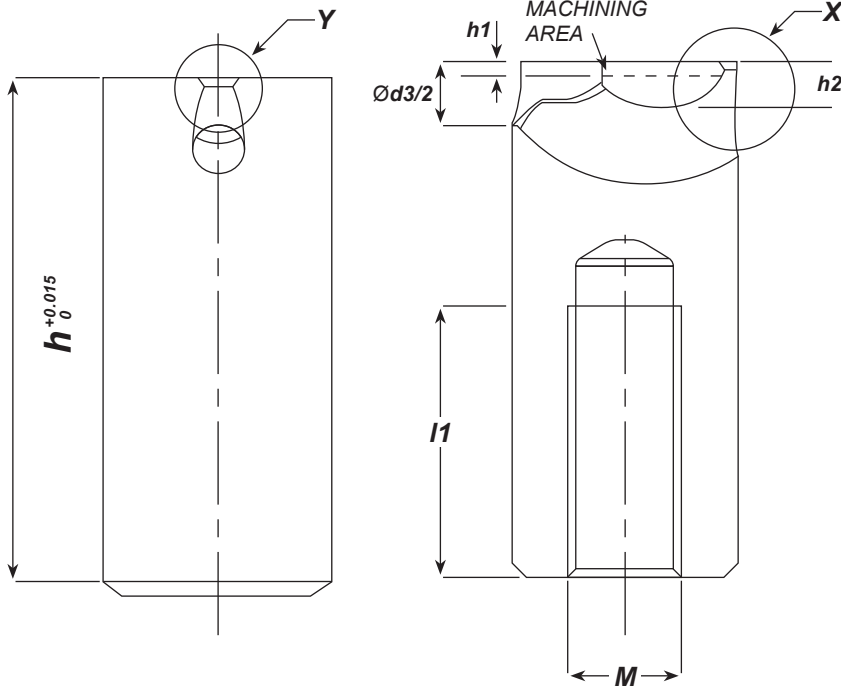

### Thermoplastic elastomers (TPE)

- ▶ Low Shore hardness = shorter distance L
- ▶ Use centring pin
- ▶ Max. hardness 100 Shore A

Table for distance L

Part No.	Material Type			
	TPE, TPU, etc.	PE, PP, PET etc.	PC/ABS, PA, POM, HI-PC, etc.	PA+GF, PC, SAN, PMMA, etc.
TGR 6	9-12	12-18	15-22	18-25
TGR/TGS 8	11-14	15-22	19-27	23-30
TGR/TGS 10	15-18	19-27	24-33	28-36
TGR/TGS 12	18-22	22-30	27-36	32-40
TGR/TGS 14	20-25	25-33	30-37	35-43

### Recommendations

#### Companion Vestige

For optimum degating (especially of flat parts), we recommend the use of a companion vestige supplementing the vestige with cutting edge. This configuration will ensure that the part is separated from the runner flush with the parting line. Users will find this particularly advantageous in cases where materials are susceptible to stringing.

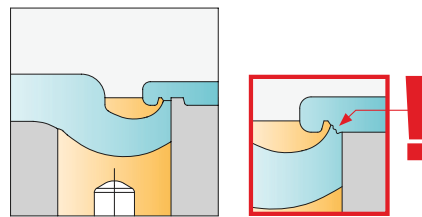

#### Flat Parts

If the molded part is very thin, the calotte must be ground down. ( $t_1 > t/2$ )

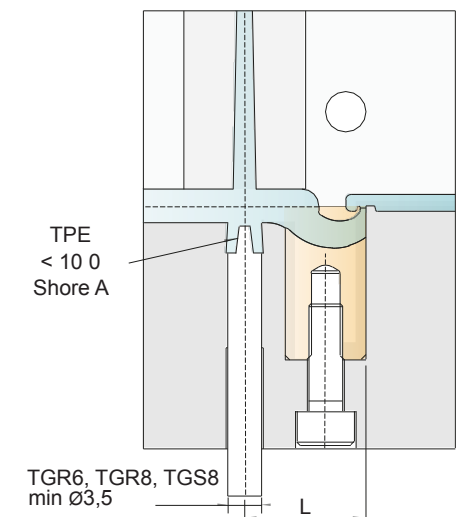
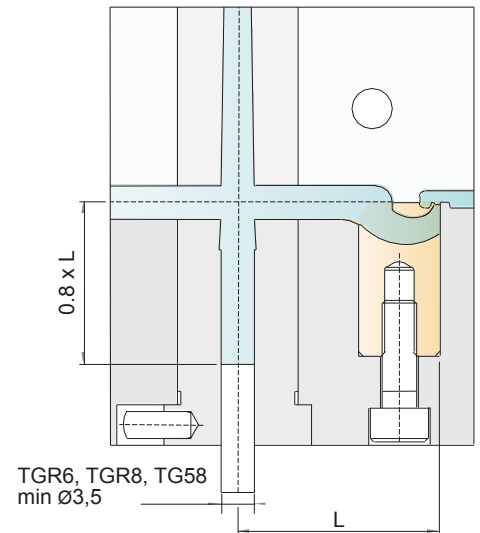
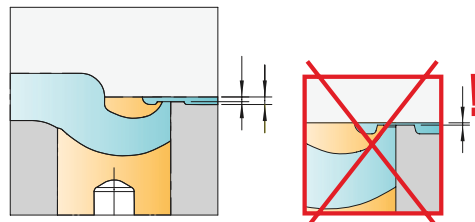

# CASHEW GATE INSERTS

## S2 SERIES

- ▶ With machining allowance on upper surface
- ▶ Slight contourings possible
- ▶ Same properties as S2 Series
- ▶ Available in round (TGR) and square (TGS) versions
- ▶ Minimum width of vestige same as S2 Series



**TGR**

**TGS**

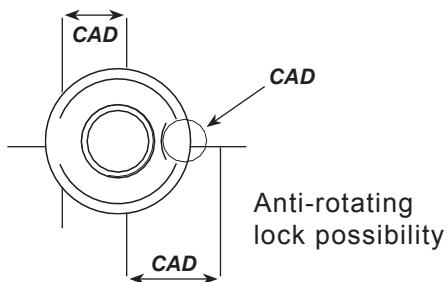

	TGR 6	TGR/TGS 8	TGR/TGS 10	TGR/TGS 12	TGR/TGS 14
GATE POINT	0,6	0,6 / 0,8	0,8 / 1,2 / 1,6	1,2 / 1,6 / 2,0	1,6 / 2,0 / 2,4 / 2,8
RUNNER	2.5	3	4	5	6
MAXIMUM SHOT WEIGHT					
NV	3	5	30	50	200
MV	2	4	20	35	120
HV	1	3	12	25	75



**TGR12**  
ACTUAL SIZE

TGR	Cat. No.	d	d1	d2	d3	h	h1	h2	l1	l2	M	Series	HRC
	TGR6	6	0,6	1.9	2.5	17.0	0.6	0.8	10	2.5	4	S2	Version H = 60 HRC
	TGR8	8	0,6	1.9	3	22.0	0.6	1.1	13	3.25	4	S2	
		8	0,8	2.1	3	22.0	0.6	1.1	13	3.25	4	S2	
	TGR10	10	0,8	2.2	4	22.0	0.8	1.2	12	4	5	S2	
		10	1,2	2.6	4	22.0	0.8	1.2	12	4	5	S2	
	TGR12	12	1,2	2.6	5	22.0	0.8	1.4	11	5	5	S2	
		12	1,6	3.0	5	22.0	0.8	1.4	11	5	5	S2	
		12	2,0	3.4	5	22.0	0.8	1.4	11	5	5	S2	
	TGR14	14	1,6	3.0	6	22.0	0.8	1.6	10	6	6	S2	
		14	2,0	3.4	6	22.0	0.8	1.6	10	6	6	S2	
		14	2,4	3.8	6	22.0	0.8	1.6	10	6	6	S2	
		14	2,8	4.2	6	22.0	0.8	1.6	10	6	6	S2	



**TGS12**  
ACTUAL SIZE

TGS	Cat. No.	b	b1	d2	d3	h	h1	h2	l1	l2	M	Series	HRC
	TGS8	8	6	1.9	3	22.0	0.6	1.1	13	3.25	4	S2	Version H = 60 HRC
		8	6	2.1	3	22.0	0.6	1.1	13	3.25	4	S2	
	TGS10	10	8	2.2	4	22.0	0.8	1.2	12	4	5	S2	
		10	8	2.6	4	22.0	0.8	1.2	12	4	5	S2	
	TGS12	12	10	2.6	5	22.0	0.8	1.4	11	5	5	S2	
		12	10	3.0	5	22.0	0.8	1.4	11	5	5	S2	
	TGS14	12	10	3.4	5	22.0	0.8	1.4	11	5	5	S2	
		14	12	3.0	6	22.0	0.8	1.6	10	6	6	S2	
		14	12	3.4	6	22.0	0.8	1.6	10	6	6	S2	
		14	12	3.8	6	22.0	0.8	1.6	10	6	6	S2	
		14	12	4.2	6	22.0	0.8	1.6	10	6	6	S2	

# CASHEW GATE INSERTS

## S2 SERIES

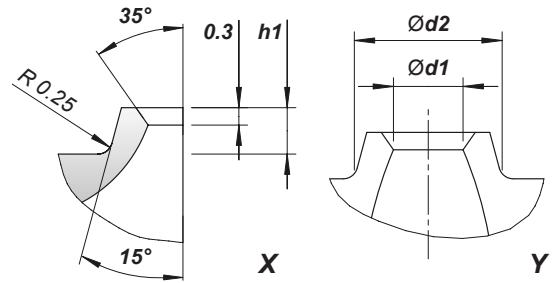
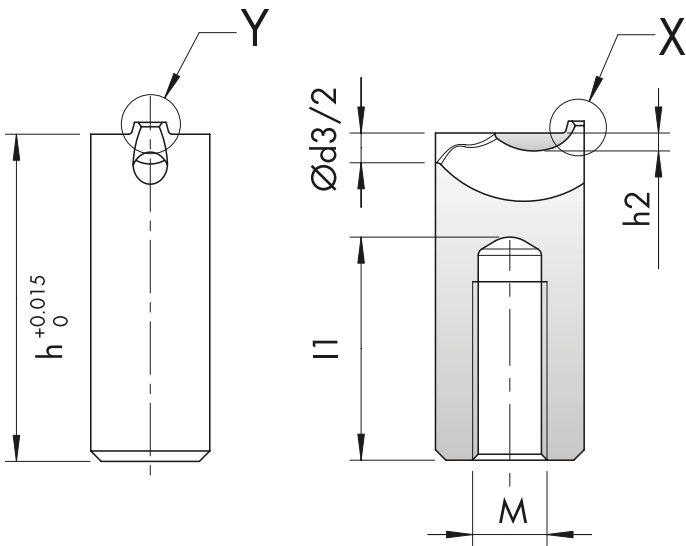

### Thermoplastic elastomers (TPE)

- ▶ Low Shore hardness = shorter distance L
- ▶ Use centring pin
- ▶ Max. hardness 100 Shore A

Table for distance L

Part No.	Material Type			
	TPE, TPU, etc.	PE, PP, PET etc.	PC/ABS, PA, POM, HI-PC, etc.	PA+GF, PC, SAN, PMMA, etc.
TGR 6	9-12	12-18	15-22	18-25
TGR/TGS 8	11-14	15-22	19-27	23-30
TGR/TGS 10	15-18	19-27	24-33	28-36
TGR/TGS 12	18-22	22-30	27-36	32-40
TGR/TGS 14	20-25	25-33	30-37	35-43

### Recommendations

#### Companion Vestige

For optimum degating (especially of flat parts), we recommend the use of a companion vestige supplementing the vestige with cutting edge. This configuration will ensure that the part is separated from the runner flush with the parting line. Users will find this particularly advantageous in cases where materials are susceptible to stringing.

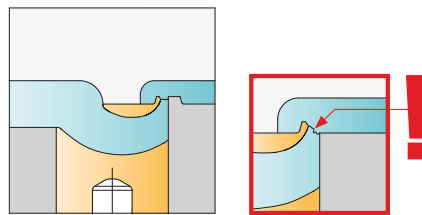

#### Flat Parts

If the molded part is very thin, the calotte must be ground down. ( $t1 > t/2$ )

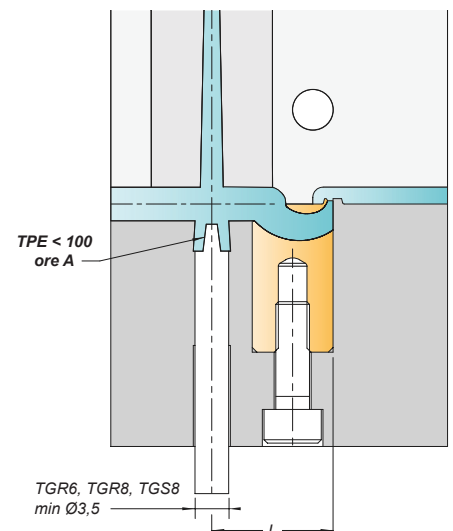
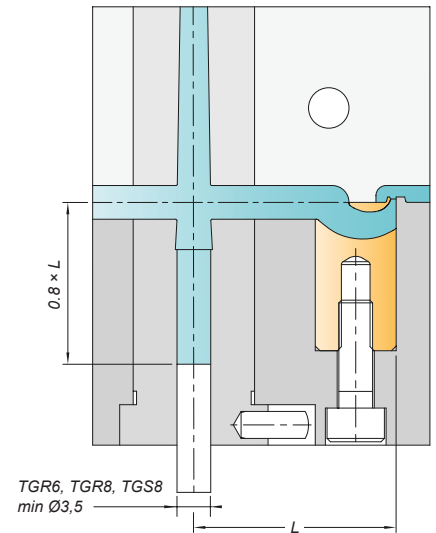
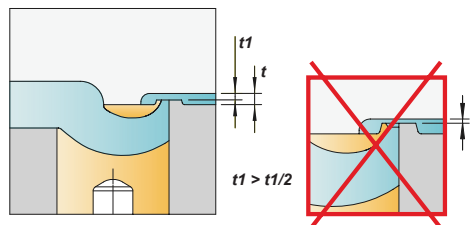

# CASHEW GATE INSERTS

## CONTOURABLE

- For contouring up to 10mm
- Individually adjustable
- Available in 2 degrees of hardness (60 HRC / 40 HRC)

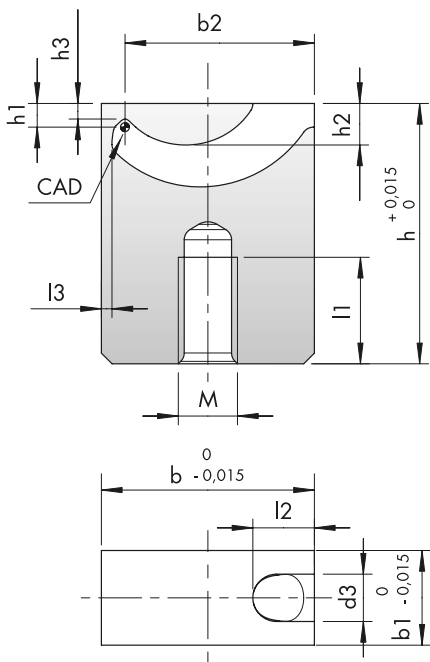

### Vestige Versions

$t1 > t2$  (t = wall thickness of plastic part)

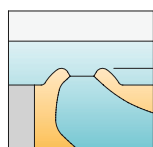

Spherical vestige with cone

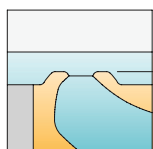

Flattened vestige with cone

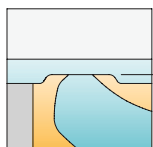

Flattened vestige without cone

## TGC

NV = low viscosity / MV = medium viscosity / HV = high viscosity

	TGC-XS	TGC-S	TGC-1	TGC-2	TGC-3	TGC-4
MAX. CONTOUR DEPTH	1	2	2	3	5	10
GATE POINT	0,4-0,6	0,4 - 0,8	0,6 - 1,2	0,8 - 1,8	0,5x4,5 - 1,5x5,5	0,5x4,5 - 1,5x5,5
RUNNER	2.5	2.5	4	6	8	8
MAXIMUM SHOT WEIGHT						
NV	5	12	35	120	1000	1000
MV	4	7	25	75	500	500
HV	3	5	15	50	300	300

### TGC-XS / TGC-S Mounting Possibilities

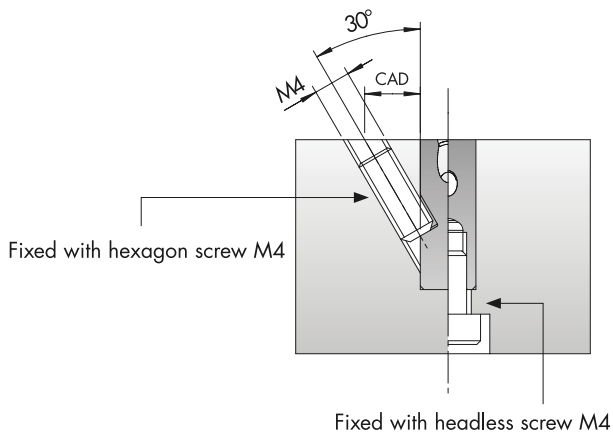

TGC1  
ACTUAL SIZE



CUTAWAY VIEW

Cat. No.	b	b1	b2	d3	h	h1	h2	h3	I1	I2	I3	M	HRC
TGC-XS	10	5	8.5	2.5	12	1	1.9	0.6	5	3.2	0.7	4	Version U = 40 HRC Version H = 60 HRC
TGC-S	15	6	13.3	2.5	18	2	3.5	1.5	8	4	0.9	4	
TGC-1	18	8	16	4	22	2	3.5	1.3	9	5.2	0.9	5	
TGC-2	25	10	22.1	6	22	3	4.8	2.1	8	6.5	1.2	5	
TGC-3	30	12	26.9	8	27	5	7.5	4.1	9	7	1.2	6	
TGC-4	45	12	41.2	8	36	10	16.7	9.1	8	9.6	1.8	6	



CAD files available at:  
www.i-mold.com

To order — Cat. No.-d1-Series-HRC. Example: TGR6-06-S1-U

# CASHEW GATE INSERTS

## CONTOURABLE

### Vestiges — TGC-XS / -S / -1 / -2

Cat. No.	Vestige	h1	d1 max.	dk	Rk	Z
TGC-XS	Standard	1.0	0.6	2.5	1.6	—
TGC-S	Standard	2.0	0.8	2.7	1.7	—
TGC-1	Small	1.8	0.7	2.6	1.4	0.2
	Standard	2.0	1.2	3.5	1.	—
TGC-2	Small	2.75	1.2	3.5	2.0	0.25
	Standard	3.0	1.8	4.5	2.6	—

! - Maintain offset Z from CAD reference point

### Standard Lip Design

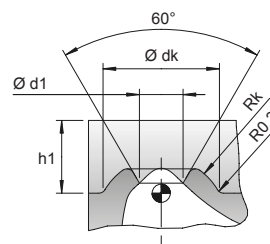

### Small Lip Design

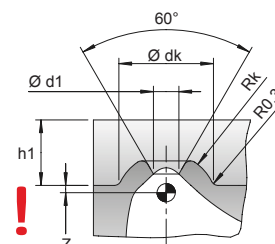

### Vestiges — TGC-3 / -4

#### Standard Lip Design

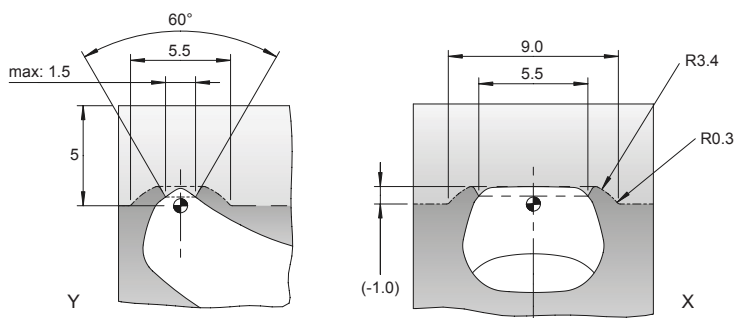

#### Small Lip Design

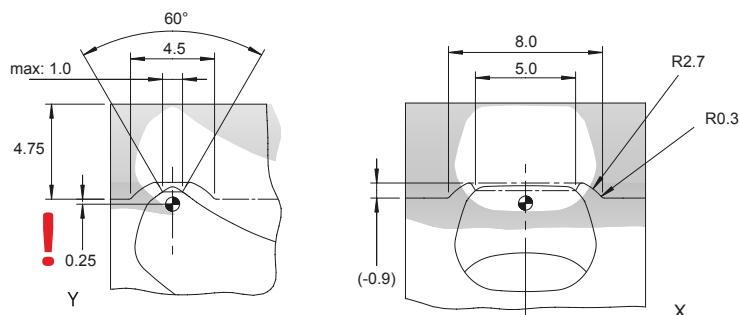
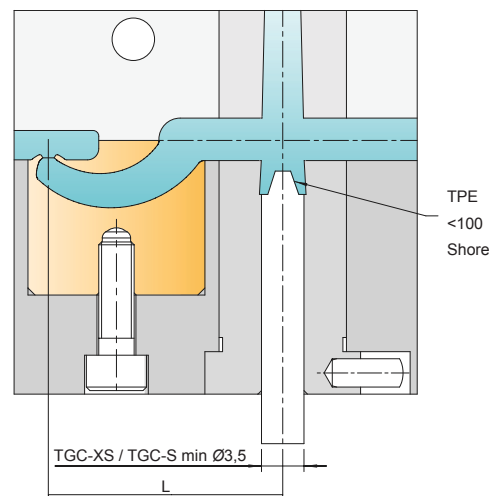
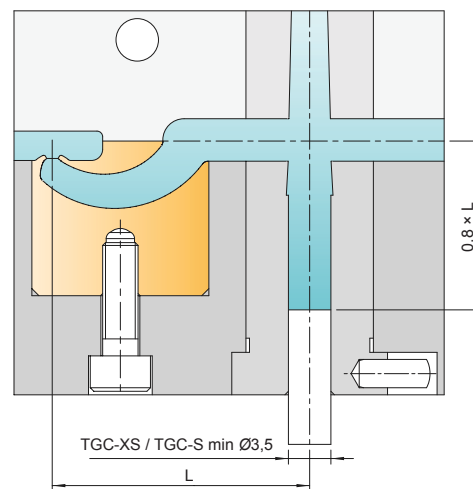

Table for distance L

Catalog Number	Material Type			
	TPE, TPU, etc.	PE, PP, PET, etc.	PC/ABS, PA, POM, HI-PC, etc.	PA+GF, PC, SAN, PMMA, etc.
TGC-XS	12-16	13-20	16-23	22-29
TGC-S	16-21	18-25	21-28	27-34
TGC-1	21-26	26-34	31-39	36-45
TGC-2	28-33	31-39	36-44	41-50
TGC3	33-38	38-48	43-53	48-58
TGC-4	48-53	53-63	58-68	?

### Thermoplastic Elastomers (TPE)

- ▶ Low Shore hardness = shorter distance L
- ▶ Use centring pin
- ▶ Max. hardness 100 Shore A



# SGC CASHEW GATE INSERTS

## SIDE GATE CONTOURABLE

- ▶ Curved tunnel permits getting deep inside the part
- ▶ Integrated dead-end recess reduces loss of pressure and shear stress
- ▶ Highly wear-resistant hot working steel M2 (1.3343) – 54+2 HRC

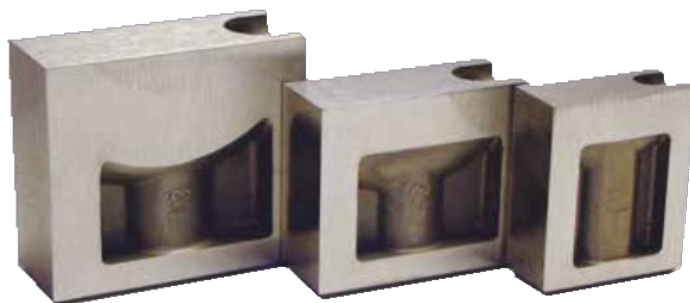

### SGC

	SGC-XS	SGC-S	SGC-1	SGC-2	SGC-3
GATE POINT	0,4 - 0,8	0,4 - 1,0	0,6 - 1,4	0,8 - 2,1	~ Ø 1,1 - 3,3
RUNNER	2.5	2.5	4	6	8
MAXIMUM SHOT WEIGHT					
NV	12	20	35	250	1000
MV	7	12	25	120	500
HV	5	8	15	90	300

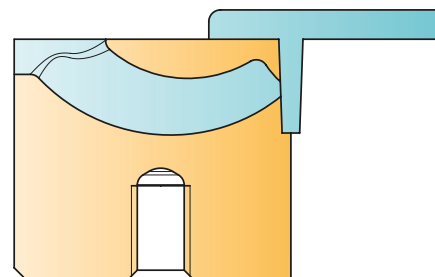

SGC-XS / SGC-S Mounting Possibilities

NV = low viscosity / MV = medium viscosity / HV = high viscosity

Cat. No.	b	b1	b2 max.	d3	h	h1 max.	h2	h3	l1	l2	M
SGC-XS	10	5	1.1	2.5	12	0.6	1.9	2.0	5	3.2	4
SGC-S	15	6	2.0	2.5	18	2	3.5	4.0	8	4	4
SGC-1	18	8	1.8	4	22	2	3.5	4.1	9	5.2	5
SGC-2	25	10	2.5	6	22	2.5	4.8	5.7	8	6.5	5
SGC-3	30	12	2.8	8	27	4.5	7.5	8.4	9	7	6

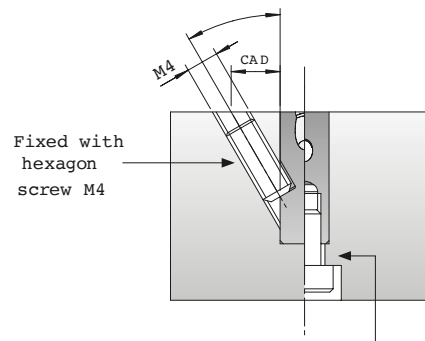

## RETAINING BUSH

### FOR USE WITH CASHEW GATE INSERTS

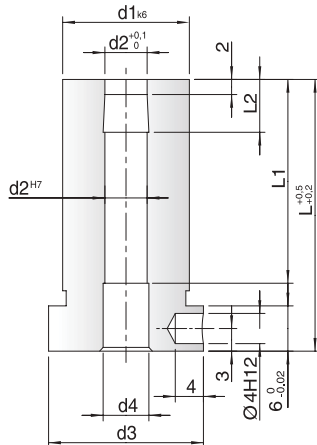

CAT. NO.	L	L1	L2	d1	d2	d3	d4
RB4-36	36	36	7	12	4	16	4.5
RB4-46	46	46					
RB4-56	56	46					
RB6-36	36	36	7	18	6	22	6.5
RB6-46	46	46					
RB6-56	56	56					
RB6-66	66	66	9.5	24	8	28	8.5
RB8-46	46	46					
RB8-56	56	56					
RB8-66	66	66					

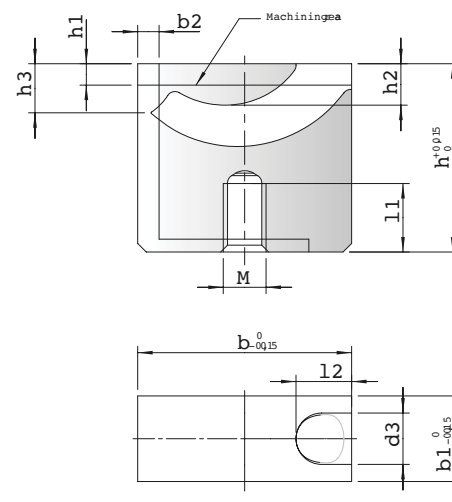
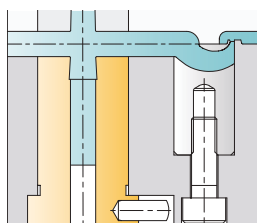

CAD files available at:  
www.i-mold.com



# SGC CASHEW GATE INSERTS

SIDE GATE CONTOURABLE

## SGC-SX

A (mm <sup>2</sup> )	~O (mm)	b2 (mm)
0.13	0.4	0.9
0.3	0.6	1.0
0.53	0.8	1.1

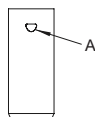

## SGC-S

A (mm <sup>2</sup> )	~O (mm)	b2 (mm)
0.15	0.4	1.7
0.33	0.6	1.8
0.55	0.8	1.9
0.79	1.0	2.0

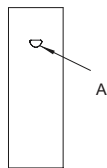

## SGC-1

A (mm <sup>2</sup> )	~O (mm)	b2 (mm)
0.28	0.6	1.4
0.53	0.8	1.5
0.82	1	1.6
1.15	1.2	1.7
1.52	1.4	1.8

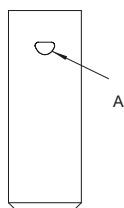

## SGC-2

A (mm <sup>2</sup> )	~O (mm)	b2 (mm)
0.28	0.6	1.7
0.54	0.8	1.8
0.84	1	1.9
1.2	1.2	2
1.57	1.4	2.1
2	1.6	2.2
2.43	1.75	2.3
2.9	1.9	2.4
3.4	2.1	2.5

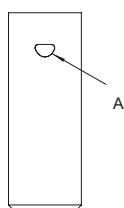

## SGC-3

A (mm <sup>2</sup> )	~O (mm)	b2 (mm)
1	1.1	2
1.75	1.5	2.1
2.56	1.8	2.2
3.43	2.1	2.3
4.35	2.35	2.4
5.32	2.6	2.5
6.33	2.85	2.6
7.38	3	2.7
8.48	3.3	2.8

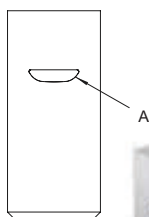

## Thermoplastic Elastomers (TPE)

- ▶ Low Shore hardness = shorter distance L
- ▶ Use centring pin
- ▶ Max. hardness 100 Shore A

Standard installation for shallow and medium contour depths

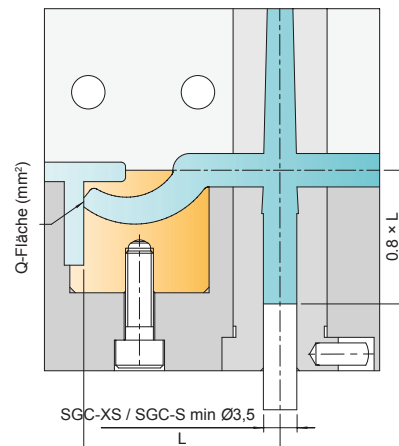

Special installation for deep contours

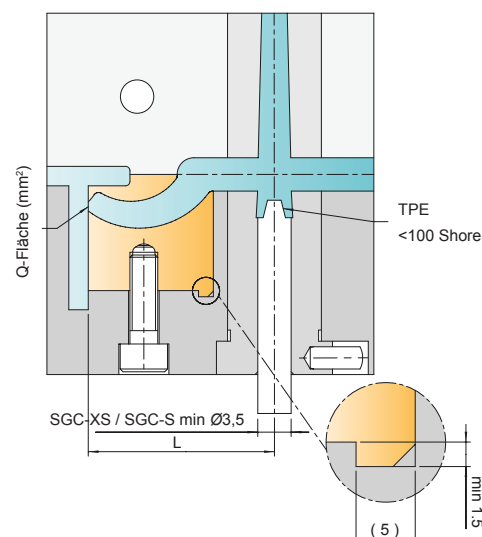

Table for distance L

Catalog Number	Material Type			
	TPE, TPU, etc.	PE, PP, PET etc.	PC/ABS, PA, POM, HI-PC, etc.	PA+GF, PC, SAN, PMMA, etc.
SGC-XS	12-16	13-20	16-23	22-29
SGC-S	16-21	18-25	21-28	27-34
SGC-1	21-26	26-34	31-39	36-45
SGC-2	28-33	31-39	36-44	41-50
SGC3	33-38	38-48	43-53	48-58

# CASHEW GATE INSERTS

MINIFLOW — GTM

Catalog Number	b1	b2	d2	d4	M	Viscosity		
						high flowability	regular flowability	low flowability
GTM-10-05	10	5	0,5	3	3	4	4	3
GTM-10-07	10	5	0,7	3	3	6	5	4
GTM-10-09	10	5	0,9	3	3	12	9	7
GTM-10-11	10	5	1,1	3	3	17	14	9
Weight in grams								



ACTUAL SIZE

EXTERNAL VIEW

CUTAWAY VIEW

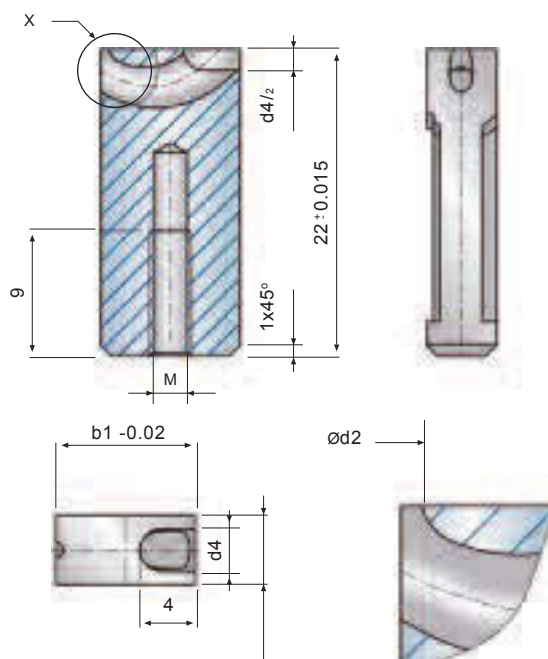

- For gating of small, thin walled parts.
- This insert does not have a raised lip (calotte).
- Suitable for very thin-walled parts.
- Usable for all thermoplastics including fillers up to 50% glass.
- All inserts have the gate diameter 'd2' molded into them.

## Installation Example

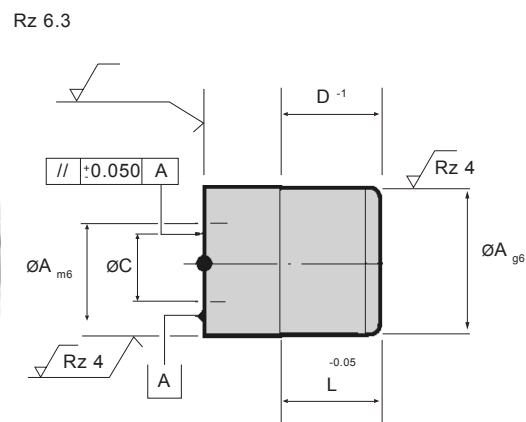
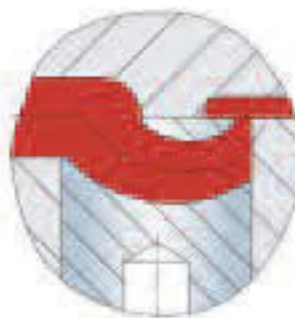
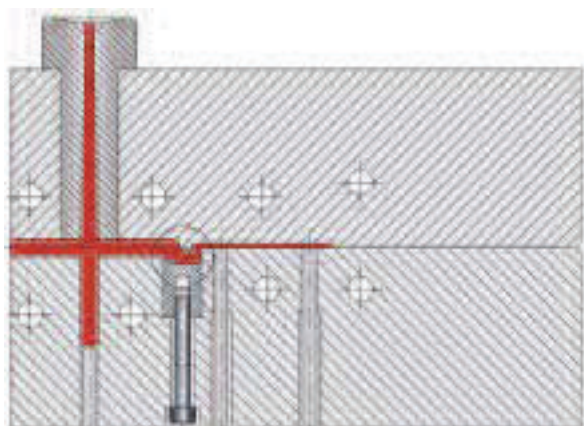

### Thin-Walled Miniflow

Designed for particularly thin-walled parts (0,5 to 1,2 mm wall thickness).

The insert has no raised lip (calotte). Gating will occur flush with the molding.

- The gating point will be flush with, or slightly projecting from, the bottom surface depending on the plastic used.

CAD files available at:  
www.extraflow.com



# CASHEW GATE INSERTS

Ø 14mm — FOR SHOT WEIGHTS UP TO 100g

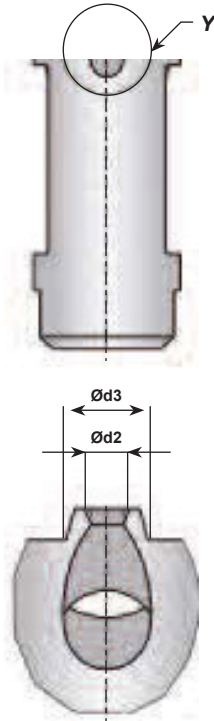
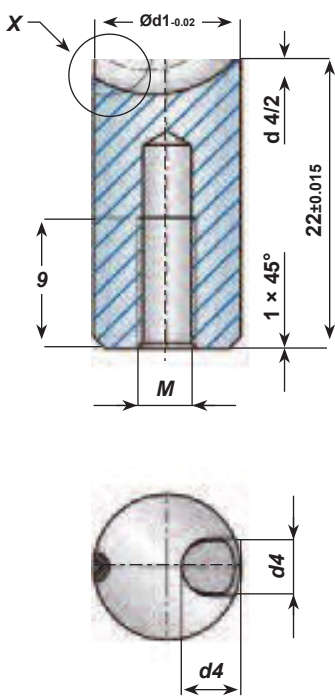

ACTUAL SIZE

EXTERNAL VIEW

CUTAWAY VIEW

- ▶ Manufactured in a solid one-piece unit using the Metal Injection Molding (MIM) process.
- ▶ Optimal balancing of cavity filling due to the exactness of MIM.
- ▶ Hardened to 60HRC and polished.
- ▶ Anti-rotation locking molded into all round inserts. However in most cases the insert is adequately held by the capscrew.

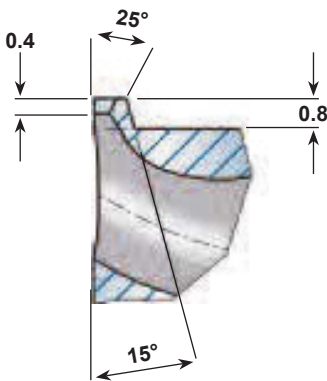

Catalog Number	d1	d2	d3	d4	M	Viscosity		
						high flowability	regular flowability	low flowability
GTR-14-12	14	1,2	2,5	6	6	20	16	10
GTR-14-14	14	1,4	2,7	6	6	30	23	15
GTR-14-16	14	1,6	2,9	6	6	40	30	20
GTR-14-18	14	1,8	3,1	6	6	54	40	27
GTR-14-20	14	2,0	3,3	6	6	68	52	34
GTR-14-22	14	2,2	3,5	6	6	85	65	43
GTR-14-24	14	2,4	3,7	6	6	100	80	50

Weight in grams

## Installation Example

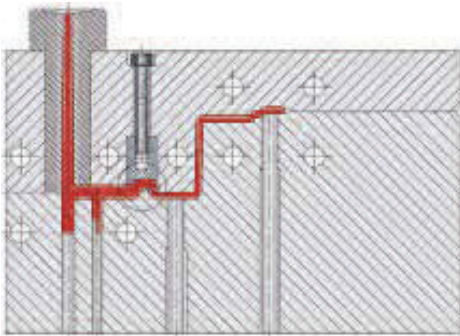

## Anti-Rotation Locking Dimensions

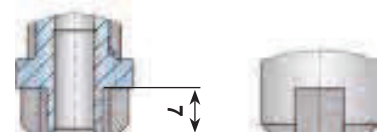
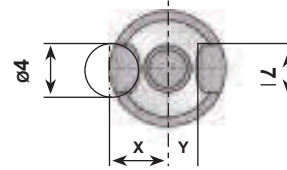

## Nozzle Side Installation

The cashew gate insert is screwed into the nozzle side of the mold. The front of the gate insert is sealed off by the cavity.

- ▶ to reduce pressure loss
- ▶ to minimize shear

Catalog Series	Parallel Pin distance 'X'	Key distance 'Y'
GTR-14	6,0 mm	4,5 mm

CAD files available at:  
www.extraflow.com



# CASHEW GATE INSERTS

14mm — FOR SHOT WEIGHTS UP TO 100g

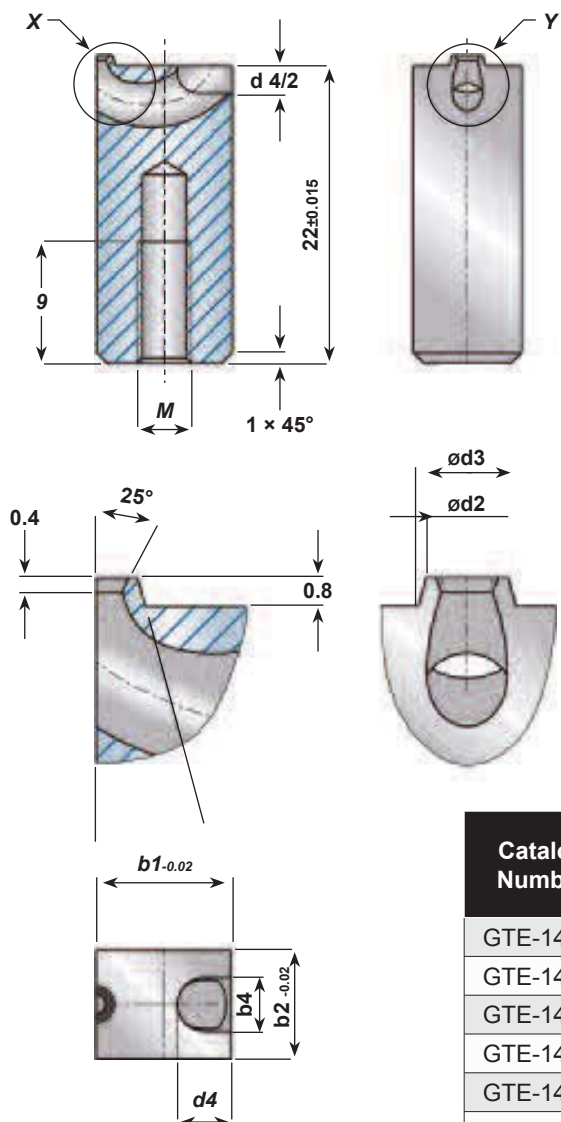

ACTUAL SIZE



EXTERNAL VIEW



CUTAWAY VIEW

- › Manufactured in a solid one-piece unit using the Metal Injection Molding (MIM) process.
- › Optimal balancing of cavity filling due to the exactness of MIM.
- › Hardened to 60HRC and polished.
- › Ideal for thin wall parts.

Catalog Number	b1	b2	d2	d3	d4	M	Viscosity		
							high flowability	regular flowability	low flowability
GTE-14-12	14	12	1,2	2,5	6	6	20	16	10
GTE-14-14	14	12	1,4	2,7	6	6	30	23	15
GTE-14-16	14	12	1,6	2,9	6	6	40	30	20
GTE-14-18	14	12	1,8	3,1	6	6	54	40	27
GTE-14-20	14	12	2,0	3,3	6	6	68	52	34
GTE-14-22	14	12	2,2	3,5	6	6	85	65	43
GTE-14-24	14	12	2,4	3,7	6	6	100	80	50
							Weight in grams		

## Installation Example

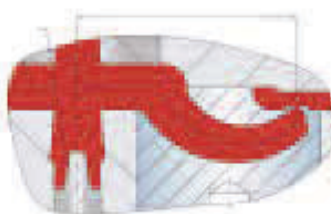
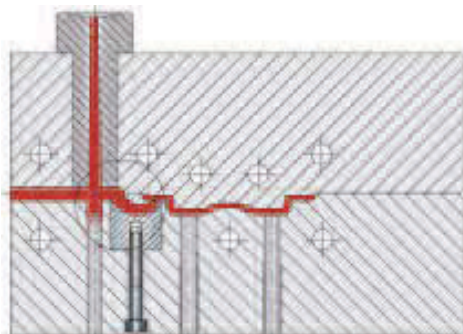

All inserts have the gate diameter 'd2' molded into them.



## Thermoplastic Elastomers

When processing thermoplastic elastomers, please observe the following recommendations to ensure reliable de-molding.

- › the distance 'L' should decrease with the Shore hardness value
- › a centering cone should be used
- › this installation example applies to elastomers in the medium Shore hardness range (up to 100 Shore A)

CAD files available at:  
www.extraflow.com



# CASHEW GATE INSERTS

12mm — FOR SHOT WEIGHTS UP TO 68g

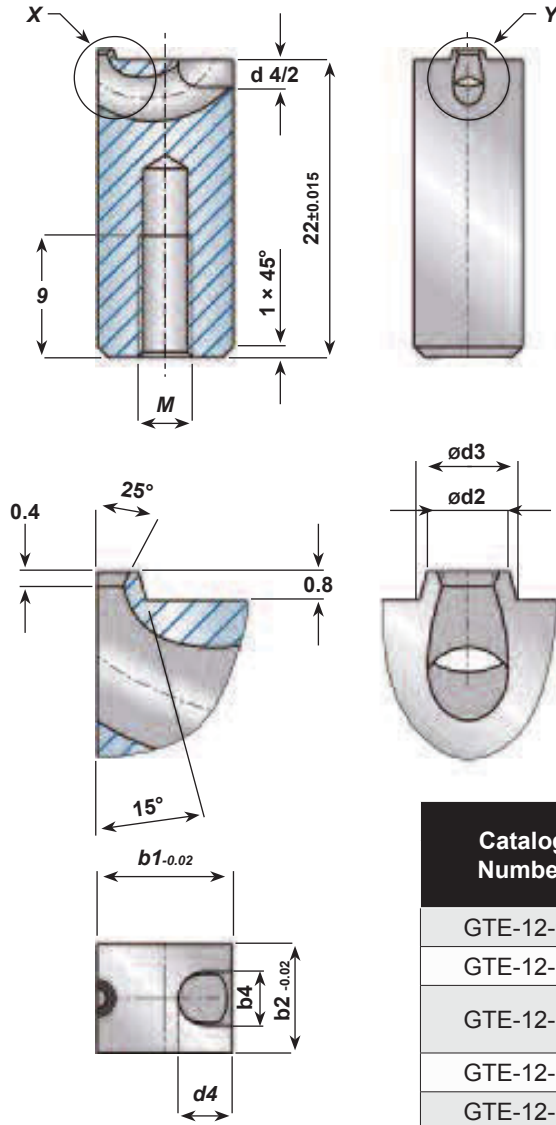

- ACTUAL SIZE
- EXTERNAL VIEW
- CUTAWAY VIEW
- > Manufactured in a solid one-piece unit using the Metal Injection Molding (MIM) process.
- > Optimal balancing of cavity filling due to the exactness of MIM.
- > Hardened to 60HRC and polished.
- > Ideal for thin wall parts.

Catalog Number	b1	b2	d2	d3	d4	M	Viscosity		
							high flowability	regular flowability	low flowability
GTE-12-08	12	10	0,8	2,1	5	5	8	7	5
GTE-12-10	12	10	1,0	2,3	5	5	14	12	9
GTE-12-12	12	10	1,2	2,5	5	5	20	16	10
GTE-12-14	12	10	1,4	2,7	5	5	30	23	15
GTE-12-16	12	10	1,6	2,9	5	5	40	30	20
GTE-12-18	12	10	1,8	3,1	5	5	54	40	27
GTE-12-20	12	10	2,0	3,3	5	5	68	52	34
							Weight in grams		

## Installation Example

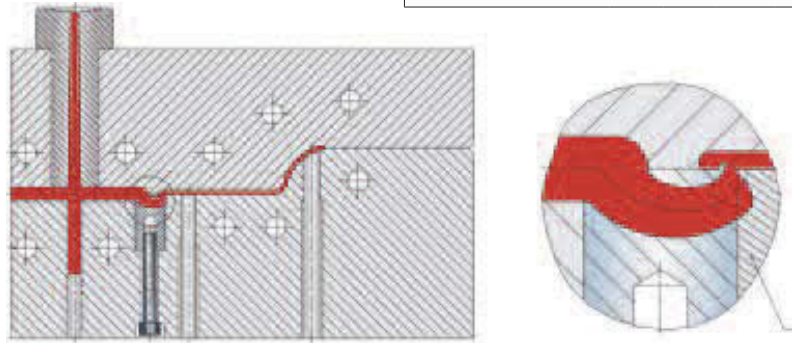

All inserts have the gate diameter 'd2' molded into them.

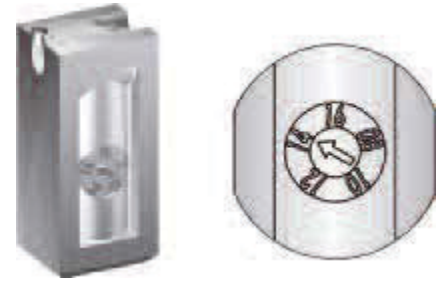

## Thin Walled Parts

The raised lip (calotte) height can be reduced to a maximum of 0.4mm. This is the level of the defined stall edge. The front of the gate insert is sealed off by the cavity to the level of the parting line.

- > to reduce pressure loss
- > to minimize shear

CAD files available at: [www.extraflow.com](http://www.extraflow.com)

# CASHEW GATE INSERTS

Ø 12mm — FOR SHOT WEIGHTS UP TO 68g

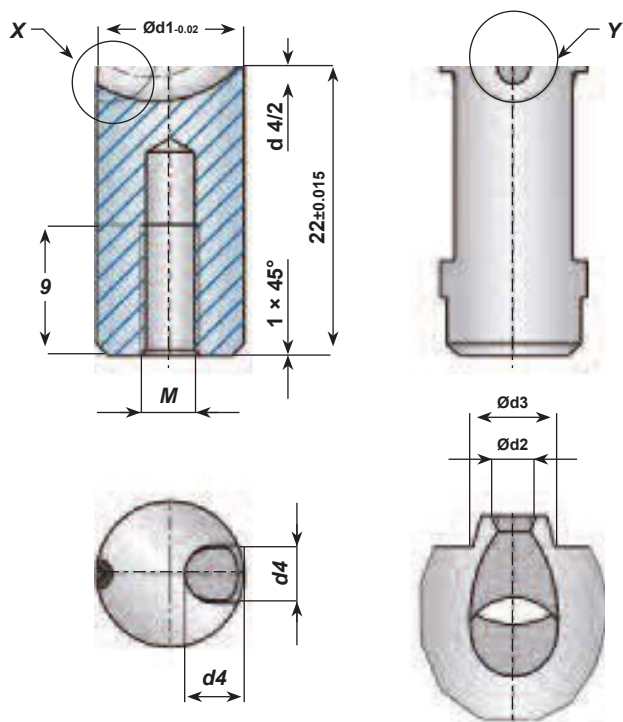

ACTUAL SIZE      EXTERNAL VIEW      CUTAWAY VIEW

- > Manufactured in a solid one-piece unit using the Metal Injection Molding (MIM) process.
- > Optimal balancing of cavity filling due to the exactness of MIM.
- > Hardened to 60HRC and polished.
- > Anti-rotation locking molded into all round inserts. However in most cases the insert is adequately held by the capscrew.

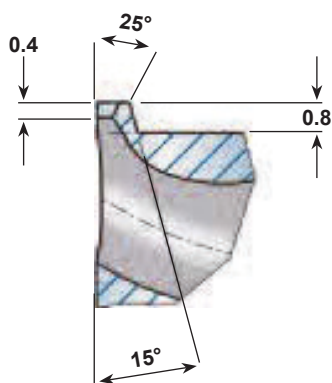

Catalog Number	d1	d2	d3	d4	M	Viscosity		
						high flowability	regular flowability	low flowability
GTR-12-08	12	0,8	2,1	5	5	8	7	5
GTR-12-10	12	1,0	2,3	5	5	14	12	9
GTR-12-12	12	1,2	2,5	5	5	20	16	10
GTR-12-14	12	1,4	2,7	5	5	30	23	15
GTR-12-16	12	1,6	2,9	5	5	40	30	20
GTR-12-18	12	1,8	3,1	5	5	54	40	27
GTR-12-20	12	2,0	3,3	5	5	68	52	34
						Weight in grams		

## Installation Example

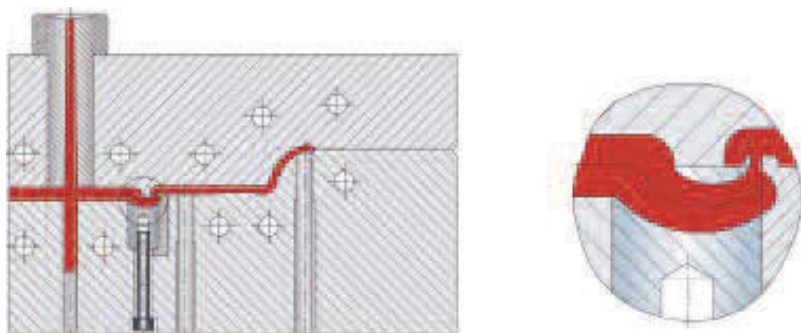

### Flat Parts

The front of the cashew gate insert is fully sealed off by a companion raised lip (calotte) machined into the dead-end insert.

- > to reduce pressure loss
- > to minimize shear

## Anti-Rotation Locking Dimensions

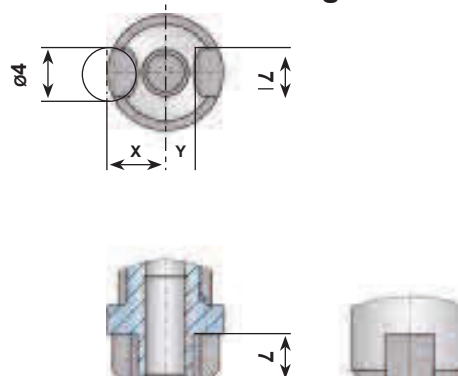

Catalog Series	Parallel Pin distance 'X'	Key distance 'Y'
GTR-12	5,2 mm	3,8 mm

CAD files available at:  
www.extraflow.com



# CASHEW GATE INSERTS

10mm — FOR SHOT WEIGHTS UP TO 40g

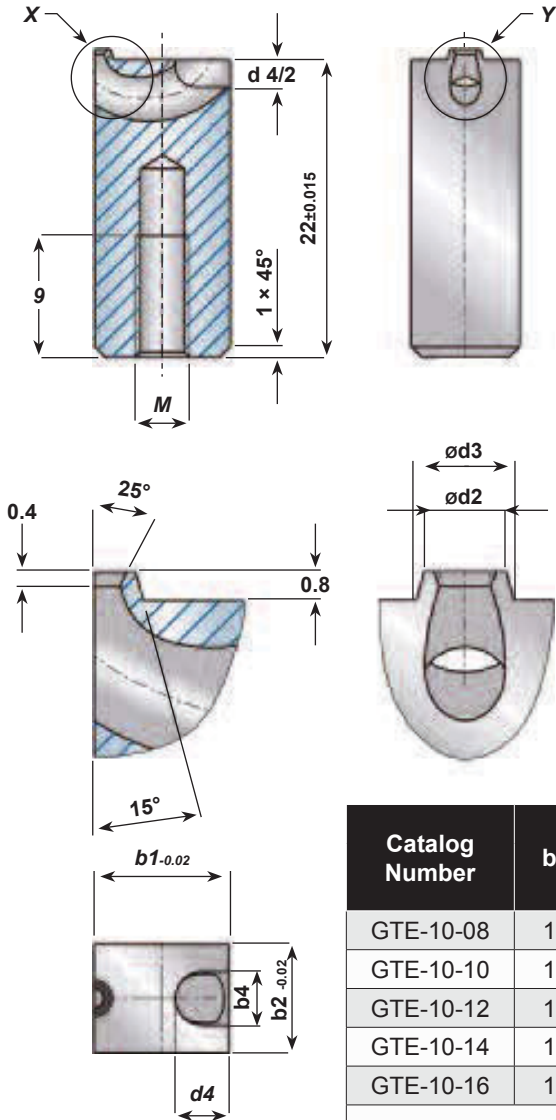

ACTUAL SIZE

EXTERNAL VIEW

CUTAWAY VIEW

- › Manufactured in a solid one-piece unit using the Metal Injection Molding (MIM) process.
- › Optimal balancing of cavity filling due to the exactness of MIM.
- › Hardened to 60HRC and polished.
- › Ideal for thin wall parts.

Catalog Number	b1	b2	d2	d3	d4	M	Viscosity		
							high flowability	regular flowability	low flowability
GTE-10-08	10	8	0,8	2,1	4	4	8	7	5
GTE-10-10	10	8	1,0	2,3	4	4	14	12	9
GTE-10-12	10	8	1,2	2,5	4	4	20	16	10
GTE-10-14	10	8	1,4	2,7	4	4	30	23	15
GTE-10-16	10	8	1,6	2,9	4	4	40	30	20
							Weight in grams		

## Installation Example

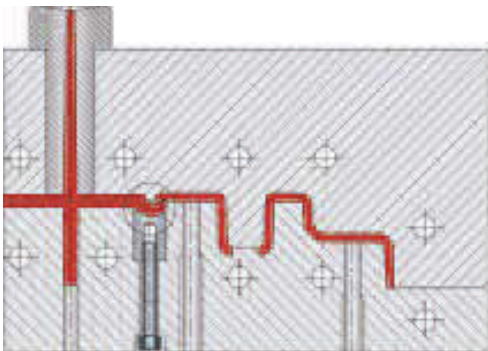

All inserts have the gate diameter 'd2' molded into them.



## Thin Walled Parts

The raised lip (calotte) height can be reduced to a maximum of 0.4mm. This is the level of the defined stall edge. The front of the gate insert is sealed off by the cavity to the level of the parting line.

- › to reduce pressure loss
- › to minimize shear

CAD files available at:  
www.extraflow.com



# CASHEW GATE INSERTS

Ø 10mm — FOR SHOT WEIGHTS UP TO 40g

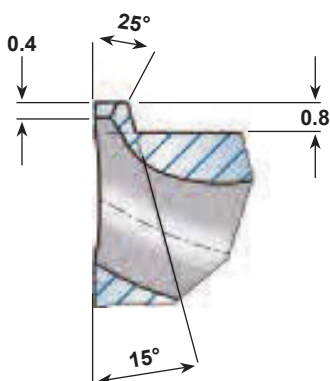
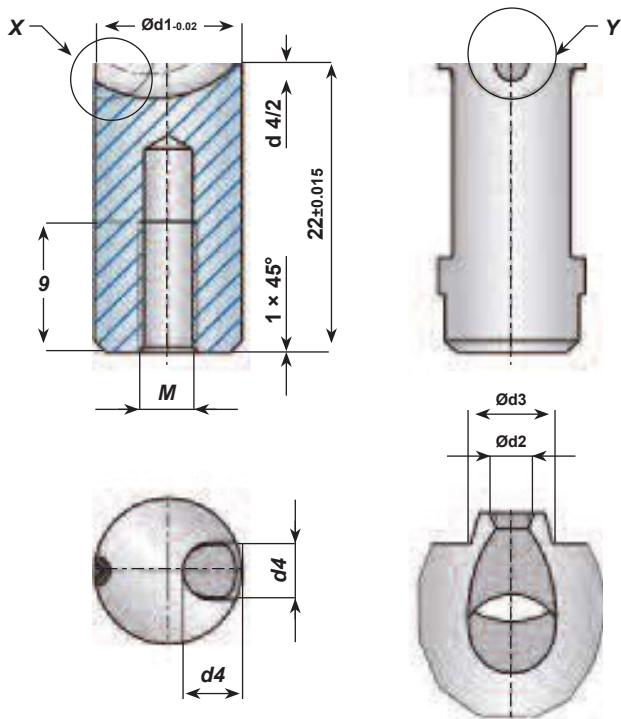

ACTUAL SIZE      EXTERNAL VIEW      CUTAWAY VIEW

- > Manufactured in a solid one-piece unit using the Metal Injection Molding (MIM) process.
- > Optimal balancing of cavity filling due to the exactness of MIM.
- > Hardened to 60HRC and polished.
- > Anti-rotation locking molded into all round inserts. However in most cases the insert is adequately held by the capscrew.

Catalog Number	d1	d2	d3	d4	M	Viscosity		
						high flowability	regular flowability	low flowability
GTR-10-08	10	0,8	2,1	4	4	8	7	5
GTR-10-10	10	1,0	2,3	4	4	14	12	9
GTR-10-12	10	1,2	2,5	4	4	20	16	10
GTR-10-14	10	1,4	2,7	4	4	30	23	15
GTR-10-16	10	1,6	2,9	4	4	40	30	20
						Weight in grams		

## Technical Information:

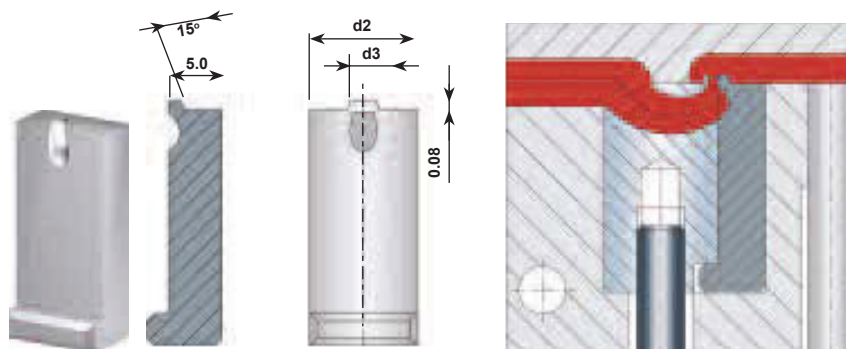

### Dead-End Recess Auxiliary Insert for GTE Series

A dead-end recess breaking the force of the melt flow can be machined either into an auxiliary insert or directly into the cavity. The auxiliary insert should be made from a highly wear-resistant steel with a hardness of 60HRC. The dimensions b2 and d3 depend on the size of the cashew gate insert selected. For recess geometries in various CAD formats please refer to the Exaflow website.

## Anti-Rotation Locking Dimensions

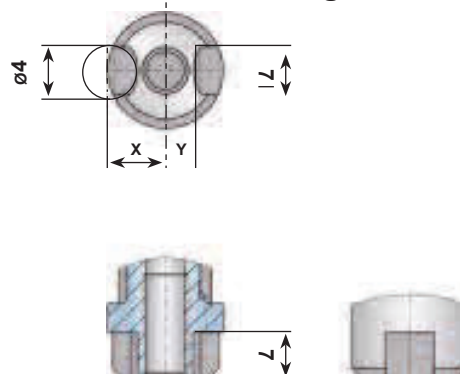

Catalog Series	Parallel Pin distance 'X'	Key distance 'Y'
GTR-10	4,5 mm	3,0 mm

CAD files available at:  
www.extraflow.com



# CASHEW GATE INSERTS

KONTOURFLOW® GTK

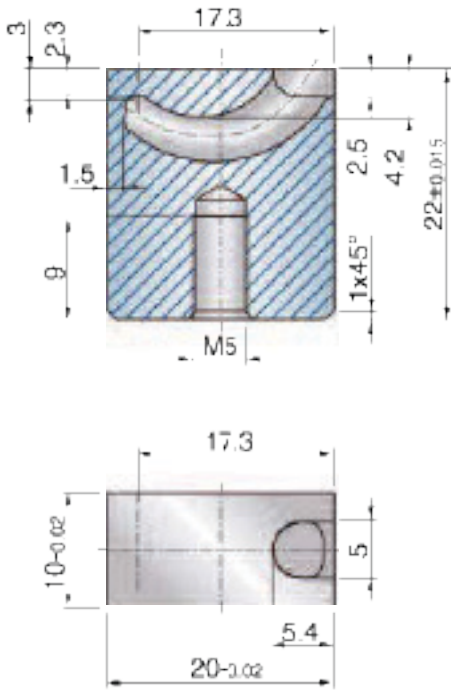

- › For tunnel gating of small to medium sized moldings contoured in the gate area
- › maximum gate diameter (pointed tunnel) up to 1,7 mm.
- › contourable up to 3 mm depth.
- › usable for all thermoplastics including fillers up to 50% glass fibre.

## Standard Design

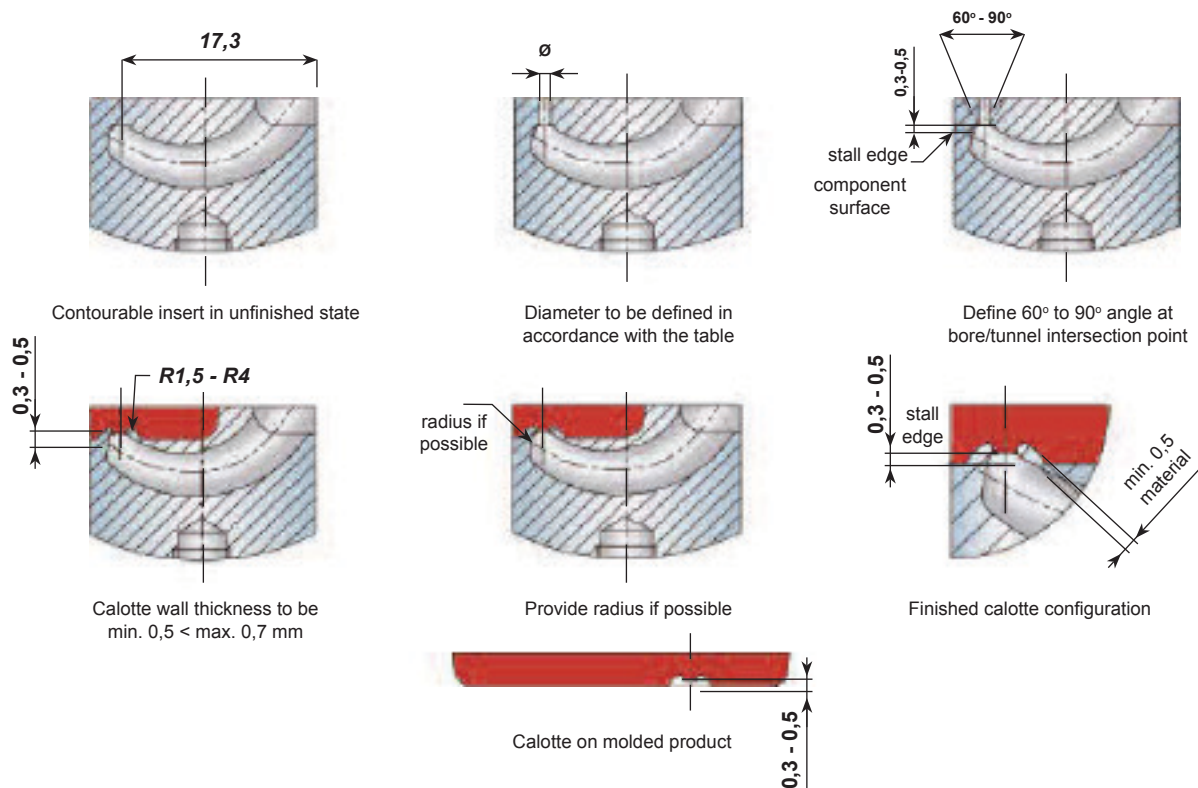

CAD files available at:

## INCLINED SURFACE

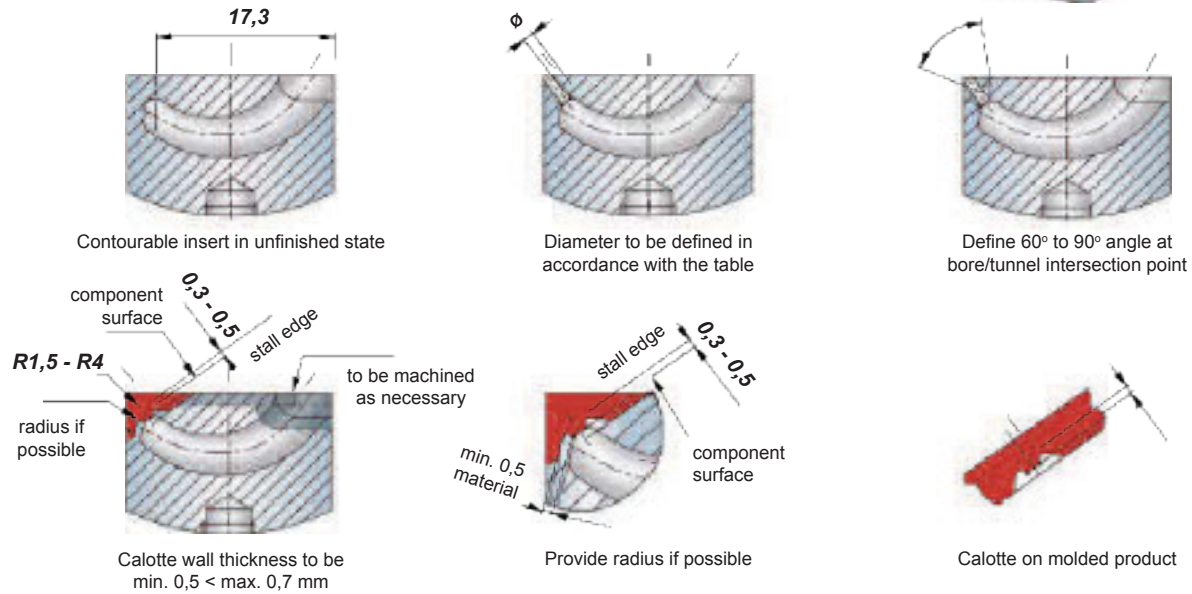

## CURVED SURFACE

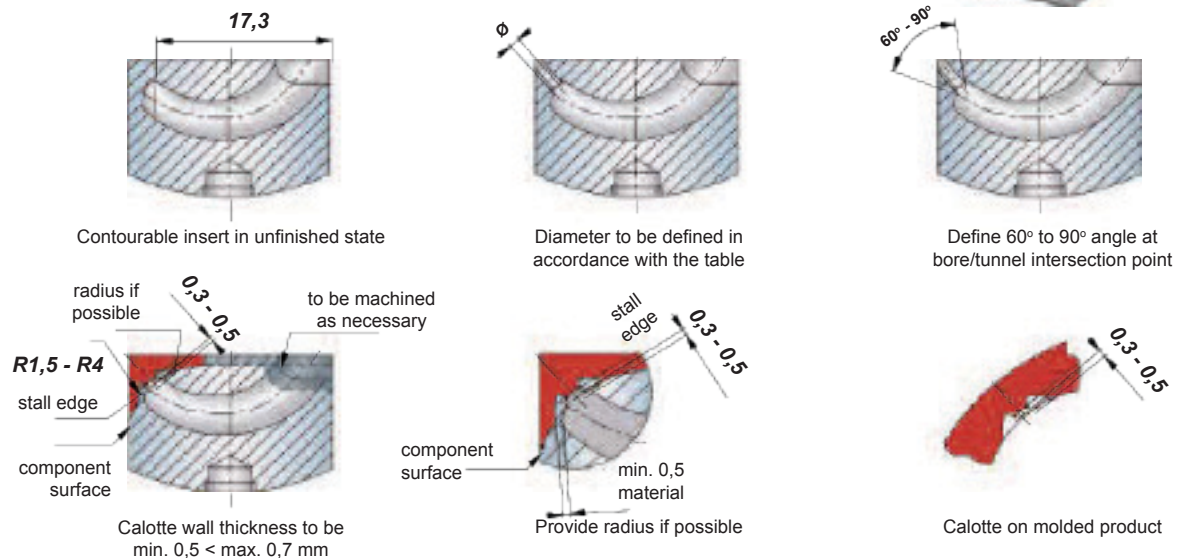

# CASHEW GATE INSERTS

MAXIFLOW — GXK

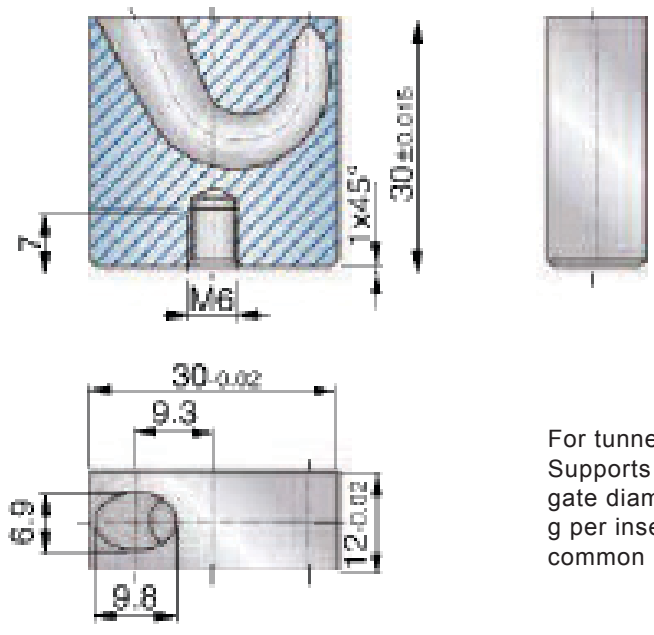

For tunnel gating of medium-to-large components. Supports contouring to a depth of 11,5 mm. Suitable for gate diameters up to 3,5 mm and shot weights up to 1,200 g per insert. The Maxiflow range can be used to process all common plastics, including reinforced types.

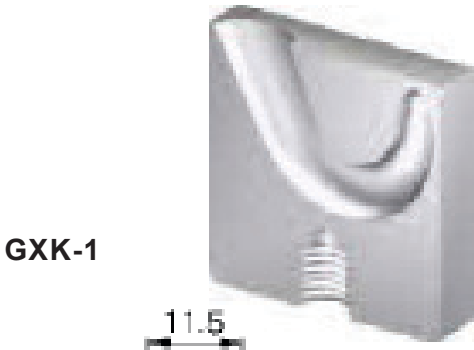

GXK-1



GXK-2



GXK-3

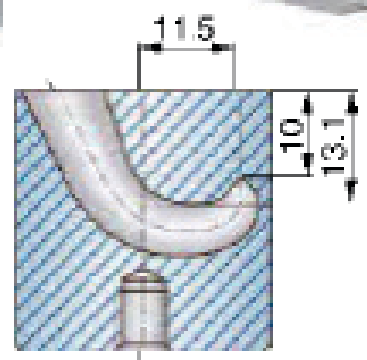
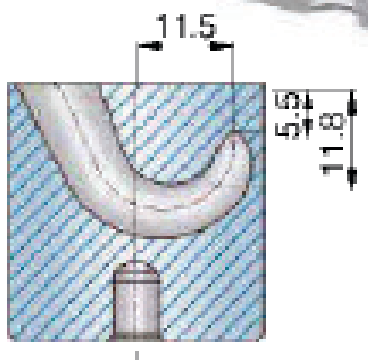
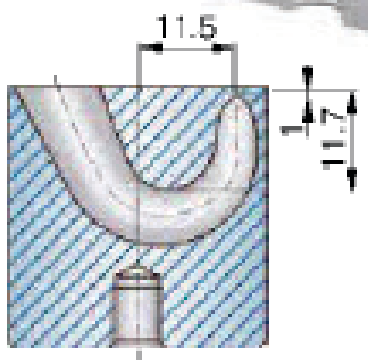

CAD files available at:  
[www.extraflow.com](http://www.extraflow.com)



# CASHEW GATE INSERTS

MAXIFLOW — GXK

## Example GXK-1

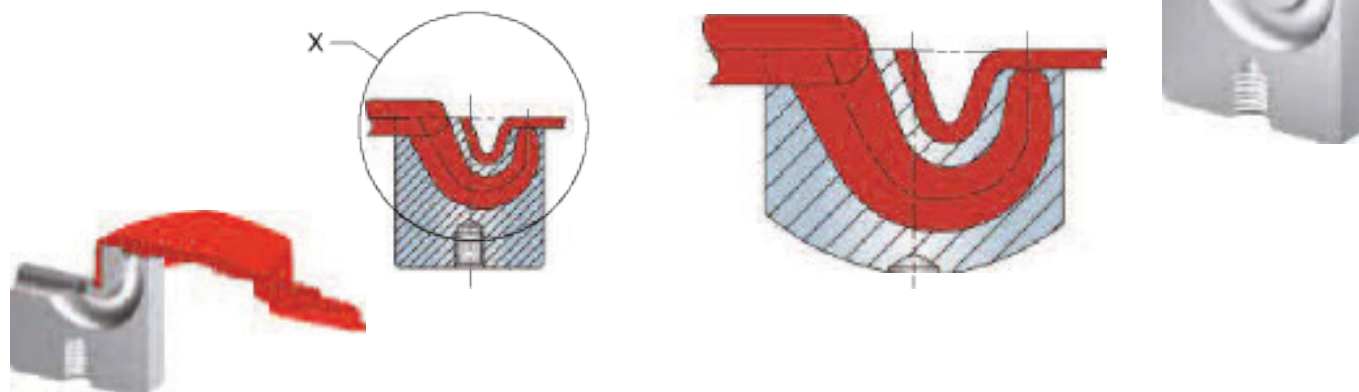

## Example GXK-2

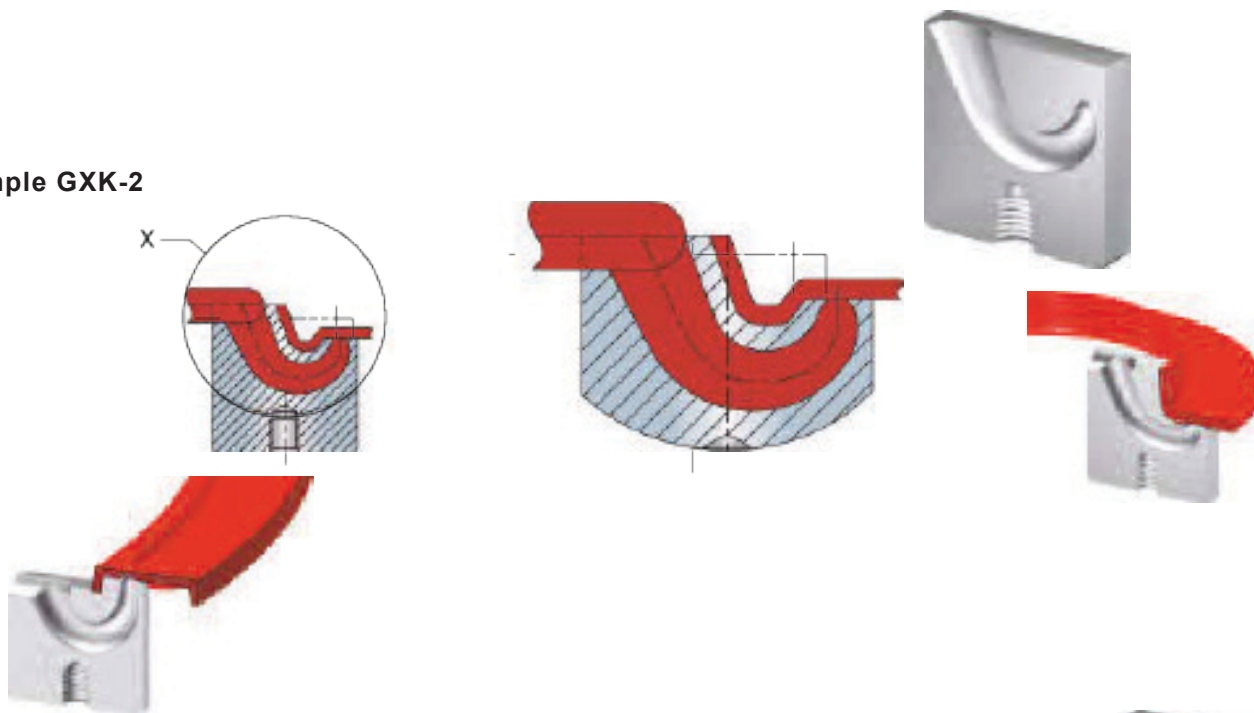

## Example GXK-3

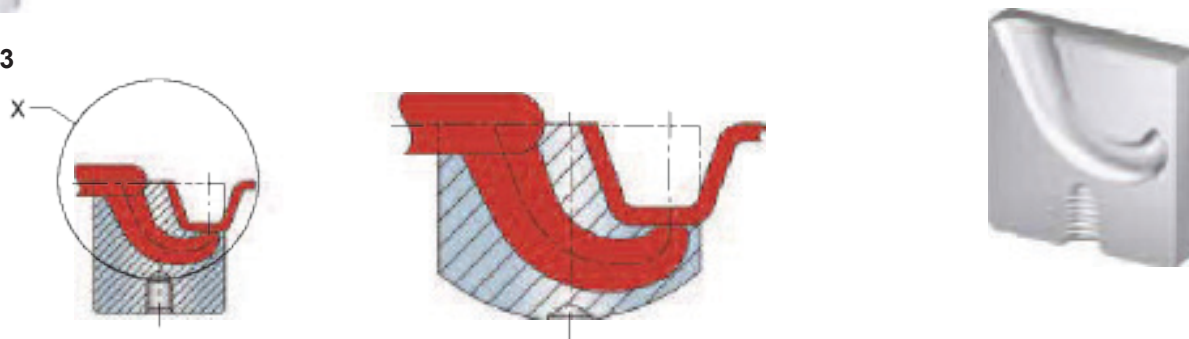

### Maxiflow benefits:

- > gating point may be located up to 10mm above or below the parting line
- > permits gating immediately behind projecting ribs
- > gate may be remote from molding wall

CAD files available at:  
[www.extraflow.com](http://www.extraflow.com)



# CASHEW GATE INSTALLATION DATA

Plastic Group	GTM	GTR/ GTE	GTK
HD-PE, LD-PE, PET, PP, PA, PC, PVC. (L)	>15	>20	>25
Runner Design	round	round	round
Ejector Depth (AT)	>11	>16	>20
ABS, M ABS, ASA, PS, PC/ABS, POM, PBT. (L)	>20	>25	>30
Runner Design	round	round	round
Ejector Depth (AT)	>14	>20	>24
Elastomers TPE, TPU, TPP, TPA. (L)	>15	>15	>20
Runner Design	arbitrary	arbitrary	arbitrary
Ejector Depth (AT)	>11	>11	>16
Brittle Plastics (L)	>25	>30	>40
Runner Design	half round	half round	half round
Ejector Depth (AT)	>18	>24	>32

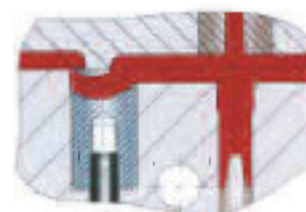
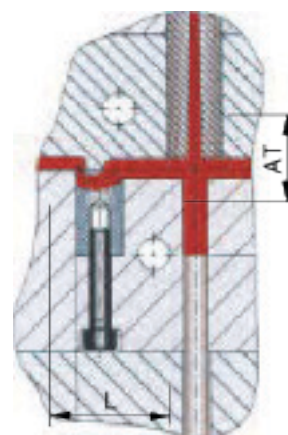



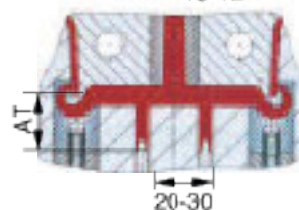
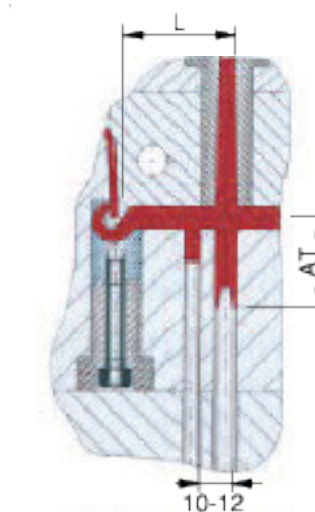









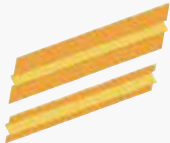

Plastic Group	GRF	GXK
HD-PE, LD-PE, PET, PP, PA, PC, PVC. (L)	>30	>35
Runner Design	round	round
Ejector Depth (AT)	>30	>35
ABS, M ABS, ASA, PS, PC/ABS, POM, PBT. (L)	>30	>40
Runner Design	round	round
Ejector Depth (AT)	>30	>40
Elastomers TPE, TPU, TPP, TPA. (L)	>20	>30
Runner Design	arbitrary	arbitrary
Ejector Depth (AT)	>20	>30
Brittle Plastics (L)	on request	on request
Runner Design	half round	half round
Ejector Depth (AT)	on request	on request



► Recommended distances 'L' from the injection point to the sprue ejector for various material groups. The distance 'AT' is the correlated ejector depth.



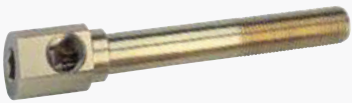







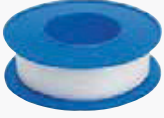



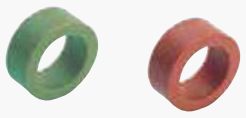

CAD files available at:  
[www.extraflow.com](http://www.extraflow.com)

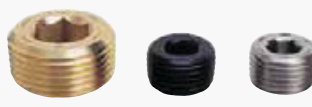

<p style="text-align: right;"><b>HC1</b></p> <p><b>Brass Baffles – Straight</b></p> 	<p style="text-align: right;"><b>HC1</b></p> <p><b>Brass Baffles – Turbo</b></p> 	<p style="text-align: right;"><b>HC1</b></p> <p><b>Blade Material</b></p> 
<p style="text-align: right;"><b>HC2</b></p> <p><b>E-Series Brass Baffles</b></p> 	<p style="text-align: right;"><b>HC3</b></p> <p><b>Standard Cascades</b></p> 	<p style="text-align: right;"><b>HC4</b></p> <p><b>High Flow Cascades</b></p> 
<p style="text-align: right;"><b>HC4</b></p> <p><b>Compact Cascades</b></p> 	<p style="text-align: right;"><b>HC5</b></p> <p><b>High Flow Tubes</b></p> 	<p style="text-align: right;"><b>HC5</b></p> <p><b>Standard Tubes, Stainless Tubes</b></p> 
<p style="text-align: right;"><b>HC5</b></p> <p><b>Piston Tubes</b></p> 	<p style="text-align: right;"><b>HC6</b></p> <p><b>Quick-Coupler Cascades</b></p> 	<p style="text-align: right;"><b>HC7</b></p> <p><b>HexKey Cascades</b></p> 
<p style="text-align: right;"><b>HC8</b></p> <p><b>Brass Extension Elbows</b></p> 	<p style="text-align: right;"><b>HC8</b></p> <p><b>Hex Elbows</b></p> 	<p style="text-align: right;"><b>HC8</b></p> <p><b>Male Hex Elbows</b></p> 
<p style="text-align: right;"><b>HC9</b></p> <p><b>HexKey Extension Elbows</b></p> 	<p style="text-align: right;"><b>HC9</b></p> <p><b>HexKey Elbows</b></p> 	<p style="text-align: right;"><b>HC10</b></p> <p><b>HexKey Extension Pipes</b></p> 

# INDEX

<p><b>HC10</b> HexKey Street Elbows</p> 	<p><b>HC11</b> Adjustable Hex Nipples</p> 	<p><b>HC11</b> Brass Pipe Nipples</p> 
<p><b>HC11</b> Galvanized Pipe Nipples</p> 	<p><b>HC12</b> Push-Lok Hose Barbs</p> 	<p><b>HC12</b> Safety Clips</p> 
<p><b>HC13</b> Reducing Bushings</p> 	<p><b>HC13</b> Male Reducers</p> 	<p><b>HC13</b> 45° Street El's</p> 
<p><b>HC13</b> 90° Street El's</p> 	<p><b>HC13</b> 90° Elbows</p> 	<p><b>HC13</b> Tees</p> 
<p><b>HC13</b> Hex Nipples</p> 	<p><b>HC13</b> Male Hose Barbs</p> 	<p><b>HC13</b> Female Hose Barbs</p> 
<p><b>HC13</b> Hose Splicers</p> 	<p><b>HC13</b> Hex Couplings</p> 	<p><b>HC13</b> Hose Clamps</p> 

<p><b>HC13</b> Teflon Tape</p> 	<p><b>HC14</b> Sockets</p> 	<p><b>HC15</b> Locking</p> 
<p><b>HC16</b> Socket Body</p> 	<p><b>HC16</b> Seals</p> 	<p><b>HC16</b> Male Connector Plugs (Brass)</p> 
<p><b>HC16</b> Female Connector Plugs (Plated Steel)</p> 	<p><b>HC16</b> Female Connector Plugs (Brass)</p> 	<p><b>HC17 - HC18</b> Brass Extension Plugs</p> 
<p><b>HC19</b> Quick-Coupler Water Jumpers</p> 	<p><b>HC20</b> Swivel Water Jumpers</p> 	<p><b>HC21</b> Pressure Plugs</p> 
<p><b>HC21</b> Threadless Plugs</p> 	<p><b>HC21</b> O-Ring Plugs</p> 	<p><b>HC21</b> Heavy Duty Plugs / BSP Plugs / Stop Plugs</p> 
<p><b>HC22</b> Pipe Plug Diverters</p> 	<p><b>HC22</b> Combination Hose Inserts</p> 	<p><b>HC23 - HC24</b> Isobar® Heat Pipes</p> 

**HC25**  
High Temperature  
Insulator Sheets

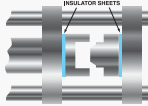

A technical diagram showing a cross-section of a high-temperature insulator assembly. It consists of multiple layers of insulator sheets held together by metal clamps. The text 'INSULATOR SHEETS' is visible at the top of the diagram.

**HC25**  
Locating Rings for  
Insulator Sheets



Two blue cylindrical locating rings are shown, designed to fit around a pipe or rod to precisely position insulator sheets during assembly.

**HC26 - HC28**  
Temperature Control Systems



A collection of temperature control equipment, including a large industrial unit on wheels, a control panel with numerous buttons and a digital display, and a smaller electronic device.

**HC29**  
360° Manifolds



A red and blue 360-degree manifold, which is a cylindrical component with multiple ports around its circumference, used for distributing fluid flow in a circular pattern.

**HC30 - HC33**  
Compound Flexible Water  
Manifold System



Two compound flexible water manifold systems are shown, one in red and one in blue. They are flexible, cylindrical manifolds with multiple ports.

**HC34**  
Specials



A variety of specialized components including a blue manifold plate with four ports, several brass fittings, and various types of probes and sensors.

# BRASS BAFFLES

## STRAIGHT

CATALOG NUMBER	P PLUG SIZE (NPT)	L OVERALL LENGTH (INCHES)	W BLADE WIDTH (-.005 (-.015))	DRILL SIZE	B BLADE THICKNESS
BA0604	1/16	4	1/4	1/4	0.057
BA0608	1/16	8	1/4	1/4	0.057
BA0612	1/16	12	1/4	1/4	0.057
BA1204	1/8	4	5/16	5/16	0.057
BA1208	1/8	8	5/16	5/16	0.057
BA1212	1/8	12	5/16	5/16	0.057
BA2505	1/4	5	7/16	7/16	0.085
BA2510	1/4	10	7/16	7/16	0.085
BA2515	1/4	15	7/16	7/16	0.085
BA3706	3/8	6	9/16	9/16	0.093
BA3712	3/8	12	9/16	9/16	0.093
BA3718	3/8	18	9/16	9/16	0.093
BA5008	1/2	8	11/16	11/16	0.093
BA5016	1/2	16	11/16	11/16	0.093
BA7512	3/4	12	15/16	15/16	0.093
BA7520	3/4	20	15/16	15/16	0.093
BA7536	3/4	36	15/16	15/16	0.093
BA9016	1"	16	1-1/8	1-1/8	0.102
BA9024	1"	24	1-1/8	1-1/8	0.102
BA9036	1"	36	1-1/8	1-1/8	0.102

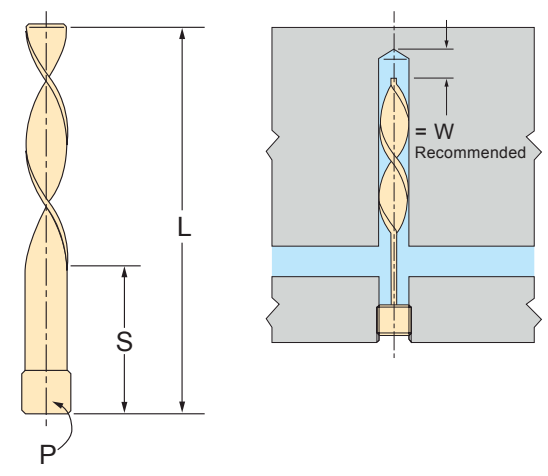
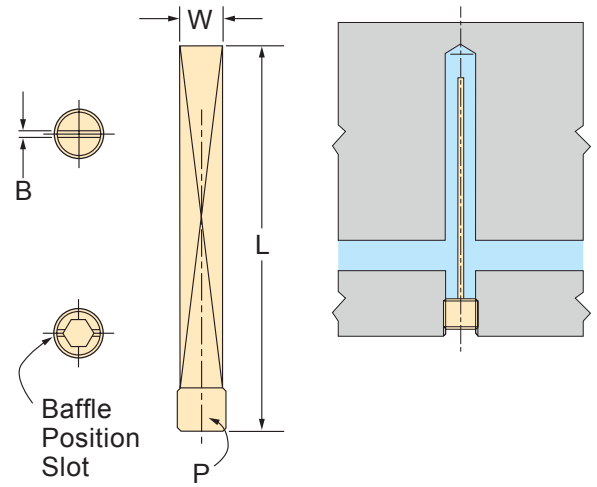

## TURBO

CATALOG NUMBER	P PLUG SIZE (NPT)	L OVERALL LENGTH (INCHES)	W BLADE WIDTH (-.005 (-.015))	DRILL SIZE	B BLADE THICKNESS	S STRAIGHT LENGTH (INCHES)
TB0604	1/16	4	1/4	1/4	0.050	2
TB0608	1/16	8	1/4	1/4	0.050	4
TB0612	1/16	12	1/4	1/4	0.050	6
TB1204	1/8	4	5/16	5/16	0.050	2
TB1208	1/8	8	5/16	5/16	0.050	4
TB1212	1/8	12	5/16	5/16	0.050	6
TB2505	1/4	5	7/16	7/16	0.080	2
TB2510	1/4	10	7/16	7/16	0.080	4
TB2515	1/4	15	7/16	7/16	0.080	6
TB3706	3/8	6	9/16	9/16	0.090	2
TB3712	3/8	12	9/16	9/16	0.090	4
TB3718	3/8	18	9/16	9/16	0.090	6
TB5008	1/2	8	11/16	11/16	0.090	3
TB5016	1/2	16	11/16	11/16	0.090	5
TB7512	3/4	12	15/16	15/16	0.090	4
TB7520	3/4	20	15/16	15/16	0.090	6
TB9016	1"	16	1-1/8	1-1/8	0.105	5
TB9024	1"	24	1-1/8	1-1/8	0.105	8



## BAFFLE PLATE MATERIAL

CATALOG NUMBER	(REF.) PLUG SIZE (NPT)	OVERALL LENGTH (INCHES)	BLADE WIDTH (-.005 (-.015))	BLADE THICKNESS
BM06-025-36	1/16	36	1/4	0.050
BM12-031-36	1/8	36	5/16	0.050
BM25-043-36	1/4	36	7/16	0.080
BM37-056-36	3/8	36	9/16	0.090
BM50-068-36	1/2	36	11/16	0.090
BM75-090-36	3/4	36	29/32	0.090
BM75-093-36	3/4	36	15/16	0.090
BM90-112-36	1"	36	1-1/8	0.105

- Flush-seal (7/8 taper) brass pipe plugs are standard.
- Steel, stainless, and 3/4 taper are available.
- Turbo baffles create turbulent cooling action and keeps blade centered in the cooling channel. Patented technology allows 300% more wrenching torque. (Not on 1" baffles.)

# E-SERIES BRASS BAFFLES

DMS "E-Series" brass baffles are an economical way to baffle longer water lines.

- > Will not twist in hole due to its configuration.
- > Will not rotate out of its located position.
- > Recommended for use in Die Cast Dies where high temperatures are used.

Simply cut to the required length and insert slightly short of final depth. These baffles will then be forced home by a pipe plug or block.

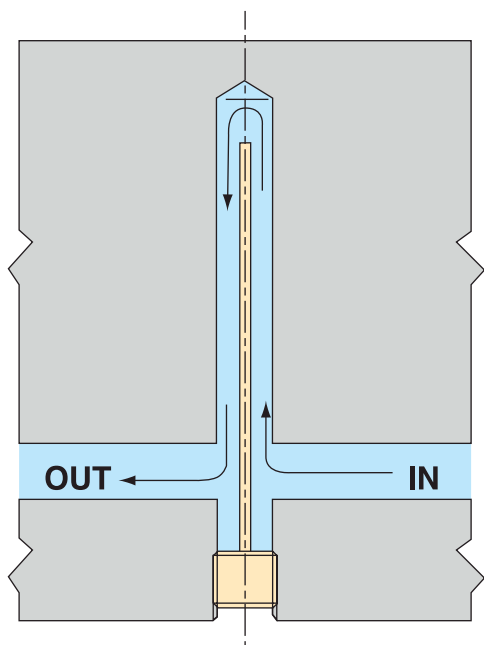
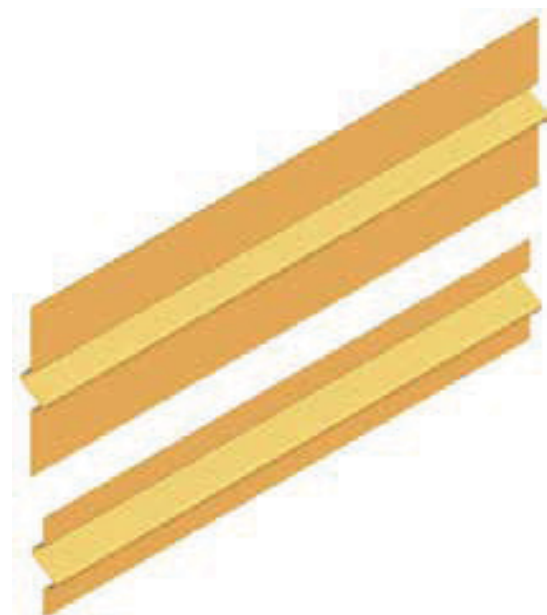
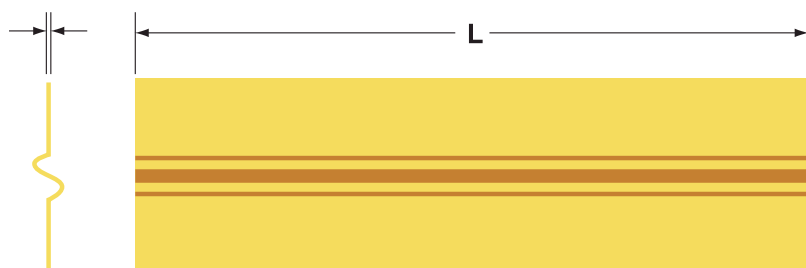

CATALOG NUMBER	A	B	PIPE THREAD	DRILL SIZE	LENGTH ± .004
EB25-48	0.437	0.446	1/4NPT	7/16	48"
EB37-48	0.562	0.576	3/8NPT	9/16	48"
EB50-48	0.688	0.703	1/2NPT	11/16	48"
EB75-48	0.906	0.926	3/4NPT	15/16	48"
EB100-48	1.125	1.150	1"NPT	1-1/8	48"

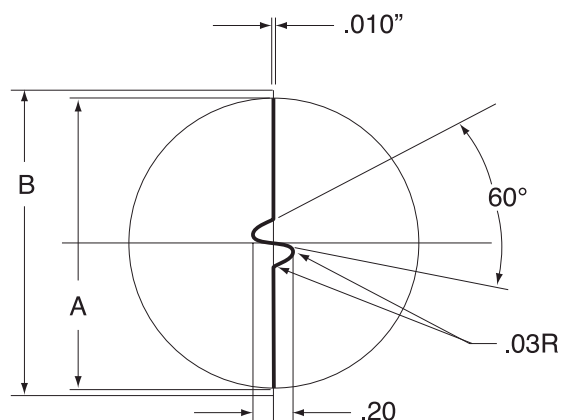

# STANDARD CASCADES



## ASSEMBLIES

- Assemblies include brass head, 12" brass tube, 2" long galvanized pipe nipple, and brass pipe plug.
- Order extra length brass tubes below.
- Cascade assemblies are available in special pipe tap and tube combinations.

NUMBER	NIPPLE (NPT)	SIZE (NPT)	TUBE O.D.	TUBE INCLUDED	HEX SIZE	E	C	A	L
16N	1/8	1/16	3/16	187T-12	3/4	7/32	1/2	9/32	15/16
186N	1/8	1/8	3/16	187T-12	7/8	21/64	11/16	9/32	1-11/32
181N	1/8	1/8	3/16	187T-12	7/8	21/64	1"	9/32	1-21/32
146N	1/4	1/8	1/4	250T-12	1"	21/64	11/16	7/32	1-11/32
146N-4	1/4	1/4	1/4	250T-12	1"	21/64	11/16	7/32	1-11/32
141N	1/4	1/8	1/4	250T-12	1"	21/64	1"	7/16	1-21/32
141N-4	1/4	1/4	1/4	250T-12	1"	21/64	1"	7/16	1-21/32
381N	3/8	1/8	5/16	312T-12	1"	11/32	1"	13/32	1-11/16
381N-4	3/8	1/4	5/16	312T-12	1"	11/32	1"	13/32	1-11/16
121N-4	1/2	1/4	7/16	437T-12	1-1/4	13/32	1"	9/16	1-13/16
341N-4	3/4	3/8	5/8	625T-12	1-1/2	1/2	1-1/4	3/4	2-1/4

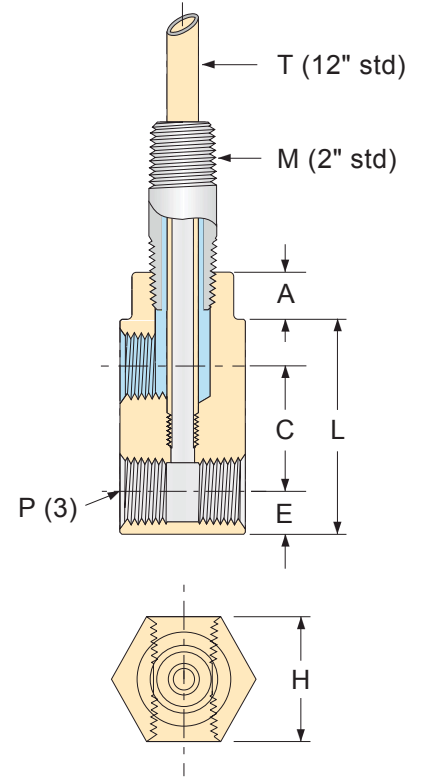

CATALOG NUMBER	TUBE THREAD SIZE	BRASS TUBE NUMBER
16H	10-32	187T-
186H	10-32	187T-
181H	10-32	187T-
146H	1/4-28	250T-
146H-4	1/4-28	250T-
141H	1/4-28	250T-
141H-4	1/4-28	250T-
381H	5/16-24	312T-
381H-4	5/16-24	312T-
121H-4	7/16-20	437T-
341H-4	5/8-18	625T-

## HEADS

- For use with standard brass tubes.
- All dimensions are same as above assembly chart for corresponding catalog number.
- Supplied with brass pipe plug.
- Special pipe tap sizes, tube thread sizes and hole locations are available.
- Use brass tubes on page HC5.



CATALOG NUMBER	TUBE THREAD SIZE	HIGH FLOW TUBE NUMBER
16H-HFT	1/4-28	HF187T-
186H-HFT	1/4-28	HF187T-
181H-HFT	1/4-28	HF187T-
146H-HFT	5/16-24	HF250T-
146H-4-HFT	5/16-24	HF250T-
141H-HFT	5/16-24	HF250T-
141H-4-HFT	5/16-24	HF250T-
381H-HFT	3/8-24	HF312T-
381H-4-HFT	3/8-24	HF312T-
121H-4-HFT	1/2-20	HF437T-

## HIGH FLOW HEADS

- For use with high flow stainless tubes.
- All dimensions are same as above assembly chart except for tube thread size.
- Supplied with brass pipe plug.
- Special pipe tap sizes, tube thread sizes and hole locations are available.
- Use high flow stainless tubes on page HC5.



# HIGH FLOW CASCADES

Increased inlet areas produce higher flow rates.



## ASSEMBLIES

CATALOG NUMBER	M PIPE NIPPLE (NPT)	P PIPE TAP SIZE (NPT)	T HIGH FLOW TUBE O.D.	T HIGH FLOW TUBE INCLUDED	H HEX SIZE	OFFSET	E	C	L	% ACTUAL FLOW INCREASE
HF16N	1/16	1/16	1/8	HF125T-12	5/8	3/32	1/4	1/2	1-1/4	-
HF186N	1/8	1/8	3/16	HF187T-12	3/4	3/32	5/16	11/16	1-5/8	64%
HF181N	1/8	1/8	3/16	HF187T-12	3/4	3/32	5/16	1"	1-15/16	64%
HF146N-4	1/4	1/4	1/4	HF250T-12	1"	5/32	11/32	11/16	1-7/8	48%
HF141N-4	1/4	1/4	1/4	HF250T-12	1"	5/32	11/32	1"	2-3/16	48%
HF381N-4	3/8	1/4	3/8	HF375T-12	1-1/8	1/8	3/2	1"	2-1/4	38%

## HEADS



CATALOG NUMBER	HIGH FLOW TUBE THREAD SIZE	USE HIGH FLOW TUBE NUMBER
HF16H	10-32	HF125T-
HF186H	1/4-28	HF187T-
HF181H	1/4-28	HF187T-
HF146H-4	5/16-24	HF250T-
HF141H-4	5/16-24	HF250T-
HF381H-4	7/16-20	HF375T-

- Up to 64% higher flow rates than standard cascades.
- Offset design provides more sealing threads without pipe interference.
- Assemblies include brass head, 12" high flow stainless tube, and 2" long galvanized pipe nipple.

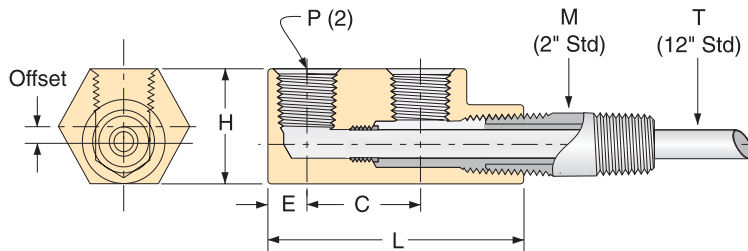

- All dimensions are same as above assembly chart.
- Special pipe tap sizes and tube combinations are available.
- Use high flow stainless tubes on page HC5.

# COMPACT CASCADES

## ASSEMBLIES

CATALOG NUMBER	M PIPE NIPPLE (NPT)	P IN/OUT PIPE (NPT)	T HIGH FLOW TUBE O.D.	HIGH FLOW TUBE INCLUDED	H HEX SIZE	A	B	C	D	E	F
ET1816	1/8	1/16	3/16	HF187T-12	15/16	7/32	7/16	1/2	1"	5/8	0.330
ET1418	1/4	1/8	1/4	HF250T-12	1-1/4	5/16	5/8	11/16	1-1/4	3/4	0.410
ET1414	1/4	1/4	1/4	HF250T-12	1-1/2	3/8	3/4	3/4	1-1/2	7/8	0.540
ET3814	3/8	1/4	5/16	HF312T-12	1-1/2	3/8	3/4	3/4	1-1/2	1"	0.540

- Assemblies include brass head, 12" high flow stainless tube, and 2" long galvanized pipe nipple.
- In/Out connections are positioned sideways for mounting in tight spaces or thin mold plates.

## HEADS

CATALOG NUMBER	M PIPE NIPPLE (NPT)	P IN/OUT PIPE (NPT)	HIGH FLOW TUBE THREAD SIZE	USE HIGH FLOW TUBE NUMBER
ET1816H	1/8	1/16	1/4-28	HF187T-
ET1418H	1/4	1/8	5/16-24	HF250T-
ET1414H	1/4	1/4	5/16-24	HF250T-
ET3814H	3/8	1/4	3/8-24	HF312T-

- All dimensions are same as above assembly chart.
- Use high flow stainless tubes on page HC5.

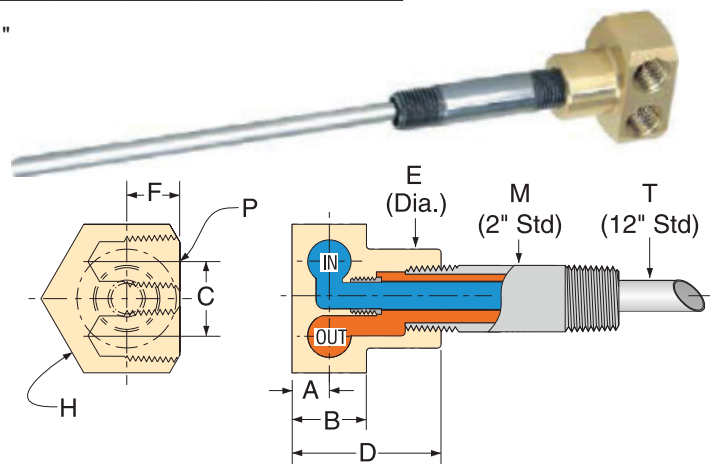

Compact Cascades provide maximum cooling rates with improved design and High Flow Tubes.



# HIGH FLOW TUBES

INCREASE FLOW UP TO 300%



TUBE O.D.	TUBE I.D.	THREAD SIZE	THREAD LENGTH	CATALOG NUMBER			
				12"	18"	24"	36"
0.090	0.076	5-44	1/8	HF093T-12	HF093T-18	HF093T-24	HF093T-36
0.090	0.076	10-32	3/16	JHF093T-12	JHF093T-18	JHF093T-24	JHF093T-36
0.125	0.109	10-32	3/16	HF125T-12	HF125T-18	HF125T-24	HF125T-36
0.125	0.109	1/4-28	1/4	JHF125T-12	JHF125T-18	JHF125T-24	JHF125T-36
0.187	0.167	1/4-28	1/4	HF187T-12	HF187T-18	HF187T-24	HF187T-36
0.187	0.167	5/16-24	5/16	JHF187T-12	JHF187T-18	JHF187T-24	JHF187T-36
0.250	0.230	5/16-24	5/16	HF250T-12	HF250T-18	HF250T-24	HF250T-36
0.250	0.230	3/8-24	3/8	JHF250T-12	JHF250T-18	JHF250T-24	JHF250T-36
0.312	0.288	3/8-24	3/8	HF312T-12	HF312T-18	HF312T-24	HF312T-36
0.312	0.288	7/16-20	7/16	JHF312T-12	JHF312T-18	JHF312T-24	JHF312T-36
0.365	0.340	7/16-20	7/16	HF375T-12	HF375T-18	HF375T-24	HF375T-36
0.365	0.340	1/2-20	1/2	JHF375T-12	JHF375T-18	JHF375T-24	JHF375T-36
0.427	0.397	1/2-20	1/2	HF437T-12	HF437T-18	HF437T-24	HF437T-36

- > All stainless construction for high strength and durability.
- > Cut to exact lengths at no charge.
- > We stock over 150 sizes of thin wall stainless tube.
- > We build stepped tube assemblies and custom threaded tubes to your print.

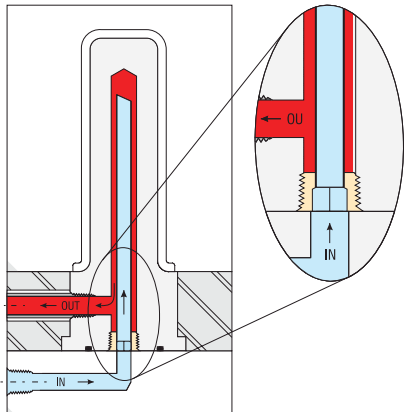

# STANDARD TUBES



TUBE O.D.	TUBE I.D.	THREAD SIZE	THREAD LENGTH	CATALOG NUMBER			
				12"	18"	24"	36"
0.125	0.062	5 -44	3/16	125T-12	125T-18	125T-24	125T-36
0.187	0.123	10 -32	3/16	187T-12	187T-18	187T-24	187T-36
0.250	0.170	1/4 -28	1/4	250T-12	250T-18	250T-24	250T-36
0.312	0.210	5/16 -24	5/16	312T-12	312T-18	312T-24	312T-36
0.375	0.273	3/8 -24	3/8	375T-12	375T-18	375T-24	375T-36
0.437	0.307	7/16 -20	7/16	437T-12	437T-18	437T-24	437T-36
0.625	0.495	5/8 -18	5/8	625T-12	625T-18	625T-24	625T-36

- > Tubes 18" and longer have both ends threaded.
- > Half-hard temper for reliable performance.
- > Also available in stainless steel.
- > Bulk tube available.

# PISTON TUBES

PIPE SIZE (NPT)	TUBE O.D.	TUBE I.D.	CATALOG NUMBER			
			12"	24"	36"	48"
1/16	0.125	0.109	PT16-12	PT16-24	PT16-36	PT16-48
1/8	0.187	0.167	PT18-12	PT18-24	PT18-36	PT18-48
1/4	0.250	0.230	PT14-12	PT14-24	PT14-36	PT14-48
3/8	0.365	0.345	PT38-12	PT38-24	PT38-36	PT38-48
1/2	0.365	0.340	PT12-12	PT12-24	PT12-36	PT12-48
3/4	0.427	0.397	PT34-12	PT34-24	PT34-36	PT34-48

- > Precision brazed assembly provides high strength and reliable performance.
- > Flow thru pipe plug is available in custom sizes and materials.

Coolant flows through hex socket and high flow stainless tube.

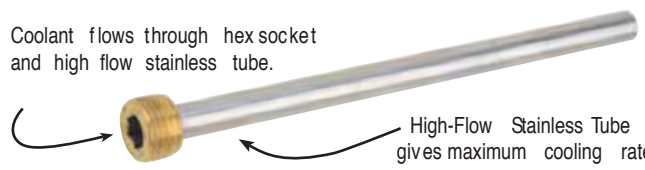

# STAINLESS TUBES

TUBE O.D.	TUBE I.D.	THREAD SIZE	CATALOG NUMBER
0.093	0.077	NO THREADS	093TS-18
0.125	0.062	5 -44	125TS-18
0.187	0.123	10 -32	187TS-18
0.250	0.170	1/4 -28	250TS-18
0.312	0.210	5/16 -24	312TS-18

- > Stainless tubes are 18" overall.
- > Standards are threaded on both ends.



# QUICK-COUPLER CASCADES

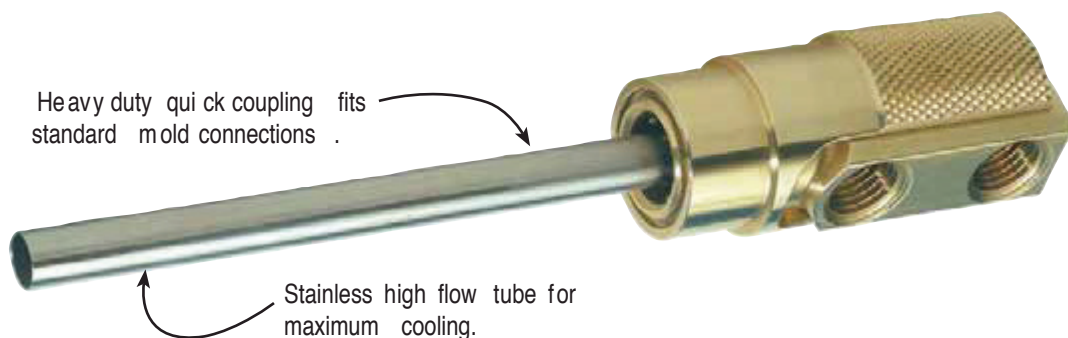

## ASSEMBLIES

CATALOG NUMBER	P PIPE TAP SIZE (NPT)	T HIGH FLOW TUBE THREAD	HIGH FLOW TUBE INCLUDED	H HEX KEY SIZE	L	C	A	D ACTUAL SIZE O.D.
SC186N	1/8	1/4-28	HF187T-12	13/16	1.937	11/16	31/32	7/8
SC181N	1/8	1/4-28	HT187T-12	13/16	2.250	1"	31/32	7/8
SC146N-4	1/4	5/16-24	HT250T-12	1"	2.187	11/16	1-5/32	1-1/8
SC141N-4	1/4	5/16-24	HT250T-12	1"	2.500	1"	1-5/32	1-1/8
SC121N-4	1/4	1/2-20	HT437T-12	1-1/4	3.125	1-1/4	1-1/4	1-3/8
SC121N-6	3/8	1/2-20	HT437T-12	1-1/4	3.125	1-1/4	1-1/4	1-3/8

- > Can be installed and removed without disconnecting coolant lines.
- > Viton Seals standard.
- > High flow design provides maximum cooling rates.
- > 12" high flow stainless tube included.

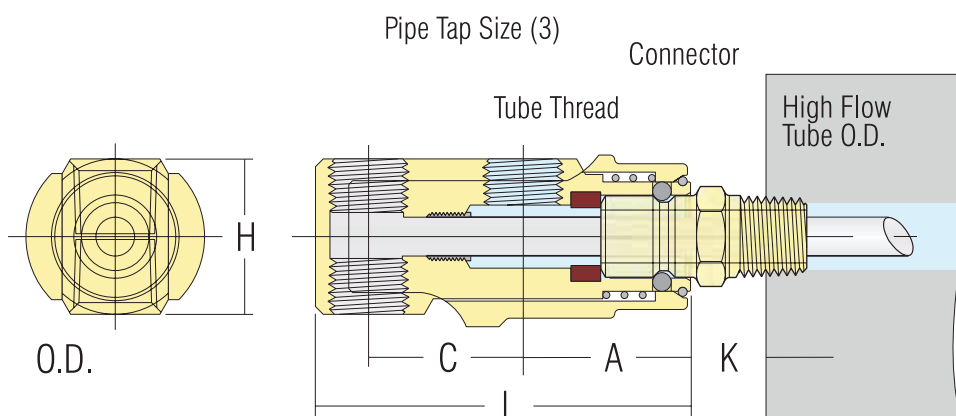

## HEADS

CATALOG NUMBER	HIGH FLOW TUBE THREAD SIZE	USE HIGH FLOW TUBE NUMBER
SC186H	1/4-28	HF187T-
SC181H	1/4-28	HF187T-
SC146H-4	5/16-24	HF250T-
SC141H-4	5/16-24	HF250T-
SC121H-4	1/2-20	HF437T-
SC121H-6	1/2-20	HF437T-



- > Aids in quick and efficient assembly and disassembly of cooling circuit.
- > Heavy duty all brass and stainless steel construction.
- > Dimensions are same as above assembly chart for corresponding catalog number.
- > Use high flow tubes on page HC5.



# HEXKEY CASCADES

HexKey Cascades are round, and install with an Allen wrench. They may be installed with minimal clearance or very close together where space is limited.



## ASSEMBLIES

CATALOG NUMBER	M PIPE NIPPLE (NPT)	P PIPE TAP SIZE (NPT)	T HIGH FLOW TUBE O.D.	HIGH FLOW TUBE INCLUDED	H HEX KEY SIZE	L	C	A	NOMINAL CLEARANCE DRILL	D ACTUAL O.D.
E16N	1/16	1/16	1/8	HF125T-12	5/16	1.625	9/16	1/2	5/8	0.610
E16N-2	1/8	1/16	3/16	HT187T-12	3/8	1.687	9/16	9/16	3/4	0.735
E186N	1/8	1/8	3/16	HT187T-12	3/8	1.875	11/16	9/16	7/8	0.860
E181N	1/8	1/8	3/16	HT187T-12	3/8	2.187	1"	9/16	7/8	0.860
E146N	1/4	1/8	1/4	HT250T-12	1/2	2.187	11/16	13/16	1"	0.985
E146N-4	1/4	1/4	1/4	HT250T-12	1/2	2.312	11/16	7/8	1"	0.985
E141N	1/4	1/8	1/4	HT250T-12	1/2	2.500	1"	13/16	1"	0.985
E141N-4	1/4	1/4	1/4	HT250T-12	1/2	2.625	1"	7/8	1"	0.985
E381N-4	3/8	1/4	5/16	HT312T-12	1/2	2.625	1"	7/8	1"	0.985
E121N-4	1/2	1/4	3/8	HT375T-12	1/2	2.812	1"	1"	1-1/4	1.235

## HEADS

CATALOG NUMBER	HIGH FLOW TUBE THREAD SIZE	USE HIGH FLOW TUBE NUMBER
E16H	10-32	HF125T-
E16H-2	1/4-28	HF187T
E186H	1/4-28	HF187T-
E181H	1/4-28	HF187T-
E146H	5/16-24	HF250T-
E146H-4	5/16-24	HF250T-
E141H	5/16-24	HF250T-
E141H-4	5/16-24	HF250T-
E381H-4	3/8-24	HF312T-
E121H-4	7/16-20	HF375T-

- › Assemblies include brass head, 12" high flow stainless tube, and 2" long galvanized pipe nipple.
- › Easy to install and remove.

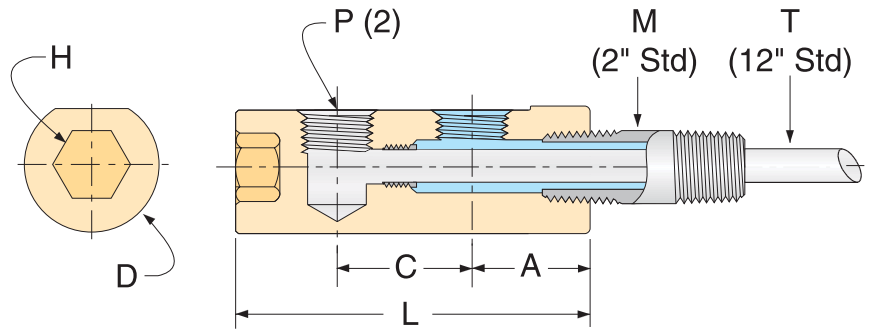

- › All dimensions are same as above assembly chart.
- › HexKey Cascade heads use High Flow stainless tubes on page HC5.

# BRASS EXTENSION ELBOWS

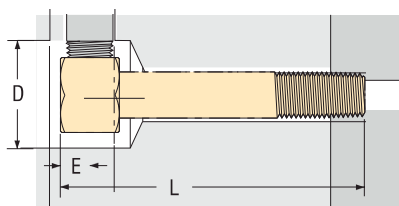

- ▶ Positive socket wrench installation.
- ▶ One piece construction ensures positive alignment, and complete removal.
- ▶ Easy length adjustment (see Brass Extension Plugs).
- ▶ Custom elbows are available in exact lengths and a wide variety of thread combinations. (Including BSP)

ELBOW NUMBER	P TAP SIZE FEMALE (NPT)	M PIPE SIZE MALE (NPT)	HEX SIZE	D WRENCH CLEARANCE DIAMETER	E	2-1/2	4"	OVERALL LENGTH			"L" 10"	11-1/2	13"
								5-1/2	7"	8-1/2			
18B	1/8	1/8	3/4	1-1/4	9/32	X025	X040	X055	X070	X085	X100	X115	X130
1814B	1/8	1/4	3/4	1-1/4	9/32	X025	X040	X055	X070	X085	X100	X115	X130
14B	1/4	1/4	7/8	1-3/8	11/32	X025	X040	X055	X070	X085	X100	X115	X130
1438B	1/4	3/8	7/8	1-3/8	11/32	X025	X040	X055	X070	X085	X100	X115	X130
38B	3/8	3/8	1"	1-1/2	1/2	X025	X040	X055	X070	X085	X100	X115	X130
50B	1/2	1/2	1-1/4	1-3/4	5/8	X025	X040	X055	X070	X085	X100	X115	X130

# HEX ELBOWS

- ▶ Available in brass or zinc plated steel.
- ▶ Angular flow path allows connecting fittings to be torqued tight without choking off flow.
- ▶ Easy socket wrench installation and removal.
- ▶ Requires much smaller clearance diameter than standard pipe elbows.

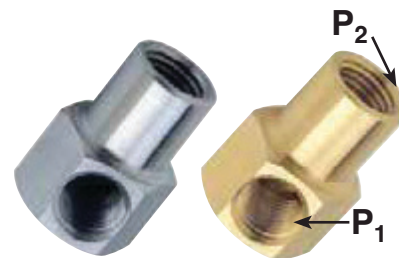

ELBOW NUMBER	P1 TAP SIZE FEMALE (NPT)	P2 TAP SIZE FEMALE (NPT)	L	E	D WRENCH CLEARANCE DIAMETER	HEX SIZE	CATALOG NUMBER	
							STEEL	BRASS
16S	1/16	1/16	13/16	7/32	1"	9/16	16S-S	16S-B
18S	1/8	1/8	1"	9/32	1-1/4	3/4	18S-S	18S-B
1814S	1/8	1/4	1-1/4	9/32	1-1/4	3/4	1814S-S	1814S-B
14S	1/4	1/4	1-3/8	11/32	1-3/8	7/8	14S-S	14S-B
1438S	1/4	3/8	1-3/8	11/32	1-3/8	7/8	1438S-S	1438S-B
38S	3/8	3/8	1-5/8	1/2	1-1/2	1"	38S-S	38S-B
50S	1/2	1/2	1-7/8	9/16	1-7/8	1-1/4	50S-S	50S-B
75S	3/4	3/4	2-1/4	5/8	2-1/4	1-1/2	75S-S	75S-B



# MALE HEX ELBOWS

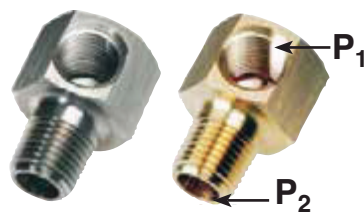
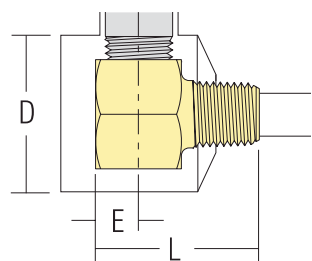

- ▶ Available in brass or plated steel.
- ▶ Easy socket wrench installation and removal.
- ▶ Full flow path allows connecting fittings to be torqued tight without choking off flow.
- ▶ Requires minimum clearance diameter.

ELBOW NUMBER	P2 TAP SIZE MALE (NPT)	L	E	D WRENCH CLEARANCE DIAMETER	HEX SIZE	CATALOG NUMBER	
						STEEL	BRASS
16MS	1/16	13/16	7/32	1"	9/16	16MS-S	16MS-B
18MS	1/8	1"	9/32	1-1/4	3/4	18MS-S	18MS-B
1814MS	1/4	1-1/4	9/32	1-1/4	3/4	1814MS-S	1814MS-B
14MS	1/4	1-3/8	11/32	1-3/8	7/8	14MS-S	14MS-B
1438MS	3/8	1-3/8	11/32	1-3/8	7/8	1438MS-S	1438MS-B
38MS	3/8	1-5/8	1/2	1-1/2	1"	38MS-S	38MS-B
50MS	1/2	1-7/8	9/16	1-7/8	1-1/4	50MS-S	50MS-B
75MS	3/4	2-1/4	5/8	2-1/4	1-1/2	75MS-S	75MS-B

# HEXKEY EXTENSION ELBOWS

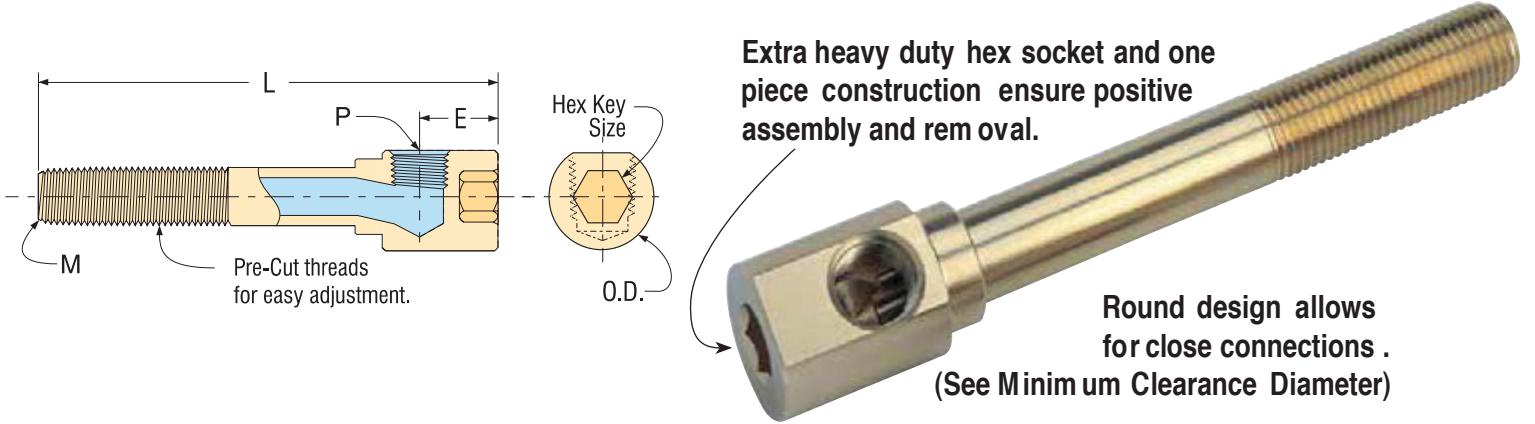

CATALOG NUMBER	P1 TAP SIZE FEMALE (NPT)	P2 TAP SIZE FEMALE (NPT)	L	E	O.D.	MINIMUM CLEARANCE DIAMETER	HEX KEY SIZE
HKL16	1/16	1/16	1.125	0.531	0.552	9/16	1/4
HKL18	1/8	1/8	1.250	0.580	0.615	5/8	5/16
HKL1814	1/8	1/4	1.375	0.593	0.860	7/8	3/8
HKL14	1/4	1/4	1.500	0.660	0.860	7/8	3/8
HKL1438	1/4	3/8	1.625	0.712	0.985	1"	1/2
HKL38	3/8	3/8	1.750	0.780	0.985	1"	1/2
HKL50	1/2	1/2	2.125	0.940	1.235	1-1/4	1/2

HexKey Extension Elbows are round, and install with an Allen wrench. Wrench clearance is not required, making these elbows ideal for use inside the mold, or anywhere space is limited.

- > Angular flow path allows connecting pipe fittings to be torqued tight without choking off flow.
- > Accurate length adjustments are easy with the Brass Extension Plug thread system.

> To order, add overall length to catalog number. Example: EKL16X025

# HEX ELBOWS

CATALOG NUMBER	P TAP SIZE FEMALE (NPT)	M PIPE SIZE MALE (NPT)	E	O.D.	MINIMUM CLEARANCE DIAMETER	HEX KEY SIZE	OVERALL LENGTH "L"							
							2-1/2	4"	5-1/2	7"	8-1/2	10"	11-1/2	13"
EKL16	1/16	1/16	0.531	0.552	9/16	1/4	X025	X040	X055	X070	X085	X100	X115	X130
EKL18	1/8	1/8	0.580	0.615	5/8	5/16	X025	X040	X055	X070	X085	X100	X115	X130
EKL14	1/4	1/4	0.660	0.860	7/8	3/8	X025	X040	X055	X070	X085	X100	X115	X130
EKL38	3/8	3/8	0.780	0.985	1"	1/2	X025	X040	X055	X070	X085	X100	X115	X130
EKL50	1/2	1/2	0.940	1.235	1-1/4	1/2	X025	X040	X055	X070	X085	X100	X115	X130

- > Angular coolant path prevents fitting interference at assembly and guarantees full flow. (See Drawing)
- > Compact, round design allows for close connections. (See Minimum Clearance Diameter)



# HEXKEY EXTENSION PIPES

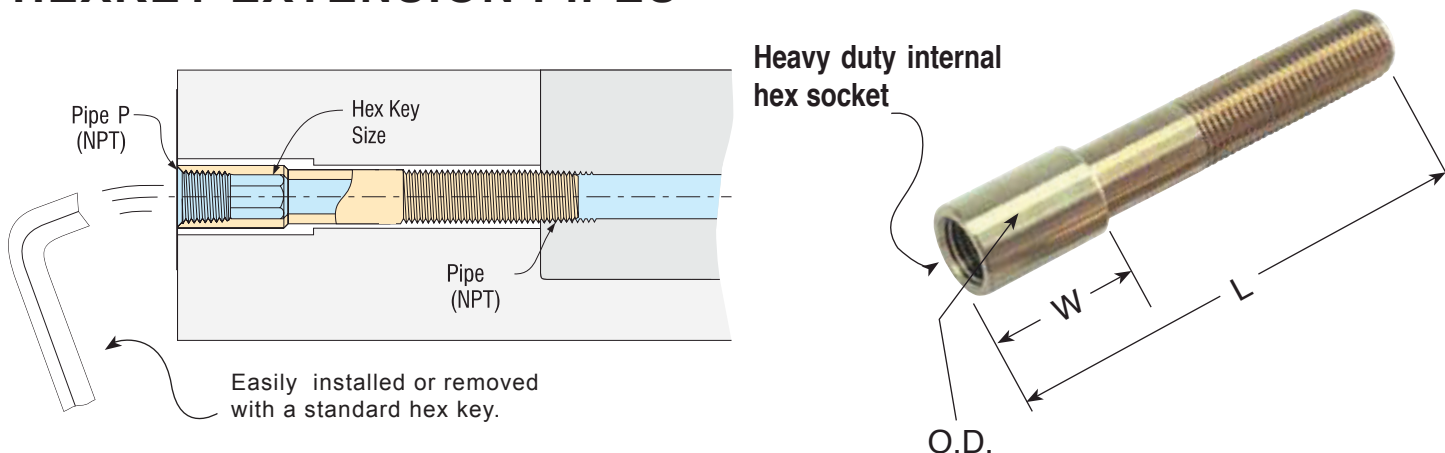

CATALOG NUMBER	P TAP SIZE FEMALE (NPT)	M PIPE SIZE MALE (NPT)	W	O.D.	HEX KEY SIZE	OVERALL LENGTH "L"				
						2-1/2	4"	5-1/2	7"	8-1/2
EP18	1/8	1/8	3/4	1/2	1/4	X025	X040	X055	X070	X085
EP14	1/4	1/4	1"	11/16	3/8	X025	X040	X055	X070	X085
EP38	3/8	3/8	1-1/4	13/16	1/2	X025	X040	X055	X070	X085
EP50	1/2	1/2	1-1/2	1"	9/16	X025	X040	X055	X070	X085

- > HexKey Extension Pipes are available in a wide variety of special lengths and threads.
- > Accurate length adjustments are easy with the Brass Extension Plug thread system.

> To order, add overall length to catalog number. Example: EP18X025

# HEXKEY STREET ELBOWS

CATALOG NUMBER	P1 TAP SIZE FEMALE (NPT)	P2 PIPE SIZE MALE (NPT)	L	E	O.D.	MINIMUM CLEARANCE DIAMETER	HEX KEY SIZE
KL16	1/16	1/16	1.156	0.531	0.552	9/16	1/4
KL1618	1/16	1/8	1.218	0.531	0.615	5/8	5/16
KL18	1/8	1/8	1.312	0.580	0.615	5/8	5/16
KL1814	1/8	1/4	1.500	0.593	0.860	7/8	3/8
KL14	1/4	1/4	1.625	0.660	0.860	7/8	3/8
KL1438	1/4	3/8	1.625	0.712	0.985	1"	1/2
KL38	3/8	3/8	1.750	0.780	0.985	1"	1/2
KL50	1/2	1/2	2.250	0.940	1.235	1-1/4	1/2

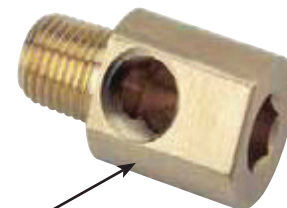

Extra heavy duty hex socket allows maximum assembly torque and positive removal.

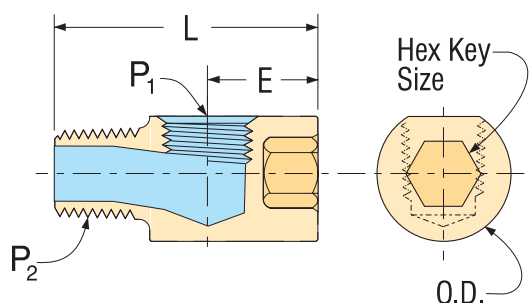

- > HexKey Street Elbows install with an Allen wrench for positive assembly and removal.
- > Angular coolant path allows connecting fittings to be torqued tight without choking off flow.

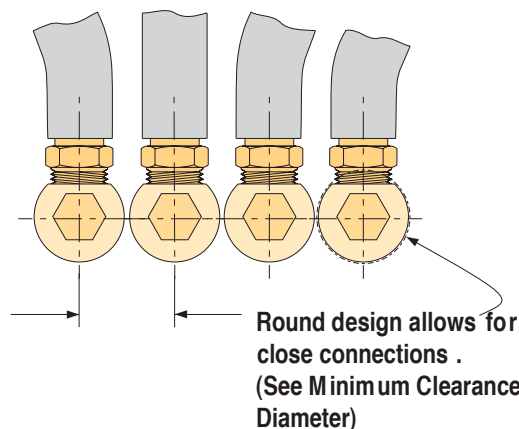



# ADJUSTABLE HEX NIPPLES

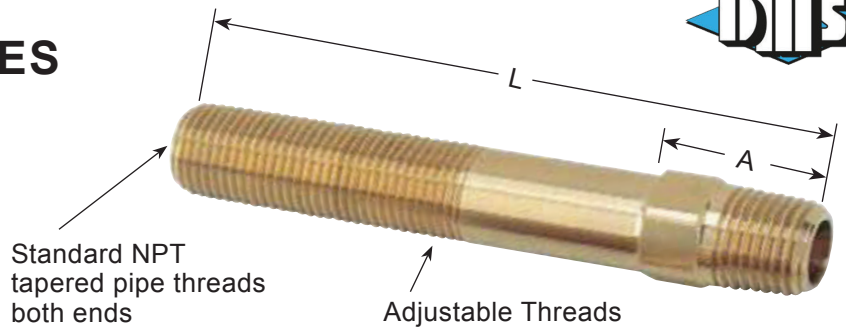
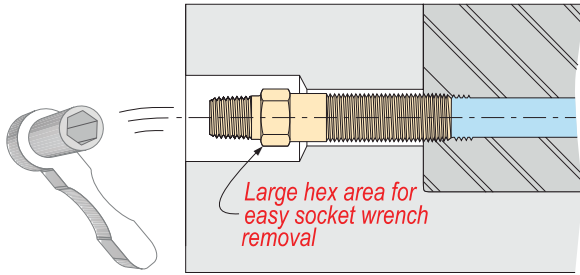

- ▶ Especially useful when installing Cascade Heads, Hex Elbows, etc.
- ▶ Longer or special lengths are available.
- ▶ Available in special thread combinations.

NUMBER	SIZE (NPT)	A	SIZE	2-1/2"	4"	5-1/2"	7"	8-1/2"	10"	11-1/2"	13"
APN16	1/16	11/16	3/8	X025	X040	X055	X070	X085	X100	X115	X130
APN18	1/8	3/4	7/16	X025	X040	X055	X070	X085	X100	X115	X130
APN14	1/4	7/8	9/16	X025	X040	X055	X070	X085	X100	X115	X130
APN38	3/8	1"	11/16	X025	X040	X055	X070	X085	X100	X115	X130
APN12	1/2	1-3/8	7/8	X025	X040	X055	X070	X085	X100	X115	X130

▶ To order, add overall length to catalog number. Example: APN16X025

# BRASS PIPE NIPPLES



CATALOG NUMBER	PIPE SIZE (NPT)	OVERALL LENGTH																
		CLOSE	1-1/2"	2"	2-1/2"	3"	3-1/2"	4"	4-1/2"	5"	5-1/2"	6"	7"	8"	9"	10"	11"	12"
BPN16	1/16	X000	X015	X020	X025	X030	X035	X040	X045	X050	X055	X060	X070	X080	X090	X100	X110	X120
BPN18	1/8	X000	X015	X020	X025	X030	X035	X040	X045	X050	X055	X060	X070	X080	X090	X100	X110	X120
BPN14	1/4	X000	X015	X020	X025	X030	X035	X040	X045	X050	X055	X060	X070	X080	X090	X100	X110	X120
BPN38	3/8	X000	X015	X020	X025	X030	X035	X040	X045	X050	X055	X060	X070	X080	X090	X100	X110	X120
BPN12	1/2	X000	X015	X020	X025	X030	X035	X040	X045	X050	X055	X060	X070	X080	X090	X100	X110	X120

▶ To order, add overall length to catalog number. Example: BPN16X025

# GALVANIZED PIPE NIPPLES



CATALOG NUMBER	PIPE SIZE (NPT)	OVERALL LENGTH																
		CLOSE	1-1/2"	2"	2-1/2"	3"	3-1/2"	4"	4-1/2"	5"	5-1/2"	6"	7"	8"	9"	10"	11"	12"
GPN16*	1/16	X000	X015	X020	X025	X030	X035	X040	X045	X050	X055	X060	X070	X080	X090	X100	X110	X120
GPN18	1/8	X000	X015	X020	X025	X030	X035	X040	X045	X050	X055	X060	X070	X080	X090	X100	X110	X120
GPN14	1/4	X000	X015	X020	X025	X030	X035	X040	X045	X050	X055	X060	X070	X080	X090	X100	X110	X120
GPN38	3/8	X000	X015	X020	X025	X030	X035	X040	X045	X050	X055	X060	X070	X080	X090	X100	X110	X120
GPN12	1/2	X000	X015	X020	X025	X030	X035	X040	X045	X050	X055	X060	X070	X080	X090	X100	X110	X120

- ▶ To order, add overall length to catalog number. Example: GPN16X025
- ▶ \* 1/16 pipe nipples are stainless steel.

## PUSH-LOK HOSE BARBS

CATALOG NUMBER	HOSE I.D.	PIPE SIZE (NPT)
PLM-04-02	1/4	1/8
PLM-04-04	1/4	1/4
PLM-06-02	3/8	1/8
PLM-06-04	3/8	1/4
PLM-08-04	1/2	1/4
PLM-08-06	1/2	3/8
PLM-08-08	1/2	1/2
PLM-08-12	1/2	3/4
PLM-12-08	3/4	1/2
PLM-12-12	3/4	3/4

- › All Push-Lok Hose fittings are constructed of brass and do not require hose clamps when used with Push-Lok hose.
- › Flow diameters are maximized for improved flow rates.



## SAFETY CLIPS



- › Safety Clips reduce the possibility of the accidental release of waterline sockets.
- › These clips are colour coded red or blue to designate hot and cold waterlines.
- › Fits equivalent and comparable waterline sockets.

CATALOG NUMBER	FITS SOCKET SERIES
5 C200 EB/R	S204 thru S226
5 C300	S306 thru S328
5 C500	S504 thru S526

- › To order, specify Catalog number and colour: Example C200-B



# FITTINGS & ACCESSORIES

## REDUCING BUSHINGS



CATALOG NUMBER	PIPE SIZE
RB18-1	1/8 X 1/16
RB14-2	1/4 X 1/8
RB38-4	3/8 X 1/4
RB50-6	1/2 X 3/8
RB75-8	3/4 X 1/2

## MALE HOSE BARBS



CATALOG NUMBER	HOSE I.D.	PIPE SIZE
MB14-2	1/4	1/8
MB14-4	1/4	1/4
MB15-2	5/16	1/8
MB15-4	5/16	1/4
MB38-2	3/8	1/8
MB38-4	3/8	1/4
MB50-4	1/2	1/4
MB50-6	1/2	3/8
MB50-8	1/2	1/2
MB75-8	3/4	1/2
MB75-12	3/4	3/4

## MALE REDUCERS

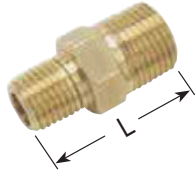

CATALOG NUMBER	PIPE SIZE	L
MR18-1	1/8 X 1/16	1"
MR14-2	1/4 X 1/8	1-3/16
MR38-4	3/8 X 1/4	1-7/16
MR50-6	1/2 X 3/8	1-5/8

## FEMALE HOSE BARBS



CATALOG NUMBER	HOSE I.D.	PIPE SIZE
FB14-2	1/4	1/8
FB14-4	1/4	1/4
FB15-4	5/16	1/4
FB38-2	3/8	1/8
FB38-4	3/8	1/4
FB50-6	1/2	3/8
FB50-8	1/2	1/2

## 45° STREET EL'S



CATALOG NUMBER	PIPE SIZE
AL-18	1/8
AL-14	1/4
AL-38	3/8
AL-50	1/2

## HOSE SPLICERS



CATALOG NUMBER	HOSE I.D.
HS-14	1/4 X 1/4
HS-38	3/8 X 3/8
HS-50	1/2 X 1/2

## 90° STREET EL'S

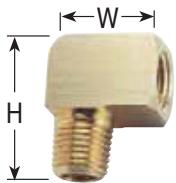

CATALOG NUMBER	PIPE SIZE	W	H
SL-18	1/8	11/16	15/16
SL-14	1/4	1"	1-1/4
SL-38	3/8	1-1/8	1-3/8
SL-50	1/2	1-1/2	1-3/4

## HEX COUPLINGS



CATALOG NUMBER	PIPE SIZE
C-18	1/8
C-14	1/4
C-38	3/8
C-50	1/2

## 90° ELBOWS

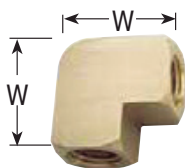

CATALOG NUMBER	PIPE SIZE	W
EL-18	1/8	13/16
EL-14	1/4	1-1/8
EL-38	3/8	1-1/4
EL-50	1/2	1-9/16

## HOSE CLAMPS



CATALOG NUMBER	MAX. HOSE O.D.
HC-58	5/8
HC-78	7/8
HC-118	1-1/8

## TEES

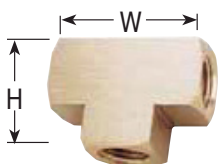

CATALOG NUMBER	PIPE SIZE	W	H
T-18	1/8	1-1/16	13/16
T-14	1/4	1-1/2	1-1/8
T-38	3/8	1-11/16	1-1/4
T-50	1/2	2-1/8	1-9/16

## TEFLON TAPE



CATALOG NUMBER	ROLL SIZE
TL-250	1/4 X 520"
TL-500	1/2 X 520"

## HEX NIPPLES

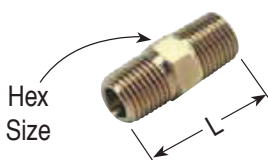

CATALOG NUMBER	PIPE SIZE	HEX SIZE	L
HN-18	1/8	7/16	31/32
HN-14	1/4	9/16	1-3/8
HN-38	3/8	11/16	1-7/16
HN-50	1/2	7/8	1-13/16

# FLOW THRU SOCKETS



**STRAIGHT**



**45°**



**90°**

## 200 SERIES

CAT. NO.	HOSE I.D.
S204	1/4
S205	5/16
S206	3/8
N/A	1/2
N/A	3/4

CAT. NO.	HOSE I.D.
S224	1/4
S225	5/16
S226	3/8
N/A	1/2
N/A	3/4

CAT. NO.	HOSE I.D.
S214	1/4
S215	5/16
S216	3/8
N/A	1/2
N/A	3/4

## 300 SERIES

CAT. NO.	HOSE I.D.
N/A	1/4
N/A	5/16
S306	3/8
S308	1/2
N/A	3/4

CAT. NO.	HOSE I.D.
N/A	1/4
N/A	5/16
S326	3/8
S328	1/2
N/A	3/4

CAT. NO.	HOSE I.D.
N/A	1/4
N/A	5/16
S316	3/8
S318	1/2
N/A	3/4

## 500 SERIES

CAT. NO.	HOSE I.D.
N/A	1/4
N/A	5/16
N/A	3/8
S504	1/2
S506	3/4

CAT. NO.	HOSE I.D.
N/A	1/4
N/A	5/16
N/A	3/8
S524	1/2
S526	3/4

CAT. NO.	HOSE I.D.
N/A	1/4
N/A	5/16
N/A	3/8
S514	1/2
S516	3/4

► Note: For "Push-Lok" hose barbs add PL to catalog number. Example S204PL

# VALVED SOCKETS



**STRAIGHT**



**45°**



**90°**

## 200 SERIES

CAT. NO.	HOSE I.D.
S204V	1/4
S205V	5/16
S206V	3/8
N/A	1/2
N/A	3/4

CAT. NO.	HOSE I.D.
S224V	1/4
S225V	5/16
S226V	3/8
N/A	1/2
N/A	3/4

CAT. NO.	HOSE I.D.
S214V	1/4
S215V	5/16
S216V	3/8
N/A	1/2
N/A	3/4

## 300 SERIES

CAT. NO.	HOSE I.D.
N/A	1/4
N/A	5/16
S306V	3/8
S308V	1/2
N/A	3/4

CAT. NO.	HOSE I.D.
N/A	1/4
N/A	5/16
S326V	3/8
S328V	1/2
N/A	3/4

CAT. NO.	HOSE I.D.
N/A	1/4
N/A	5/16
S316V	3/8
S318V	1/2
N/A	3/4

## 500 SERIES

CAT. NO.	HOSE I.D.
N/A	1/4
N/A	5/16
N/A	3/8
N/A	1/2
N/A	3/4

CAT. NO.	HOSE I.D.
N/A	1/4
N/A	5/16
N/A	3/8
N/A	1/2
N/A	3/4

CAT. NO.	HOSE I.D.
N/A	1/4
N/A	5/16
N/A	3/8
N/A	1/2
N/A	3/4

► Note: For "Push-Lok" hose barbs add PL to catalog number. Example S204VPL



# LOCKING COUPLERS

Internal Ball Bearing Action

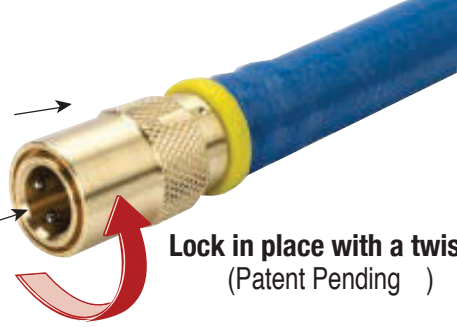

Maximum Flow

Lock in place with a twist  
(Patent Pending )

## FOR PUSH-LOK HOSE

- > No hose clamp required when used with Push-Lok hose.
- > Straight thru design for maximum flow rates.
- > Sleeve lock provides safety.
- > All brass and stainless steel construction.
- > Compatible with all mold connection systems.



STRAIGHT



45°



90°

## WITH STANDARD BARBS

- > Use hose clamps with these couplers.
- > Straight thru design for maximum flow rates.
- > Sleeve lock provides safety.
- > All brass and stainless steel construction.
- > Compatible with all mold connection systems.



STRAIGHT



45°



90°

## BODIES ONLY



Thread Size (NPT)



- > Flow-thru type.
- > Select pipe thread to suit your application.

### 200 SERIES (1/4" Hole)

CATALOG NUMBER	HOSE ID	STOCK ITEM
CM-204-PL	1/4	•
CM-205-PL	5/16	•
CM-206-PL	3/8	•

CATALOG NUMBER	HOSE ID	STOCK ITEM
CM-224-PL	1/4	•
CM-225-PL	5/16	•
CM-226-PL	3/8	•

CATALOG NUMBER	HOSE ID	STOCK ITEM
CM-214-PL	1/4	•
CM-215-PL	5/16	•
CM-216-PL	3/8	•

### 300 SERIES (3/8" Hole)

CATALOG NUMBER	HOSE ID	STOCK ITEM
CM-306-PL	3/8	•
CM-308-PL	1/2	•

CATALOG NUMBER	HOSE ID	STOCK ITEM
CM-326-PL	3/8	•
CM-328-PL	1/2	•

CATALOG NUMBER	HOSE ID	STOCK ITEM
CM-316-PL	3/8	•
CM-318-PL	1/2	•

### 500 SERIES (1/2" Hole)

CATALOG NUMBER	HOSE ID	STOCK ITEM
CM-504-PL	1/2	•
CM-506-PL	3/4	•

CATALOG NUMBER	HOSE ID	STOCK ITEM
CM-524-PL	1/2	•
CM-526-PL	3/4	•

CATALOG NUMBER	HOSE ID	STOCK ITEM
CM-514-PL	1/2	•
CM-516-PL	3/4	•

### 200 SERIES (1/4" Hole)

CATALOG NUMBER	HOSE ID	STOCK ITEM
CM-204	1/4	•
CM-205	5/16	•
CM-206	3/8	•

CATALOG NUMBER	HOSE ID	STOCK ITEM
CM-224	1/4	•
CM-225	5/16	•
CM-226	3/8	•

CATALOG NUMBER	HOSE ID	STOCK ITEM
CM-214	1/4	•
CM-215	5/16	•
CM-216	3/8	•

### 300 SERIES (3/8" Hole)

CATALOG NUMBER	HOSE ID	STOCK ITEM
CM-306	3/8	•
CM-308	1/2	•

CATALOG NUMBER	HOSE ID	STOCK ITEM
CM-326	3/8	•
CM-328	1/2	•

CATALOG NUMBER	HOSE ID	STOCK ITEM
CM-316	3/8	•
CM-318	1/2	•

### 500 SERIES (1/2" Hole)

CATALOG NUMBER	HOSE ID	STOCK ITEM
CM-504	1/2	•
CM-506	3/4	•

CATALOG NUMBER	HOSE ID	STOCK ITEM
CM-524	1/2	•
CM-526	3/4	•

CATALOG NUMBER	HOSE ID	STOCK ITEM
CM-514	1/2	•
CM-516	3/4	•

### 200 SERIES (1/4" Hole)

CATALOG NUMBER	THREAD SIZE	STOCK ITEM
CMB-200	1/8	•
CMB-200-1/4	1/4	•

### 300 SERIES (3/8" Hole)

CATALOG NUMBER	THREAD SIZE	STOCK ITEM
CMB-300	1/4	•
CMB-300-3/8	3/8	•

### 500 SERIES (1/2" Hole)

CATALOG NUMBER	THREAD SIZE	STOCK ITEM
CMB-500	1/2	•

## SOCKET BODY

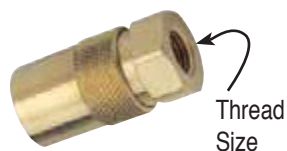

### 200 SERIES

CATALOG NUMBER	THREAD SIZE (NPT)
CMB-200-18	1/8
CMB-200-14	1/4

### 300 SERIES

CATALOG NUMBER	THREAD SIZE (NPT)
CMB-300-14	1/4
CMB-300-38	3/8

### 500 SERIES

CATALOG NUMBER	THREAD SIZE (NPT)
CMB-500-12	1/2

Socket bodies are flow-thru only.

## SEALS



### 200 SERIES

CATALOG NUMBER	SEAL MATERIAL
S-200-6	SILICONE
V-200-6	VITON

### 300 SERIES

CATALOG NUMBER	SEAL MATERIAL
S-300-6	SILICONE
V-300-6	VITON

### 500 SERIES

CATALOG NUMBER	SEAL MATERIAL
S-500-6	SILICONE
V-500-6	VITON

## CONNECTOR PLUGS

### MALE (brass)

**NEW** BSP AVAILABLE



### 200 SERIES

CATALOG NUMBER	PIPE THREAD	FLOW DIA.
P250	1/16	3/16
P251	1/8	1/4
P252	1/4	1/4
P253	3/8	1/4

P251-BSP	1/8	1/4
P252-BSP	1/4	1/4

### 300 SERIES

CATALOG NUMBER	PIPE THREAD	FLOW DIA.
P351	1/8	1/4
P352	1/4	3/8
P353	3/8	3/8
P354	1/2	3/8

P351-BSP	1/8	1/4
P352-BSP	1/4	3/8
P353-BSP	3/8	3/8

### 500 SERIES

CATALOG NUMBER	PIPE THREAD	FLOW DIA.
P552	1/4	3/8
P553	3/8	1/2
P554	1/2	5/8
P556	3/4	5/8

P553-BSP	3/8	1/2
P554-BSP	1/2	5/8

### FEMALE (plated steel)



CATALOG NUMBER	PIPE THREAD	FLOW DIA.
P352F	1/4	3/8
P353F	3/8	3/8
P354F	1/2	3/8

### FEMALE (brass)

BSP AVAILABLE



CATALOG NUMBER	PIPE THREAD	FLOW DIA.
P250FB	1/16	1/4
P251FB	1/8	1/4
P252FB	1/4	1/4
P253FB	3/8	1/4

P251FB-BSP	1/8	1/4
P252FB-BSP	1/4	1/4

CATALOG NUMBER	PIPE THREAD	FLOW DIA.
P351FB	1/8	11/32
P352FB	1/4	3/8
P353FB	3/8	3/8
P354FB	1/2	3/8

P351FB-BSP	1/8	11/32
P352FB-BSP	1/4	3/8
P353FB-BSP	3/8	3/8

CATALOG NUMBER	PIPE THREAD	FLOW DIA.
P551FB	1/8	11/32
P552FB	1/4	7/16
P553FB	3/8	9/16
P554FB	1/2	5/8

P553FB-BSP	3/8	9/16
P554FB-BSP	1/2	5/8



# BRASS EXTENSION PLUGS

- > Extension Plugs are compatible with all major mold connection systems.
- > In addition to brass they can be ordered in stainless or plated steel.
- > Extension plugs are also available in all metric pipe sizes.

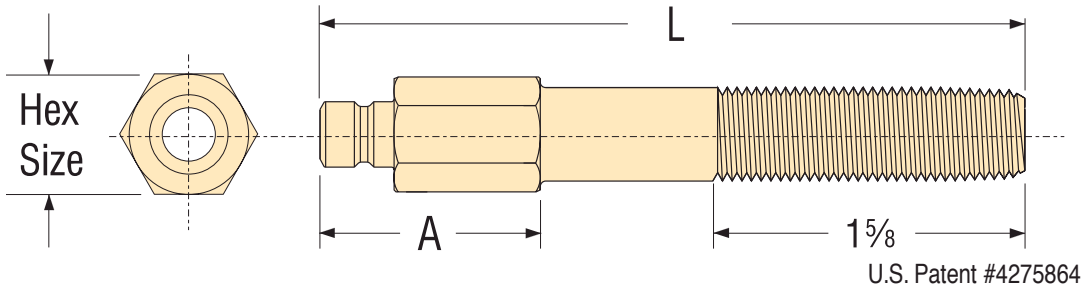
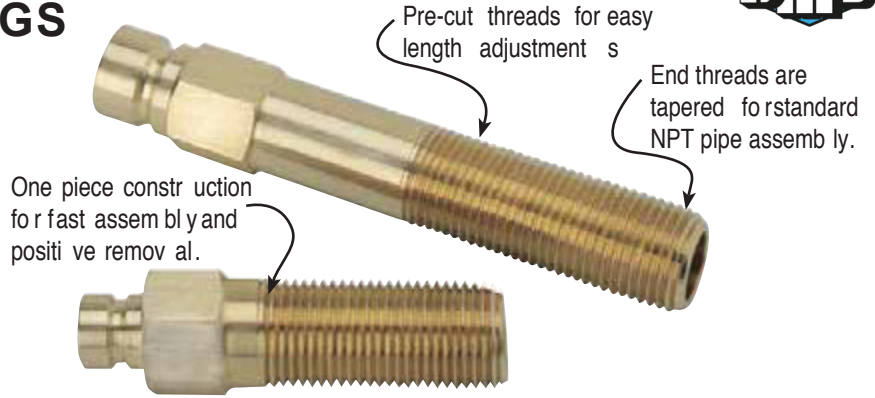

- > BSP Brass Extension Plugs now available
- > Available with pre-applied sealant.
- > Order any quantity.

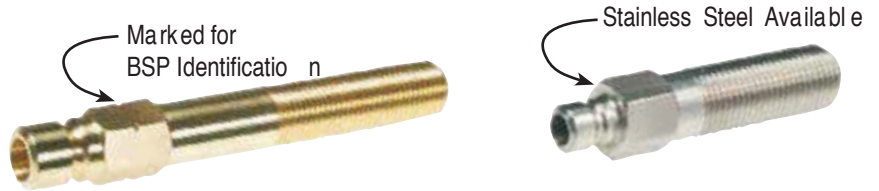

# LENGTH ADJUSTMENTS

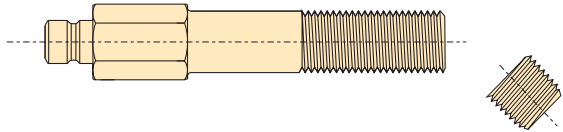

If special length adjustments are required, simply cut to length and chamfer the end.

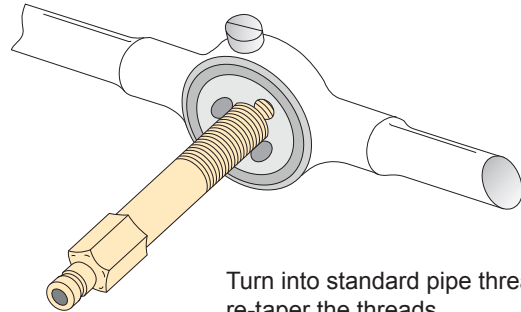

Turn into standard pipe threading die to re-taper the threads.

# INSTALLATION

CATALOG SERIES	C (DIA.)	D
250	3/4	1"
251	7/8	1-1/4
252	1"	1-1/2
253	1-1/8	1-1/2
350	1"	1-1/4
351	1"	1-1/4
352	1"	1-1/2
353	1-1/8	1-1/2
354	1-1/2	1-3/4
553	1-3/8	1-5/8
554	1-1/2	1-3/4

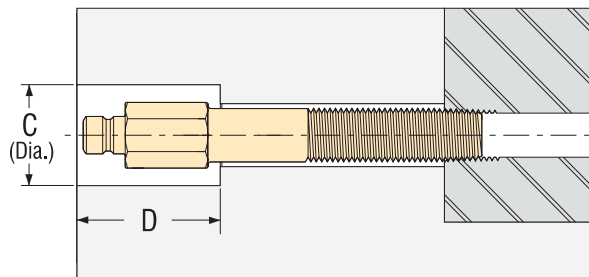

At assembly, the tapered brass threads provide a dependable, leak proof seal. With one-piece construction, removing the plug is guaranteed.



# BRASS EXTENSION PLUGS

## 200 SERIES

## 300 SERIES

## 500 SERIES

CAT. NO.	L OVERALL LENGTH (INCHES)	PIPE SIZE (NPT)	HEX SIZE	A
<b>1/16" Pipe Extensions</b>				
P250X025	2-1/2	1/16	3/8	11/16
P250X040	4	1/16	3/8	13/16
P250X055	5-1/2	1/16	3/8	13/16
P250X070	7	1/16	3/8	13/16
<b>1/8" Pipe Extensions</b>				
P251X025	2-1/2	1/8	7/16	11/16
P251X040	4	1/8	7/16	1"
P251X055	5-1/2	1/8	7/16	1"
P251X070	7	1/8	7/16	1"
P251X085	8-1/2	1/8	7/16	1"
P251X100	10	1/8	7/16	1"
P251X115	11-1/2	1/8	7/16	1"
P251X130	13	1/8	7/16	1"
<b>1/4" Pipe Extensions</b>				
P252X025	2-1/2	1/4	9/16	7/8
P252X040	4	1/4	9/16	1-1/4
P252X055	5-1/2	1/4	9/16	1-1/4
P252X070	7	1/4	9/16	1-1/4
P252X085	8-1/2	1/4	9/16	1-1/4
P252X100	10	1/4	9/16	1-1/4
P252X115	11-1/2	1/4	9/16	1-1/4
P252X130	13	1/4	9/16	1-1/4
<b>3/8" Pipe Extensions</b>				
P253X025	2-1/2	3/8	11/16	1"
P253X040	4	3/8	11/16	1-1/4
P253X055	5-1/2	3/8	11/16	1-1/4
P253X070	7	3/8	11/16	1-1/4
P253X085	8-1/2	3/8	11/16	1-1/4
P253X100	10	3/8	11/16	1-1/4
P253X115	11-1/2	3/8	11/16	1-1/4
P253X130	13	3/8	11/16	1-1/4
<b>1/2" Pipe Extensions</b>				
CUSTOM				

CAT. NO.	L OVERALL LENGTH (INCHES)	PIPE SIZE (NPT)	HEX SIZE	A
<b>1/16" Pipe Extensions</b>				
P350X025	2-1/2	1/16	9/16	7/8
P350X040	4	1/16	9/16	1"
P350X055	5-1/2	1/16	9/16	1"
P350X070	7	1/16	9/16	1"
<b>1/8" Pipe Extensions</b>				
P351X025	2-1/2	1/8	9/16	7/8
P351X040	4	1/8	9/16	1"
P351X055	5-1/2	1/8	9/16	1"
P351X070	7	1/8	9/16	1"
P351X085	8-1/2	1/8	9/16	1"
P351X100	10	1/8	9/16	1"
P351X115	11-1/2	1/8	9/16	1"
P351X130	13	1/8	9/16	1"
<b>1/4" Pipe Extensions</b>				
P352X025	2-1/2	1/4	9/16	7/8
P352X040	4	1/4	9/16	1-1/4
P352X055	5-1/2	1/4	9/16	1-1/4
P352X070	7	1/4	9/16	1-1/4
P352X085	8-1/2	1/4	9/16	1-1/4
P352X100	10	1/4	9/16	1-1/4
P352X115	11-1/2	1/4	9/16	1-1/4
P352X130	13	1/4	9/16	1-1/4
<b>3/8" Pipe Extensions</b>				
P353X025	2-1/2	3/8	11/16	1"
P353X040	4	3/8	11/16	1-1/4
P353X055	5-1/2	3/8	11/16	1-1/4
P353X070	7	3/8	11/16	1-1/4
P353X085	8-1/2	3/8	11/16	1-1/4
P353X100	10	3/8	11/16	1-1/4
P353X115	11-1/2	3/8	11/16	1-1/4
P353X130	13	3/8	11/16	1-1/4
<b>1/2" Pipe Extensions</b>				
P354X025	2-1/2	1/2	7/8	1-1/8
P354X040	4	1/2	7/8	1-1/2
P354X055	5-1/2	1/2	7/8	1-1/2
P354X070	7	1/2	7/8	1-1/2
P354X085	8-1/2	1/2	7/8	1-1/2
P354X100	10	1/2	7/8	1-1/2
P354X115	11-1/2	1/2	7/8	1-1/2
P354X130	13	1/2	7/8	1-1/2

CAT. NO.	L OVERALL LENGTH (INCHES)	PIPE SIZE (NPT)	HEX SIZE	A
<b>1/16" Pipe Extensions</b>				
CUSTOM				
<b>1/8" Pipe Extensions</b>				
CUSTOM				
<b>1/4" Pipe Extensions</b>				
CUSTOM				
<b>3/8" Pipe Extensions</b>				
P553X025	2-1/2	3/8	13/16	1-1/8
P553X040	4	3/8	13/16	1-3/8
P553X055	5-1/2	3/8	13/16	1-3/8
P553X070	7	3/8	13/16	1-3/8
P553X085	8-1/2	3/8	13/16	1-3/8
P553X100	10	3/8	13/16	1-3/8
P553X115	11-1/2	3/8	13/16	1-3/8
P553X130	13	3/8	13/16	1-3/8
<b>1/2" Pipe Extensions</b>				
P554X025	2-1/2	1/2	7/8	1-1/8
P554X040	4	1/2	7/8	1-1/2
P554X055	5-1/2	1/2	7/8	1-1/2
P554X070	7	1/2	7/8	1-1/2
P554X085	8-1/2	1/2	7/8	1-1/2
P554X100	10	1/2	7/8	1-1/2
P554X115	11-1/2	1/2	7/8	1-1/2
P554X130	13	1/2	7/8	1-1/2



# QUICK-COUPLER WATER JUMPERS

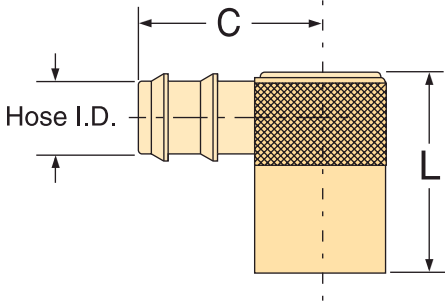

Oversized and unrestricted flow path maintains full flow rate of hose used.



For use with Push-Lok hose, no hose clamps are required



Coupler sleeve twists to lock, preventing accidental disconnect.

CATALOG NUMBER	FITS PLUG SERIES	HOSE I.D.	L	C	M	A
WJ200-4	200	1/4	1"	1-1/4	3/8	5/8
WJ200-5	200	5/16	1"	1-1/4	3/8	5/8
WJ200-6	200	3/8	1"	1-1/4	3/8	5/8
WJ300-6	300	3/8	1-7/16	1-9/16	1/2	7/8
WJ300-8	300	1/2	1-7/16	1-9/16	1/2	7/8
WJ500-8	500	1/2	2-1/8	2"	7/8	1-1/8
WJ500-12	500	3/4	2-1/8	2"	7/8	1-1/8

## 500 SERIES

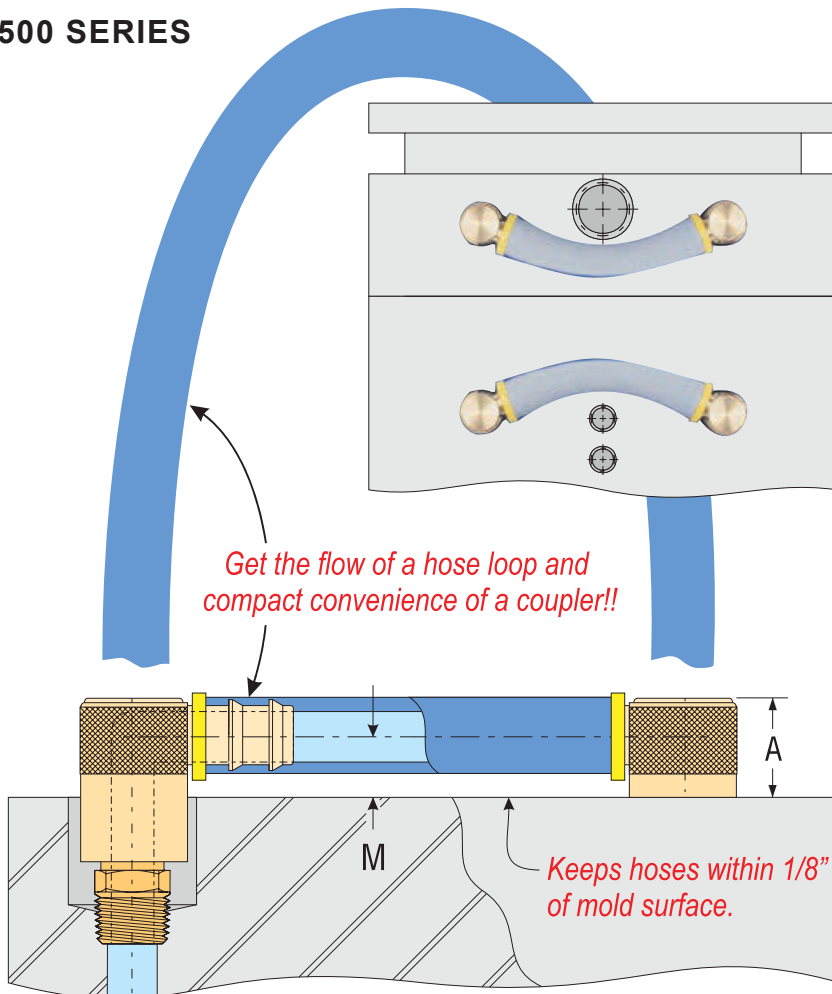

- Eliminates bulky hose loops.
- Compact design neatly and safely holds cooling lines close to the mold surface.
- Stock only one part number for any hose size. No special tubes or length restrictions.
- Compatible with all major mold connection systems.
- Unlimited installation options. Fits around obstacles, and installs in compact spaces.
- Viton seals for temperatures up to 400°F.
- All brass and stainless steel construction.

# SWIVEL WATER JUMPERS

- Can be fully recessed to prevent accidental disconnect or damage.
- Swivel body allows installation in tight spaces.
- Eliminate crimped hoses and setup errors.
- Supplied with Viton O-Ring seals.
- All brass construction.
- Hex key installation.
- Custom length Jumpers can be quoted.

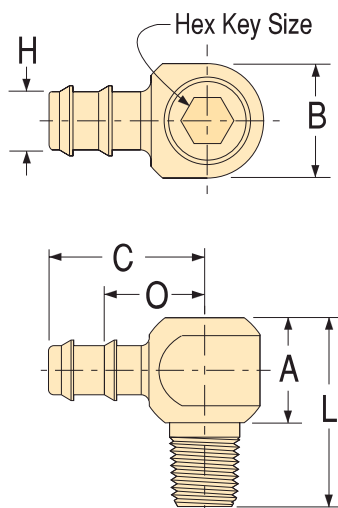

Heavy duty hex key socket allows maximum torque and positive removal.



Threads can be adjusted to specific lengths.

CATALOG NUMBER	PIPE SIZE (NPT)	H HOSE I.D.	HEX KEY SIZE	L	A	C	O	B	MIN. SLOT WIDTH	MIN. SLOT DEPTH
WJ18-S	1/8	5/16	3/16	1-3/16	11/16	1"	5/8	0.660	11/16	1"
WJ18-M	1/8	5/16	3/16	2"	11/16	1"	5/8	0.660	11/16	1"
WJ18-L	1/8	5/16	3/16	3-1/2	11/16	1"	5/8	0.660	11/16	1"
WJ14-S	1/4	3/8	1/4	1-7/16	13/16	1-3/16	25/32	0.840	7/8	1-3/16
WJ14-M	1/4	3/8	1/4	2-3/8	13/16	1-3/16	25/32	0.840	7/8	1-3/16
WJ14-L	1/4	3/8	1/4	3-7/8	13/16	1-3/16	25/32	0.840	7/8	1-3/16
WJ38-S	3/8	1/2	5/16	1-5/8	1"	1-3/8	15/16	0.980	1"	1-3/8
WJ38-M	3/8	1/2	5/16	2-5/8	1"	1-3/8	15/16	0.980	1"	1-3/8
WJ38-L	3/8	1/2	5/16	4-1/8	1"	1-3/8	15/16	0.980	1"	1-3/8
WJ50-S	1/2	3/4	3/8	2"	1-1/8	1-1/2	1-1/8	1.235	1-1/4	1-9/16
WJ50-M	1/2	3/4	3/8	3"	1-1/8	1-1/2	1-1/8	1.235	1-1/4	1-9/16
WJ50-L	1/2	3/4	3/8	4-1/2	1-1/8	1-1/2	1-1/8	1.235	1-1/4	1-9/16

Flow Data

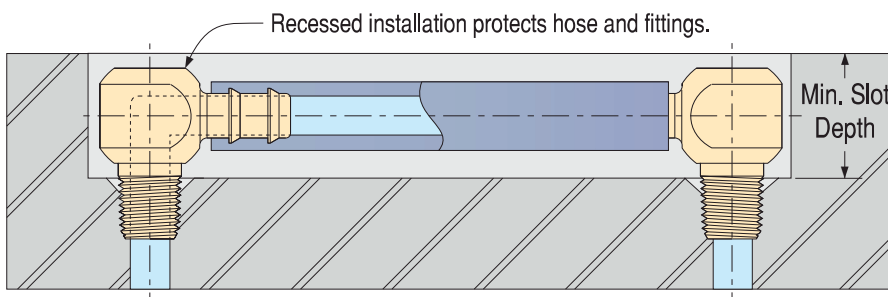
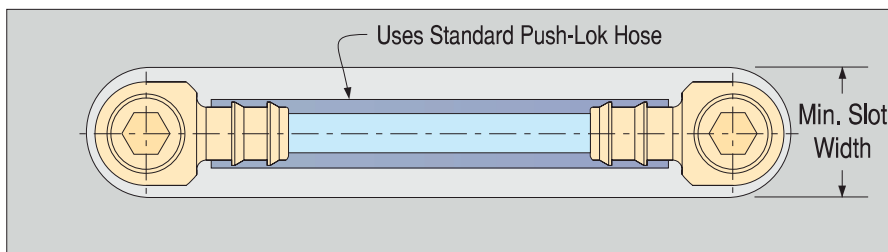
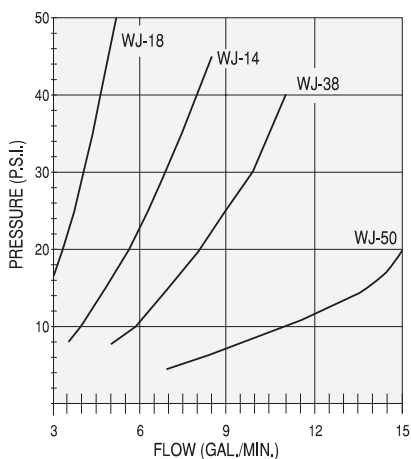

# PRESSURE PLUGS



## THREADLESS PLUGS

- ▶ Threadless plugs utilize an expandable O-ring to create a positive seal.
- ▶ Seals rough or corroded holes.
- ▶ Withstands pressures up to 72 psi.
- ▶ No tapping is required.



CATALOG NUMBER	NOMINAL SIZE	HEIGHT	HEX SIZE	DRILL SIZE	O-RING CATALOG NUMBER
TBPP012	1/8	0.50	5/64	11/32	OR-012
TBPP025	1/4	0.56	1/8	7/16	OR-025
TBPP037	3/8	0.62	1/8	9/16	OR-037
TBPP050	1/2	0.62	1/8	11/16	OR-050
TBPP012-OS	1/8	0.50	5/64	23/64	OR-012
TBPP025-OS	1/4	0.56	1/8	29/64	OR-025
TBPP037-OS	3/8	0.62	1/8	37/64	OR-037
TBPP050-OS	1/2	0.62	1/8	45/64	OR-050

THREAD SIZE (NPT)	TPI	FLUSH HEIGHT	CATALOG NUMBER		
			BRASS	ALLOY STEEL	STAINLESS STEEL
1/16	27	0.250	BPP006	APP006	SPP006
1/8	27	0.250	BPP012	APP012	SPP012
1/4	18	0.406	BPP025	APP025	SPP025
3/8	18	0.406	BPP037	APP037	SPP037
1/2	14	0.531	BPP050	APP050	SPP050
3/4	14	0.531	BPP075	APP075	
1"	11-1/2	0.656	BPP100	APP100	
1-1/4	11-1/2	0.656	BPP125		
1-1/2	11-1/2	0.656	BPP150		

- ▶ Standard plugs are flush type (7/8" taper per foot).
- ▶ Oversize plugs are (Dry Seal). To order add -O/S to catalog number.

## O-RING PLUGS

CATALOG NUMBER	R REAM SIZE	B (+.000) (-.005)	D (+.005) (-.000)	REMOVAL THREAD SIZE
OR-06	0.281	1/4	0.250	6-32
OR-12	0.375	5/16	0.312	10-32
OR-25	0.500	5/16	0.312	10-32
OR-38	0.625	7/16	0.437	1/4-20
OR-50	0.750	1/2	0.500	1/4-20
OR-75	1.000	5/8	0.625	3/8-16



- ▶ O-Ring plugs are used when backed up by other mold inserts, holder block, etc.
- ▶ They require less space than NPT pressure plugs. Less inter-ferece in tight spaces.
- ▶ Standard Buna O-Ring provides seal to 210° Farenheit.
- ▶ Viton O-rings and quad rings are available.

## HEAVY DUTY PLUGS

CATALOG NUMBER	THREAD SIZE (NPT)
XTBF-006	1/16
XTBF-012	1/8
XTBF-025	1/4
XTBF-037	3/8
XTBF-050	1/2
XTBF-075	3/4

- ▶ Standard brass flush seal plugs with **XT** forming technology for maximum wrenching torque.
- ▶ Extra deep socket can't "round out" when plugs are installed or removed.
- ▶ Order in any quantity.

With Patented **XT** Technology...

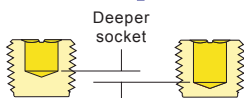

Extra deep socket is stronger, and will not strip out.



## BSP PLUGS

CATALOG NUMBER	THREAD SIZE (NPT)
MP-012BSP	1/8-28
MP-025BSP	1/4-19
MP-037BSP	3/8-19
MP-050BSP	1/2-14
MP-075BSP	3/4-14
MP-100BSP	1-11

- ▶ Fits BSPT and BSPP threaded holes.
- ▶ Features extra deep socket for strength.
- ▶ Order in any quantity.



## STOP PLUGS

CATALOG NUMBER	FITS SOCKET SERIES NUMBER
CP-200	200
CP-300	300
CP-500	500



- ▶ Stops coolant flow on hoses with flow-thru sockets.
- ▶ Prevents accidents by plugging unused hoses and manifold ports.
- ▶ Keeps couplers and seals clean when not in use.

# PIPE PLUG DIVERTERS

Pipe plug is pre-assembled to locating rod and swivels for positive installation and removal.

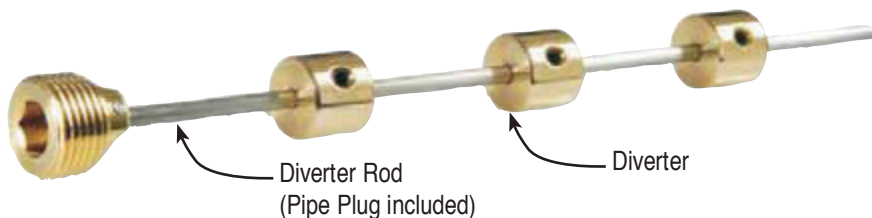

CATALOG NUMBER	PIPE SIZE	L	ROD DIA.	DIVERTER NUMBER
DR-125	1/8	12	3/32	D-125
DR-250	1/4	18	1/8	D-250
DR-375	3/8	18	1/8	D-375
DR-500	1/2	24	3/16	D-500
DR-750	3/4	24	3/16	D-750

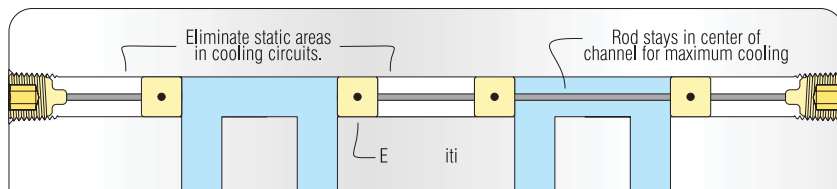

- > No special tools needed.
- > Simply lock diverters in position on the stainless rod, and install into the cooling chamber.
- > Rod stays in the center of the cooling channel, allowing maximum heat transfer to coolant.
- > Choose the pipe size and length from the chart. Then choose diverter. Longer length diverter rods are available.



## DIVERTERS



CATALOG NUMBER	PIPE SIZE	O.D. (-.005)	B	FITS ROD DIA.
D-125	1/8	0.340	3/8	3/32
D-250	1/4	0.432	7/16	1/8
D-375	3/8	0.557	1/2	1/8
D-500	1/2	0.682	3/4	3/16
D-750	3/4	0.932	3/4	3/16

- > Locking screw included.
- > Custom sizes available.
- > Order in any quantity.

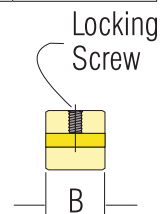

# COMBINATION HOSE INSERTS

Eliminates multiple fittings and assembly. Put a Combination Hose Insert on one end of a hose, and a coupler on the other. Hoses may then be snapped together in series.

- > All flow diameters are maximized to reduce restrictions.
- > For use with Push-Lok or standard hose.

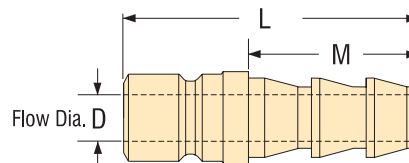

## 200 SERIES

## 300 SERIES

## 500 SERIES

CATALOG NUMBER	HOSE I.D.	D	M	L
CH200-4	1/4	3/16	7/8	1-3/8
CH200-5	5/16	1/4	7/8	1-3/8
CH200-6	3/8	1/4	1-1/16	1-9/16
CH200-8	1/2	1/4	1-1/16	1-9/16

CATALOG NUMBER	HOSE I.D.	D	M	L
CH300-4	1/4	3/16	7/8	1-13/16
CH300-5	5/16	1/4	7/8	1-13/16
CH300-6	3/8	9/32	1-1/16	1-13/16
CH300-8	1/2	11/32	1-1/16	1-13/16

CATALOG NUMBER	HOSE I.D.	D	M	L
CH500-8	1/2	13/32	1-1/16	2"
CH500-12	3/4	9/16	1-1/2	2-1/2

# ISOBAR® HEAT PIPES

An **Isobar® Heat Pipe** is a super-thermal conductor that has the capacity to transfer large amounts of heat at high speeds in both heating and cooling applications. In fact, Isobar® Heat Pipes have, in some applications and orientations, a thermal conductivity in excess of 10,000 times the rate of a solid copper bar of the same geometry. The working fluid constantly changes phase due to the low vapor pressure inside the unit.

The resulting pressure difference moves the vapor from the heated end to colder area where it condenses and releases the heat energy uniformly. Isobars® are most successfully used horizontally. Special designs for vertical use are available to order.

**Isobars®** are used instead of conventional water-cooling methods. They can simplify tool design and are easy to fit. They are designed to operate over the range of mold operating temperatures between 35°F and 500°F. For relevant hole dimensions, please see chart below.

**Isobar® Heat Pipes** can be designed or retrofitted into many molding applications to improve efficiency related to cycle times, cure rates, mold temperature uniformity, set-up times and recovery rate. The cooled length should be a minimum of 50% of heated length for maximum efficiency.

DMS can manufacture your core pin and have Isobars® charged directly to the core pin.

DIAMETER	DRILL (IN.)	TOLERANCE (HIGH)	TOLERANCE (LOW)
3/32	0.096	+0.001	-0.001
1/8	0.127	+0.001	-0.001
5/32	0.157	+0.001	-0.001
3/16	0.189	+0.001	-0.001
7/32	0.219	+0.001	-0.001
1/4	0.252	+0.001	-0.001
5/16	0.314	+0.001	-0.001
3/8	0.377	+0.001	-0.001
1/2	0.502	+0.001	-0.001

DIAMETER	DRILL (mm)	TOLERANCE (HIGH)	TOLERANCE (LOW)
3mm	3.07	+0.03	-0.03
4mm	4.04	+0.03	-0.03
5mm	5.08	+0.03	-0.03
6mm	6.05	+0.03	-0.03
8mm	8.05	+0.03	-0.03
10mm	10.01	+0.03	-0.03
12mm	11.96	+0.03	-0.03
15mm	14.96	+0.03	-0.03
16mm	16.08	+0.03	-0.03
18mm	17.98	+0.03	-0.03
20mm	19.94	+0.03	-0.03
25mm	24.94	+0.03	-0.03
30mm	29.95	+0.03	-0.03

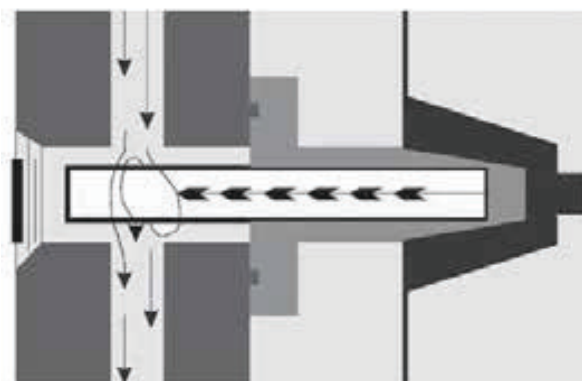
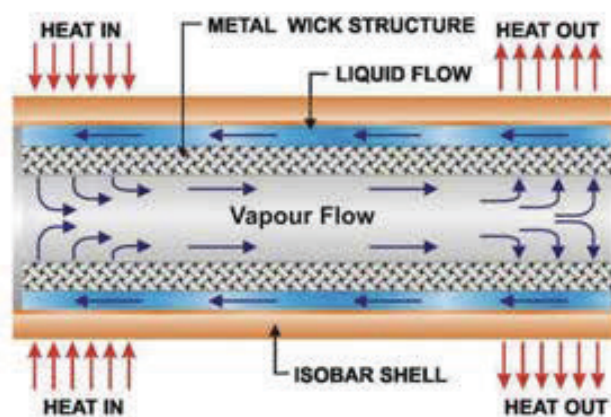

ISOBAR IN USE

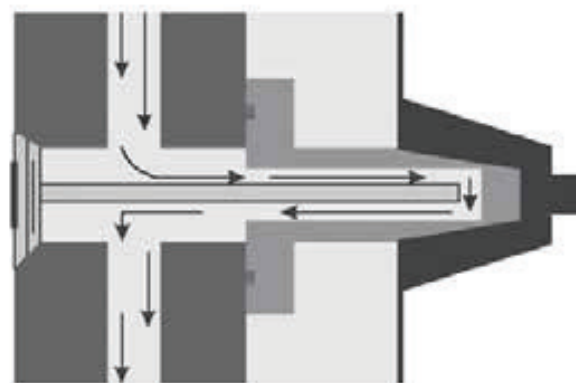

CONVENTIONAL CORE COOLING USING BRASS BAFFLE



[www.acrolab.com](http://www.acrolab.com)

ISOBAR® is a registered trademark of Acrolab Ltd.



# ISOBAR® HEAT PIPES

Custom sizes also available

**ISOBARS® MUST NEVER BE CUT.**

Length Tolerances: +0.000/-0.060 inches

+0.00/-1.50 millimeters

Standard sizes come with extractable end caps

Ordering Information: HP-D X L



DIAMETER	ISOBAR LENGTH (Isobars can also be manufactured to any length and other diameters)																
INCHES	2.0	2.5	3.0	3.5	4.0	4.5	5.0	5.5	6.0	6.5	7.0	7.5	8.0	8.5	9.0	9.5	10.0
3/32																	
1/8																	
5/32																	
3/16																	
7/32																	
1/4																	
5/16																	
3/8																	
1/2																	
MILLIMETERS	50	60	80	100	120	140	160	180	200	220	240	260	280	300	320		
3																	
4																	
5																	
6																	
8																	
10																	
12																	
15																	
16																	
18																	
20																	
25																	
30																	

## ISOBAR® INSTALLATION PROCEDURE

1. Inspect holes into which Isobars will be inserted to make sure that holes are free of oil or solvent contamination, as well as steel chips or other foreign debris.
2. Ensure that hole ends are deburred so as to cause no interference or galling of the Isobar® surface.
3. Apply a liberal amount of thermal paste over the Isobar's® entire length.
4. Apply a small amount of paste into the hole opening and begin to insert the Isobar® by alternately rotating and pushing the Isobar into the hole and withdrawing it slightly to ensure the entire surface of the Isobar® and the hole opening are coated with paste.
5. Insert the Isobars® (threaded end last) with hand pressure only. Never install an Isobar® by tapping, hammering, or using an excessive amount of force, as this will most often result in damage to the Isobars®.
6. Wipe off excess thermal paste from the tool with a soft cloth; do not use solvents.
7. In the event that the holes drilled for the Isobars® are exposed to the outer surface of the mold, these areas must be covered with a 1/8 inch or 3mm steel plate of suitable rigid insulation in order to completely encapsulate the Isobar® within the tooling confines. This should be done as a safety concern to prevent damage resulting from the possible overheating of the tool in excess of 550°F or 280°C.

**CAUTION: EXPOSURE OF ISOBARS® TO EXCESSIVE TEMPERATURES OR IMPROPER USE MAY CAUSE DAMAGE OR PERSONAL INJURY.**

## Thermally Conductive Paste

CATALOG NUMBER	VOLUME
TCP-1	5 GR.
TCP-4	4 OZ.
TCP-8	8 OZ.
TCP-16	16 OZ.

NOTE: Although thermal paste is inert, rubber gloves are recommended to keep hands clean.



www.acrolab.com

ISOBAR® is a registered trademark of Acrolab Ltd.

# HIGH TEMPERATURE INSULATOR SHEETS



Glastherm Grade HT is a high compressive strength, heatresistant composite material. Finished to a close thickness tolerance, it is ideal for installation between the mold and the press or within the mold itself. It is completely asbestos-free and rugged to withstand rough handling during installation.

It is easily cut and machined with standard metal working equipment. Diamond cutting tools are recommended for long life. Compression molded for high impact strength, supplied micro-finished top and bottom, parallel within  $\pm .004$

GENERAL INFORMATION		
		49,400 psi at 75°F
		27,200 psi at 300°F
Compressive Strength	(ASTM D-229)	18,000 psi at 400°F
		17,100 psi at 500°F
		15,000 psi at 550°F
Modules of Elasticity in Compression	(ASTM D-229)	1.8 x 106 psi at 75°F
		2.9 x 106 psi at 75°F
Water Absorption	(ASTM D-229)	0.2%
Thermal Conductivity (K Factor) (Btu/hr/ft <sup>2</sup> /in/°F)	(ASTM C-177)	1.9 at 75°F
		2.1 at 425°F
Flame Resistance	(UL Subject 94)	94V-0
Expansion Across Thickness		6.43 x 10-5 in/in/°F
Expansion Across Surface		6.43 x 10-5 in/in/°F
Maximum Recommended Service Temperature 550°F		

## INSULATOR SHEETS

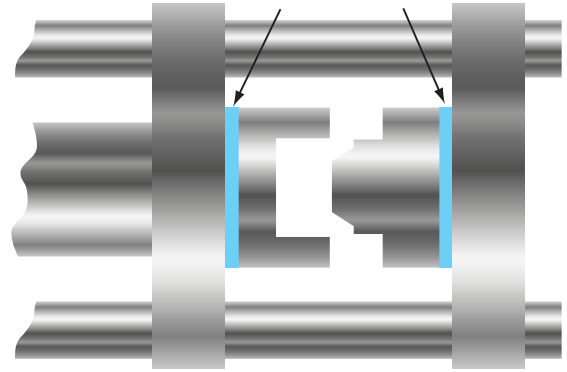

THICKNESS	LENGTH	WIDTH	CATALOG NUMBER
1/4	36"	18"	GTIS1836-25
1/4	36"	24"	GTIS2436-25
1/4	36"	36"	GTIS3636-25
1/2	36"	18"	GTIS1836-50
1/2	36"	24"	GTIS2436-50
1/2	36"	36"	GTIS3636-50
1/4	48"	48"	GTIS4848-25
1/4	48"	96"	GTIS4896-25
1/2	48"	48"	GTIS4848-50
1/2	48"	96"	GTIS4896-50

## STANDARD SERIES

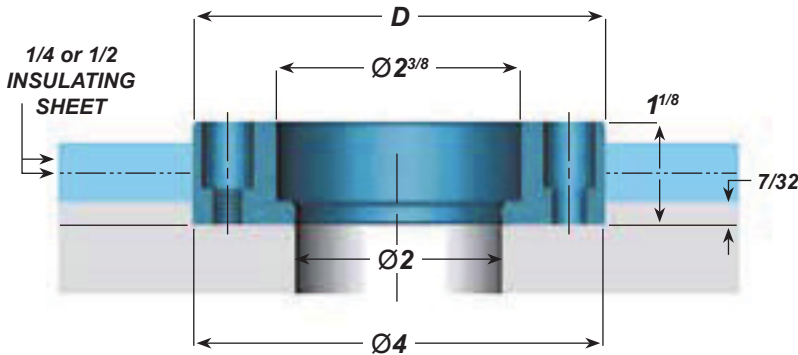

## CLAMP TYPE

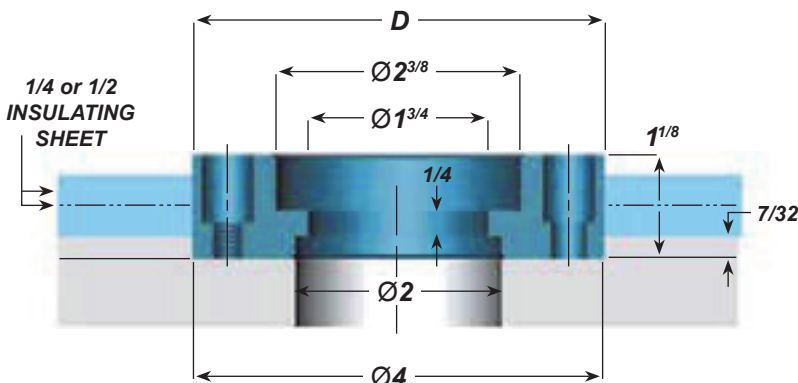

- High hot compressive strength.
- Low thermal conductivity.
- Oil and moisture resistant.
- Reduces heat loss.
- Helps control temperature.
- Faster mold startup.
- Special machining to print available.
- Special sizes also available

## LOCATING RINGS FOR USE WITH INSULATOR SHEETS

CATALOG NUMBER	D	DESCRIPTION
LR541	3.990	Standard Series
LR544	3.990	Clamp Type

GLAS THERM is a registered trademark of Glastic Corp.

# TEMPERATURE CONTROL SYSTEMS



All ITC's temperature control systems, associated components and accessories are ruggedly reliable, easy to use and maintain. Their simple, down-to-earth design makes them highly adaptable in ever changing manufacturing environments. Affordability, adaptability, superior features and a 2-year limited warranty equates to a quick payback, improved molding cycles, less down time, reduced operating costs and an improved bottom line.

## MOLD CABLES

POWER	(AMPS)	LENGTH	THERMOCOUPLE
PWC5-10	(15)	10 ft.	THC5-10
PWC5-20	(15)	20 ft.	THC5-20
PWC8-10	(15)	10 ft.	THC8-10
PWC8-20	(15)	20 ft.	THC8-20
PWC12-10	(15)	10 ft.	THC12-10
PWC12-20	(15)	20 ft.	THC12-20
PWCHP3-10	(30)	10 ft.	
PWCHP3-20	(30)	20 ft.	
PWCHP6-10	(30)	10 ft.	
PWCHP6-20	(30)	20 ft.	

- › Custom lengths and connector configurations are available upon request.



PWC12-10



THC12-10

## PORTABLE FLOOR STANDS

CATALOG NUMBER	USE WITH
PFS-1	MF1, MF2 & MFHP-1
PFS-5	MF5 & MFHP-3
PFS-812	MF8, MF12 & MFHP-6



- › Manufactured of heavy gage steel tubing.
- › Provided with swivel and lockable casters.
- › Shipped unassembled.

## TRANSFORMER PACKAGES

CATALOG NUMBER	STEP DOWN 480v TO 240v 3-PHASE
TP-6-5	6 kva with 5 zone stand
TP-9-8	9 kva with 8 zone stand
TP15-8	15 kva with 8 zone stand
TP15-12	15 kva with 12 zone stand
TP-30-8	30 kva with 8 zone stand
TP-30-12	30 kva with 12 zone stand
TP-45-12	45 kva with 12 zone stand



- › Pre-wired and assembled.
- › Includes Transformer, Welded stand with casters, Fused disconnect and 10 ft. AC input power cable (no connector on end).

## MOLD CONNECTORS

POWER	(AMPS)	THERMOCOUPLE
MPC-5	(15)	MTC-5
MPC-8	(15)	MTC-8
MPC-12	(15)	MTC-12
MPCHP-3	(30)	
MPCHP-6	(30)	

- › Mold Power Connectors have 6' leads with ground wire.



MPC-5



MTC-5

# TEMPERATURE CONTROL SYSTEMS



## 1 & 2 ZONE CONNECTOR KITS (Combination Power & T/C)

CAT. NO.	(AMPS)	DESCRIPTION
1Z-ME	(15)	Cable End, Male Connector, 1 & 2 Zone
1Z-FE	(15)	Cable End, Female Connector, 1 & 2 Zone
1Z-MC	(15)	Mold Connector, Male, 1 & 2 Zone
1Z-FC	(15)	Frame Connector, Female, 1 & 2 Zone
1Z-MEL	(15)	Cable Coupler Hood, w/Latch, Male, 1 & 2 Zone
1Z-ME90	(15)	Cable End, Male Connector, 90°
1Z-IPP	(15)	Input Power Cord Plug (Female)
MPTCHP-1	(30)	Mold Connector, 1 & 2 Zone (Male) (High Power)



## 1 & 2 ZONE CABLES (Combination Power & T/C)

Custom lengths and connector configurations are available upon request.

CAT. NO.	(AMPS)	LENGTH
PTC1-10	(15)	10 ft long
PTC1-20	(15)	20 ft. long
PTCHP1-10	(30)	10 ft. long (High Power)
PTCHP1-20	(30)	20 ft. long (High Power)

## CONNECTOR KITS

CAT. NO.	(AMPS)	DESCRIPTION
MEK-5TC	(15)	Cable, Mold End Kit, 5 Zone, Thermocouple (Female)
MEK-8TC	(15)	Cable, Mold End Kit, 8 Zone, Thermocouple (Female)
MEK-12TC	(15)	Cable, Mold End Kit, 12 Zone, Thermocouple (Female)
MEK-PR	(15)	Cable, Mold End Kit, 5, 8 & 12 Zone, Power (Female)
FEK-PR	(15)	Cable, Frame End Kit, 5, 8 & 12 Zone, Power (Male)
FEK-TC	(15)	Cable, Frame End Kit, 5, 8 & 12 Zone, Thermocouple (Female)
FCK-PR	(15)	Main Frame, Connector, 5, 8 & 12 Zone, Power (Female)
FCK-TC	(15)	Main Frame, Connector, 5, 8 & 12 Zone, Thermocouple (Male)
MF-EC	All	Card Edge Connector Kit w/Contacts - All Main Frames
MF-ECC	All	Card Edge Connector, Contacts - All Main Frames
MF-CG	All	Card Guide, 6" - All Main Frames
ABC-15	All	Module Fuse - Special Fast Blow
MEKHP-3PR	(30)	Cable, Mold End Kit, 3 Zone, Power (Female) (High Power)
MEKHP-6PR	(30)	Cable, Mold End Kit, 6 Zone, Power (Female) (High Power)
FEKHP-3PR	(30)	Cable, Frame End Kit, 3 Zone, Power (Male) (High Power)
FEKHP-6PR	(30)	Cable, Frame End Kit, 6 Zone, Power (Male) (High Power)
FCKHP-3PR	(30)	Main Frame, Connector, 3 Zone, Power (Female) (High Power)
FCKHP-6PR	(30)	Main Frame, Connector, 6 Zone, Power (Female) (High Power)

## MAIN FRAME HARNESES

- Main Frames, Temperature Control Modules, Cables and other components are all sold separately.
- Please specify Voltage and Current requirements when ordering.



MF-TH12



MF-PH12

POWER	ZONES	THERMOCOUPLE
MF-PH5	5	MF-TH5
MF-PH8	8	MF-TH8
MF-PH12	12	MF-TH12

## MOLD WIRING JUNCTION BOXES



### Empty

Connectors must be ordered separately.

CAT. NO.	ZONES
MJB-5	5
MJB-8	8
MJB-12	12

### Pre-Wired

Pre-wired with terminal strip and connectors



CAT. NO.	ZONES
MJBW-8	8
MJBW-12	12

## MAIN FRAME BLANK PANEL

CAT. NO.	FITS
MFBP	ALL 15 & 30 AMP MAIN FRAMES

- Standard Main Frames, Cables, etc. can be modified to accommodate your application.

- All modular components are "G" Series compatible.



# TEMPERATURE CONTROL SYSTEMS

CATALOG NUMBER	DESCRIPTION
VCS-16-16-70	16 - Zone w / 70 amp breaker
VCS-32-18-100	18 - Zone w / 100 amp breaker
VCS-32-20-100	20 - Zone w / 100 amp breaker
VCS-32-22-100	22 - Zone w / 100 amp breaker
VCS-32-24-100	24 - Zone w / 100 amp breaker
VCS-32-26-100	26 - Zone w / 100 amp breaker
VCS-32-28-100	28 - Zone w / 100 amp breaker
VCS-32-30-100	30 - Zone w / 100 amp breaker
VCS-32-32-100	32 - Zone w / 100 amp breaker
VCS-48-34-125	34 - Zone w / 125 amp breaker
VCS-48-36-125	36 - Zone w / 125 amp breaker
VCS-48-38-125	38 - Zone w / 125 amp breaker
VCS-48-40-125	40 - Zone w / 125 amp breaker
VCS-48-42-125	42 - Zone w / 125 amp breaker
VCS-48-44-125	44 - Zone w / 125 amp breaker
VCS-48-46-125	46 - Zone w / 125 amp breaker
VCS-48-48-125	48 - Zone w / 125 amp breaker
VCS-64-50-125	50 - Zone w / 125 amp breaker
VCS-64-52-125	52 - Zone w / 125 amp breaker
VCS-64-54-125	54 - Zone w / 125 amp breaker
VCS-64-56-125	56 - Zone w / 125 amp breaker
VCS-64-58-125	58 - Zone w / 125 amp breaker
VCS-64-60-125	60 - Zone w / 125 amp breaker
VCS-64-62-125	62 - Zone w / 125 amp breaker
VCS-64-64-125	64 - Zone w / 125 amp breaker
VCS-80-66-150	66 - Zone w / 150 amp breaker
VCS-80-68-150	68 - Zone w / 150 amp breaker
VCS-80-70-150	70 - Zone w / 150 amp breaker
VCS-80-72-150	72 - Zone w / 150 amp breaker
VCS-80-74-150	74 - Zone w / 150 amp breaker
VCS-80-76-150	76 - Zone w / 150 amp breaker
VCS-80-78-150	78 - Zone w / 150 amp breaker
VCS-80-80-150	80 - Zone w / 150 amp breaker
VCS-96-82-150	82 - Zone w / 150 amp breaker
VCS-96-84-150	84 - Zone w / 150 amp breaker
VCS-96-86-150	86 - Zone w / 150 amp breaker
VCS-96-88-150	88 - Zone w / 150 amp breaker
VCS-96-90-150	90 - Zone w / 150 amp breaker
VCS-96-92-150	92 - Zone w / 150 amp breaker
VCS-96-94-150	94 - Zone w / 150 amp breaker
VCS-96-96-150	96 - Zone w / 150 amp breaker
VCS-112-98-175	98 - Zone w / 175 amp breaker
VCS-112-100-175	100 - Zone w / 175 amp breaker
VCS-112-102-175	102 - Zone w / 175 amp breaker
VCS-112-104-175	104 - Zone w / 175 amp breaker
VCS-112-106-175	106 - Zone w / 175 amp breaker
VCS-112-108-175	108 - Zone w / 175 amp breaker
VCS-112-110-175	110 - Zone w / 175 amp breaker
VCS-112-112-175	112 - Zone w / 175 amp breaker
VCS-128-114-200	114 - Zone w / 200 amp breaker
VCS-128-116-200	116 - Zone w / 200 amp breaker
VCS-128-118-200	118 - Zone w / 200 amp breaker
VCS-128-120-200	120 - Zone w / 200 amp breaker
VCS-128-122-200	122 - Zone w / 200 amp breaker
VCS-128-124-200	124 - Zone w / 200 amp breaker
VCS-128-126-200	126 - Zone w / 200 amp breaker
VCS-128-128-200	128 - Zone w / 200 amp breaker

## VISIONS 3000 INTELLIGENT TEMPERATURE CONTROL SYSTEM

- ▶ Unless otherwise specified, all VISIONS 3000 systems are 240v, 3-phase.
- ▶ Systems are available for both 15 and 30 amp zones.
- ▶ VISIONS 3000 offered with standard key-pad interface or optional touch screen interface.
- ▶ Valve gate sequencing option.
- ▶ Special or larger control systems, as well as dual or low voltage systems are available upon request.



## STANDARD 15 AMP MAIN FRAME

CATALOG NUMBER	DESCRIPTION
MF1	1 - Zone
MF2	2 - Zone
MF5-150	5 - Zone w / 50 amp breaker
MF8-150	8 - Zone w / 50 amp breaker
MF12-150	12 - Zone w / 50 amp breaker
MF16-250	16 - Zone w / (2) 50 amp breakers
MF16-170	16 - Zone w / 70 amp breaker
MF20-250	20 - Zone w / (2) 50 amp breakers
MF20-170	20 - Zone w / 70 amp breaker
MF24-250	24 - Zone w / (2) 50 amp breakers
MF24-170	24 - Zone w / 70 amp breaker
MF28-350	28 - Zone w / (3) 50 amp breakers
MF32-350	32 - Zone w / (3) 50 amp breakers
MF40-450	40 - Zone w / (4) 50 amp breakers
MF44-450	44 - Zone w / (4) 50 amp breakers
MF48-450	48 - Zone w / (4) 50 amp breakers



- ▶ 15 & 30 amp main frames use S20-D3C & UATC-20 control modules.
- ▶ 240v, 3-phase, except MF1 & MF2 which are 240v single phase.
- ▶ Components contained within the main frame.
- ▶ Special or larger control systems available.
- ▶ Stacks of 2 or more main frames are rigidly fastened together into a single prewired unit.

## STANDARD 30 AMP MAIN FRAME

CATALOG NUMBER	DESCRIPTION
MFHP-1-130	1 - Zone w / 30 amp breaker
MFHP-3-150	3 - Zone w / 50 amp breaker
MFHP-6-1100	6 - Zone w / 100 amp breaker



# INTRODUCING 360° MANIFOLDS

The Kool Flow 360° Inlet design offers more flexibility to have supply and return lines in any direction.

This design also offers the convenience of less plumbing and hardware.

## 360° Port-to-Port (PP)

### Limited for space?

With a port-to-port configuration you can separate Hot & Cold and mount in different locations.

COLOUR	# OF INLETS	# OF OUTLETS	# OF BLOCKS
Red/Silver	One each End	48 Max	10 Max
Blue/Silver	One each End	48 Max	10 Max



## 360° Port-to-Blank (PB)

### No costly end-plug.

With a port-to-blank configuration you can eliminate the costly end plug and still mount the Hot & Cold in different locations.

COLOUR	# OF INLETS	# OF OUTLETS	# OF BLOCKS
Red/Silver	One	49 Max	11 Max
Blue/Silver	One	11 Max	



## 360° Port-to-Divide (PD)

### Combine your cooling needs into one manifold.

Separate Hot & Cold with a Mid-Block and mount in one easy location.

COLOUR	# OF INLETS	# OF OUTLETS	# OF BLOCKS
Red/Silver/Blue	One each End	98 Max	21 Max



# FB2 SERIES MANIFOLD

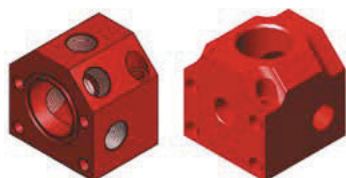

**Port-to-Port (PP)**

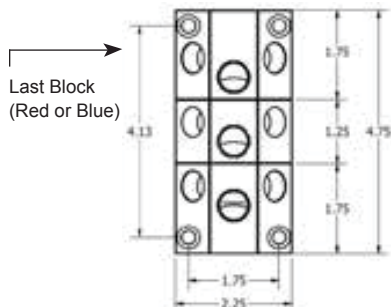

**Port-to-Divide (PD)**

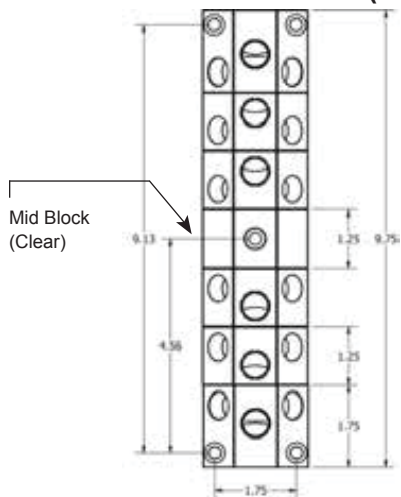

**Port-to-Port**



**1/4" Outlet, Red**  
Assembly No.

FB2-2-4-R-PP  
FB2-3-4-R-PP  
FB2-4-4-R-PP  
FB2-5-4-R-PP

**1/4" Outlet, Blue**  
Assembly No.

FB2-2-4-B-PP  
FB2-3-4-B-PP  
FB2-4-4-B-PP  
FB2-5-4-B-PP

**3/8" Outlet, Red**  
Assembly No.

FB2-2-6-R-PP  
FB2-3-6-R-PP  
FB2-4-6-R-PP  
FB2-5-6-R-PP

**3/8" Outlet, Blue**  
Assembly No.

FB2-2-6-B-PP  
FB2-3-6-B-PP  
FB2-4-6-B-PP  
FB2-5-6-B-PP

## Specifications

Block Size: 2.25" W x 2.25" H  
Material: 6061-T6, Anodized  
Mounting Hole Size: 1/4" SHCS  
Inlet Hole: 1" NPT  
Outlet Hole: 1/4" or 3/8"  
(5) Outlet Holes per Standard Block  
(3) Outlet Holes per 90 Degree Block

## Port-to-Blank (PB)

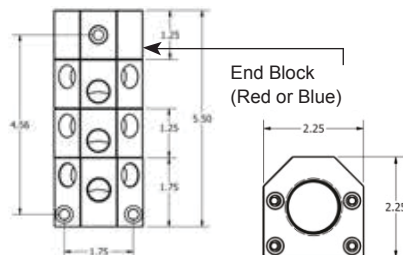

## Port-to-Divide



**1/4" Outlet**  
Assembly No.

FB2-1-4-PD  
FB2-2-4-PD  
FB2-3-4-PD  
FB2-4-4-PD  
FB2-5-4-PD

**3/8" Outlet**  
Assembly No.

FB2-1-6-PD  
FB2-2-6-PD  
FB2-3-6-PD  
FB2-4-6-PD  
FB2-5-6-PD

## Port-to-Blank



**1/4" Outlet, Red**  
Assembly No.

FB2-1-4-R-PB  
FB2-2-4-R-PB  
FB2-3-4-R-PB  
FB2-4-4-R-PB  
FB2-5-4-R-PB

**1/4" Outlet, Blue**  
Assembly No.

FB2-1-4-B-PB  
FB2-2-4-B-PB  
FB2-3-4-B-PB  
FB2-4-4-B-PB  
FB2-5-4-B-PB

**3/8" Outlet, Red**  
Assembly No.

FB2-1-6-R-PB  
FB2-2-6-R-PB  
FB2-3-6-R-PB  
FB2-4-6-R-PB  
FB2-5-6-R-PB

**3/8" Outlet, Blue**  
Assembly No.

FB2-1-6-B-PB  
FB2-2-6-B-PB  
FB2-3-6-B-PB  
FB2-4-6-B-PB  
FB2-5-6-B-PB

## 90 Deg First Block 90 Deg Last Block

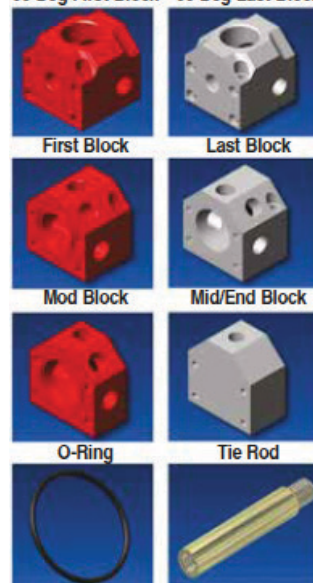

Assembly includes o-rings and hardware required for each block.

## 90 Deg First Block

Part Number	Outlet Size	Color
FB2-FB90-1-4-R	1/4"	Red
FB2-FB90-1-4-B	1/4"	Blue
FB2-FB90-1-6-R	3/8"	Red
FB2-FB90-1-6-B	3/8"	Blue

## 90 Deg Last Block

Part Number	Outlet Size	Color
FB2-FB90-1-4-CL	1/4"	Clear
FB2-FB90-1-6-CL	3/8"	Clear

## First Block

Part Number	Outlet Size	Color
FB2-FB-1-4-R	1/4"	Red
FB2-FB-1-4-B	1/4"	Blue
FB2-FB-1-6-R	3/8"	Red
FB2-FB-1-6-B	3/8"	Blue

## Mod Block

Part Number	Outlet Size	Color
FB2-MOD-4-R	1/4"	Red
FB2-MOD-4-B	1/4"	Blue
FB2-MOD-6-R	3/8"	Red
FB2-MOD-6-B	3/8"	Blue

## Last Block (Port-to-Port only)

Part Number	Outlet Size	Color
FB2-EB-1-CL	n/a	Clear

## Mid/End Block

Part Number	Outlet Size	Color
FB2-LB-1-4-CL	1/4"	Clear
FB2-LB-1-6-CL	3/8"	Clear



# FB2 90° SERIES

## Specifications

Block Size: 2.25" W x 2.25" H  
 Material: 6061-T6, Anodized  
 Mounting Hole Size: 1/4" SHCS  
 Inlet Hole: 1" NPT

## Specifications

Outlet Hole: 1/4" or 3/8"  
 (5) Outlet Holes per Standard Block  
 (3) Outlet Holes per 90 Degree Block

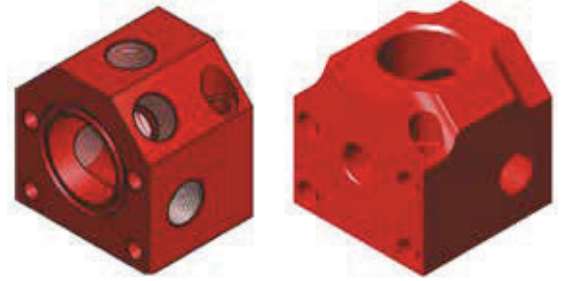

## Port-to-Divide (PD)

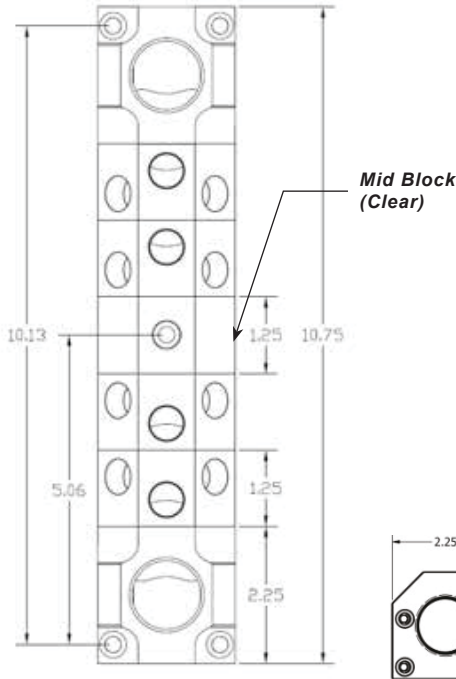

## Port-to-Port (PP)

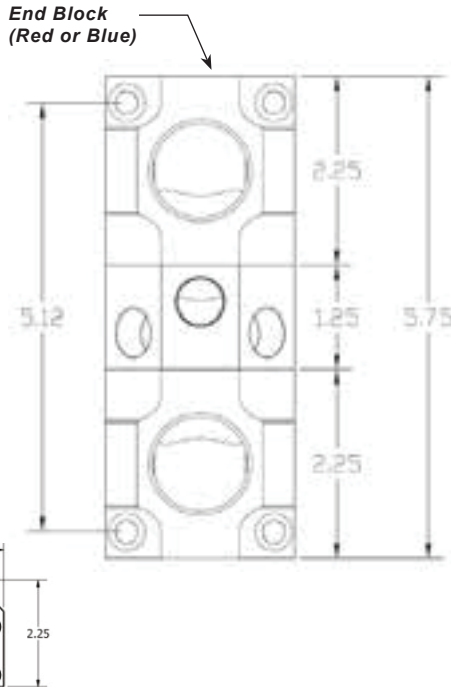

## Port-to-Blank (PB)

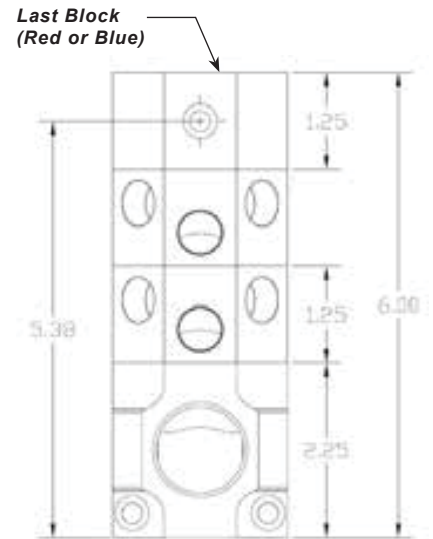

## Port-to-Divide

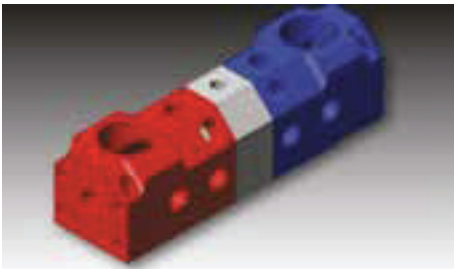

## Port-to-Port



## Port-to-Blank



**1/4" Outlet**  
 Assembly No.

- FB290-1-4-PD
- FB290-2-4-PD
- FB290-3-4-PD
- FB290-4-4-PD
- FB290-5-4-PD

**3/8" Outlet**  
 Assembly No.

- FB290-1-6-PD
- FB290-2-6-PD
- FB290-3-6-PD
- FB290-4-6-PD
- FB290-5-6-PD

**1/4" Outlet, Red**  
 Assembly No.

- FB290-2-4-R-PP
- FB290-3-4-R-PP
- FB290-4-4-R-PP
- FB290-5-4-R-PP

**1/4" Outlet, Blue**  
 Assembly No.

- FB290-2-4-B-PP
- FB290-3-4-B-PP
- FB290-4-4-B-PP
- FB290-5-4-B-PP

**3/8" Outlet, Red**  
 Assembly No.

- FB290-2-6-R-PP
- FB290-3-6-R-PP
- FB290-4-6-R-PP
- FB290-5-6-R-PP

**3/8" Outlet, Blue**  
 Assembly No.

- FB290-2-6-B-PP
- FB290-3-6-B-PP
- FB290-4-6-B-PP
- FB290-5-6-B-PP

**1/4" Outlet, Red**  
 Assembly No.

- FB290-1-4-R-PB
- FB290-2-4-R-PB
- FB290-3-4-R-PB
- FB290-4-4-R-PB
- FB290-5-4-R-PB

**1/4" Outlet, Blue**  
 Assembly No.

- FB290-1-4-B-PB
- FB290-2-4-B-PB
- FB290-3-4-B-PB
- FB290-4-4-B-PB
- FB290-5-4-B-PB

**3/8" Outlet, Red**  
 Assembly No.

- FB290-1-6-R-PB
- FB290-2-6-R-PB
- FB290-3-6-R-PB
- FB290-4-6-R-PB
- FB290-5-6-R-PB

**3/8" Outlet, Blue**  
 Assembly No.

- FB290-1-6-B-PB
- FB290-2-6-B-PB
- FB290-3-6-B-PB
- FB290-4-6-B-PB

# FB3 SERIES MANIFOLD

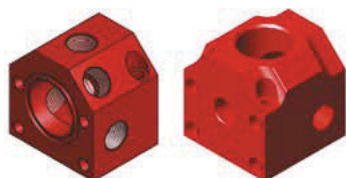

**Port-to-Port (PP)**

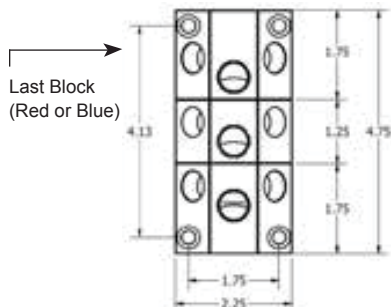

**Port-to-Divide (PD)**

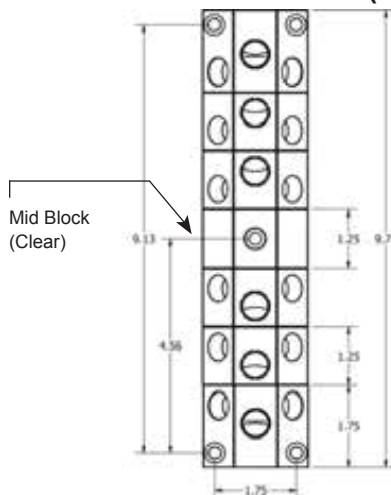

**Port-to-Port**



**3/8" Outlet, Red Assembly No.**

FB3-2-6-R-PP  
FB3-3-6-R-PP  
FB3-4-6-R-PP  
FB3-5-6-R-PP

**3/8" Outlet, Blue Assembly No.**

FB3-2-6-B-PP  
FB3-3-6-B-PP  
FB3-4-6-B-PP  
FB3-5-6-B-PP

**1/2" Outlet, Red Assembly No.**

FB3-2-8-R-PP  
FB3-3-8-R-PP  
FB3-4-8-R-PP  
FB3-5-8-R-PP

**1/2" Outlet, Blue Assembly No.**

FB3-2-8-B-PP  
FB3-3-8-B-PP  
FB3-4-8-B-PP  
FB3-5-8-B-PP

## Specifications

Block Size: 3.00" W x 3.00" H  
Material: 6061-T6, Anodized  
Mounting Hole Size: 3/8" SHCS Inlet  
Hole: 1-1/2" NPT  
Outlet Hole: 3/8" or 1/2"  
(5) Outlet Holes per Standard Block  
(3) Outlet Holes per 90 Degree Block

## Port-to-Blank (PB)

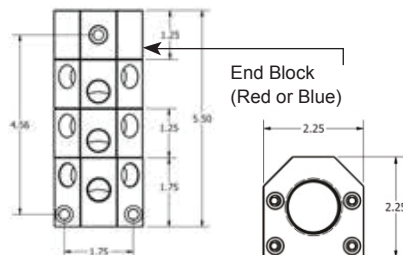

## Port-to-Divide



**3/8" Outlet Assembly No.**

FB3-1-6-PD  
FB3-2-6-PD  
FB3-3-6-PD  
FB3-4-6-PD  
FB3-5-6-PD

**1/2" Outlet Assembly No.**

FB3-1-8-PD  
FB3-2-8-PD  
FB3-3-8-PD  
FB3-4-8-PD  
FB3-5-8-PD

## Port-to-Blank



**3/8" Outlet, Red Assembly No.**

FB3-1-6-R-PB  
FB3-2-6-R-PB  
FB3-3-6-R-PB  
FB3-4-6-R-PB  
FB3-5-6-R-PB

**3/8" Outlet, Blue Assembly No.**

FB3-1-6-B-PB  
FB3-2-6-B-PB  
FB3-3-6-B-PB  
FB3-4-6-B-PB  
FB3-5-6-B-PB

**1/2" Outlet, Red Assembly No.**

FB3-1-8-R-PB  
FB3-2-8-R-PB  
FB3-3-8-R-PB  
FB3-4-8-R-PB  
FB3-5-8-R-PB

**1/2" Outlet, Blue Assembly No.**

FB3-1-8-B-PB  
FB3-2-8-B-PB  
FB3-3-8-B-PB  
FB3-4-8-B-PB  
FB3-5-8-B-PB

## 90 Deg First Block 90 Deg Last Block

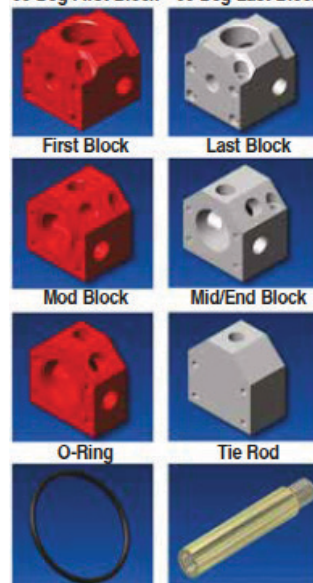

Assembly includes o-rings and hardware required for each block.

## 90 Deg First Block

Part Number	Outlet Size	Color
FB3-FB90-1.5-6-R	3/8"	Red
FB3-FB90-1.5-6-B	3/8"	Blue
FB3-FB90-1.5-8-R	1/2"	Red
FB3-FB90-1.5-8-B	1/2"	Blue

## 90 Deg Last Block

Part Number	Outlet Size	Color
FB3-FB90-1.5-6-CL	3/8"	Clear
FB3-FB90-1.5-8-CL	1/2"	Clear

## First Block

Part Number	Outlet Size	Color
FB3-FB-1.5-6-R	3/8"	Red
FB3-FB-1.5-6-B	3/8"	Blue
FB3-FB-1.5-8-R	1/2"	Red
FB3-FB-1.5-8-B	1/2"	Blue

## Mod Block

Part Number	Outlet Size	Color
FB3-MOD-6-R	3/8"	Red
FB3-MOD-6-B	3/8"	Blue
FB3-MOD-8-R	1/2"	Red
FB3-MOD-8-B	1/2"	Blue

## Last Block (Port-to-Port only)

Part Number	Outlet Size	Color
FB3-LB-1.5-6-CL	3/8"	Clear
FB3-LB-1.5-8-CL	1/2"	Clear

## Mid/End Block

Part Number	Outlet Size	Color
FB3-EB-1.5-CL	n/a	Clear



# FB3 90° SERIES

## Specifications

Block Size: 3.00" W × 3.00" H

Material: 6061-T6, Anodized

Mounting Hole Size: 5/6" SHCS

Inlet Hole: 1-1/2" NPT

Outlet Hole: 3/8" or 1/2"

(5) Outlet Holes per Standard Block

(3) Outlet Holes per 90° Block

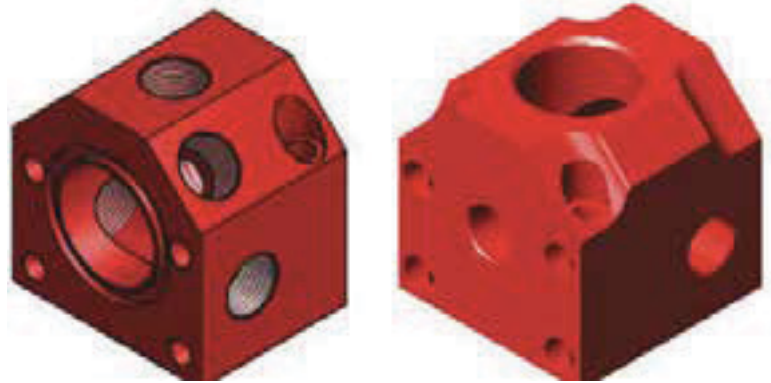

## Port-to-Divide FB390-2-6-PD



## Port-to-Port FB390-3-6-R-PP



## Port-to-Blank FB390-2-6-R-PB



**3/8" Outlet**  
Assembly No.

**1/2" Outlet**  
Assembly No.

FB390-1-6-PD

FB390-1-8-PD

FB390-2-6-PD

FB390-2-8-PD

FB390-3-6-PD

FB390-3-8-PD

FB390-4-6-PD

FB390-4-8-PD

FB390-5-6-PD

FB390-5-8-PD

**3/8" Outlet, Red**  
Assembly No.

**1/2" Outlet, Red**  
Assembly No.

FB390-2-6-R-PP

FB390-2-8-R-PP

FB390-3-6-R-PP

FB390-3-8-R-PP

FB390-4-6-R-PP

FB390-4-8-R-PP

FB390-5-6-R-PP

FB390-5-8-R-PP

**3/8" Outlet, Blue**  
Assembly No.

**1/2" Outlet, Blue**  
Assembly No.

FB390-2-6-B-PP

FB390-2-8-B-PP

FB390-3-6-B-PP

FB390-3-8-B-PP

FB390-4-6-B-PP

FB390-4-8-B-PP

FB390-5-6-B-PP

FB390-5-8-B-PP

**3/8" Outlet, Red**  
Assembly No.

**1/2" Outlet, Red**  
Assembly No.

FB390-1-6-R-PB

FB390-1-8-R-PB

FB390-2-6-R-PB

FB390-2-8-R-PB

FB390-3-6-R-PB

FB390-3-8-R-PB

FB390-4-6-R-PB

FB390-4-8-R-PB

FB390-5-6-R-PB

FB390-5-8-R-PB

**3/8" Outlet, Blue**  
Assembly No.

**1/2" Outlet, Blue**  
Assembly No.

FB390-1-6-B-PB

FB390-1-8-B-PB

FB390-2-6-B-PB

FB390-2-8-B-PB

FB390-3-6-B-PB

FB390-3-8-B-PB

FB390-4-6-B-PB

FB390-4-8-B-PB

FB390-5-6-B-PB

FB390-5-8-B-PB

# SPECIALS

- > DMS can offer a wide range of heating and cooling products that may not be shown in this catalog.
- > As a full service manufacturer and supplier, we can provide design assistance and prototype or production quantities of special heating and cooling products.
- > The items on this page represent just a few of the many specials that have been manufactured for unique applications.



## Special and Large Pipe Fittings



## Metric and Special Adapters

DMS Pipe Check is an easy way to check a pipe thread. This handy tool can check pipe sizes from 1/16" through 1/2" for a number of applications. Use the PC-100 to quickly find the size of a pipe.

## Pipe Thread Data

The nominal size of any pipe does not in fact refer to either the outside diameter (O.D.) or the inside diameter (I.D.) of the pipe. The table lists standard pipe sizes along with the actual O.D. and I.D. for each size.

Once the correct pipe size has been determined, the "E" dimension may be used to determine the length of the component required to assemble properly when fully tightened.

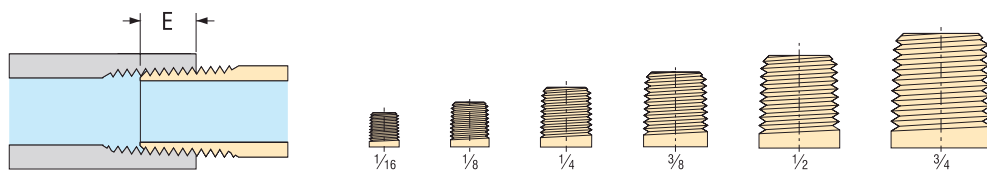

## PIPE CHECK

### PC-100

PC-100 simply determines the size of pipes from 1/16" to 1/2" NPT. Made entirely of heavy gauge aluminum. Just turn the thread into the hole that fits to determine pipe sizes.



PIPE SIZE	THREADS PER INCH	OUTSIDE DIA. OF PIPE	INSIDE DIA. OF PIPE	TAP DRI WITHOUT REAM	LL SIZE WITH REAM	E
1/16	27	0.312	0.209	1/4	15/64	0.261
1/8	27	0.405	0.269	11/32	21/64	0.263
1/4	18	0.540	0.364	7/16	27/64	0.395
3/8	18	0.675	0.493	9/16	9/16	0.407
1/2	14	0.840	0.622	45/64	11/16	0.534
3/4	14	1.050	0.824	29/32	57/64	0.545
1"	11-1/2	1.315	1.049	1-9/64	1-1/8	0.661
1-1/4	11-1/2	1.660	1.380	1-31/64	1-15/32	0.681
1-1/2	11-1/2	1.900	1.610	1-23/32	1-45/64	0.681
2"	11-1/2	2.375	2.067	2-3/16	2-11/64	0.697

# INLINE ALUMINUM MANIFOLDS

- > Standard Blue and Red
- > Divided
- > Made to Cito Foot Print
- > 1-1/4" and 1-1/2" Inlet
- > 3/8 and 1/2" Outlet holes
- > Anodized Aluminum
- > Also available without colour

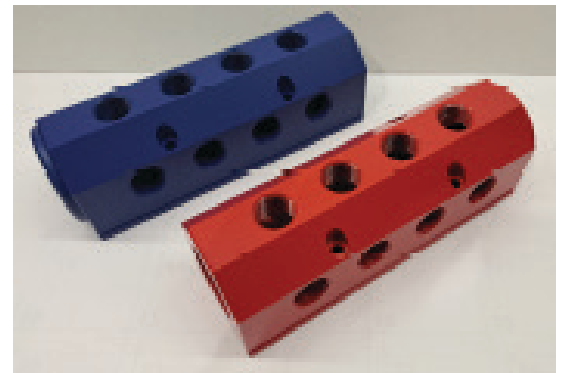

## Metric and Special Adapters

Part #	Type	Inlet NPT	Outlet NPT	# of Outlets	Slides	Length	Color
IM58ACE1212N*	STD	1-1/4"	1/2"	12	ACE	7.5"	Blue or Red
IM511ACE1812N*	STD	1-1/4"	1/2"	18	ACE	10.5"	Blue or Red
IM514ACE2412*	STD	1-1/4"	1/2"	24	ACE	13.5"	Blue or Red
IM66ABCDE1012N*	STD	1-1/2"	1/2"	10	ABCDE	6	Blue or Red
IM610ABCDE2012N*	STD	1-1/2"	1/2"	20	ABCDE	10	Blue or Red
IM614ABCDE3012N*	STD	1-1/2"	1/2"	30	ABCDE	14	Blue or Red

\*= "B" Blue or "R" Red

More options and sizes available upon request.  
 \*\*\*\*Customized inventory programs available upon request.\*\*\*\*

(519) 737-6743 | [www.dmscomponents.com](http://www.dmscomponents.com) | [sales@dmscomponents.com](mailto:sales@dmscomponents.com)