

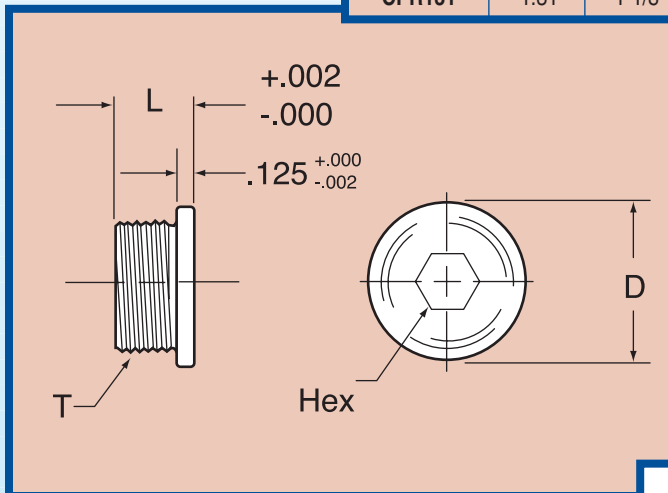

# Core Pin Retainers



Catalog Number	D O.D. -.000 -.010	T Thread	Head Thickness -.002	L Length +.002 -.000	Hex Size	Recommended Pin Sizes
CPR56	.56	3/8 - 24	.125	.437	3/16	3/32 thru 5/32 diameters
CPR68	.68	1/2 - 20	.125	.437	1/4	11/64 thru 9/32 diameters
CPR93	.93	3/4 - 16	.125	.437	3/8	5/16 thru 7/16 diameters
CPR106	1.06	7/8 - 14	.125	.437	3/8	15/32 thru 9/16 diameters
CPR131	1.31	1-1/8 - 12	.125	.437	3/8	5/8 thru 3/4 diameters



Material : 12L14: Black oxidized

- Allows for improved and more consistent installation and removal of core pins by toolmaker
- Does not force the head of the core pin head against the bottom of the counterbore

